



MICROENER

S24/LD (V4) configuration description



FDE 23AA3401021 - Rev. A

Update Management

Rev.	Description	Date	Written by	Checked by	Approved by
Z	Création doc	06/12/2023	AA	LA	LA
A	Diffusion	22/01/2024	AA	LA	LA

CONTENTS

S24/LD relay overview	5
Configuration description	6
Protection functions.....	6
Measurement functions.....	7
Hardware configuration.....	8
Meeting the device	10
Software configuration	11
Protection and control functions	11
Three-phase instantaneous overcurrent protection function (IOC50)	12
Three-phase time overcurrent protection function (TOC51)	13
Residual instantaneous overcurrent protection function (IOC50N).....	16
Residual overcurrent protection function (TOC51N)	17
Negative sequence overcurrent protection function (TOC46)	20
Line differential protection function (DIF87L)	23
Line thermal protection function (TTR49L).....	25
Inrush detection function (INR68).....	28
Auto-reclose protection (REC79MV).....	30
Current unbalance function (VCB60)	33
Breaker failure protection function (BRF50MV)	35
Trip logic (TRC94)	37
Current input function (CT4)	38
Circuit breaker control function block (CB1Pol).....	41
Disconnecter control function (DisConn).....	44
Measuring functions	46
Current input function (CT4).....	47
Disturbance recorder	50
TRIP contact assignment	52
LED assignment.....	54
External connection.....	55
Hardware specification	56
System design	56
CPU module.....	56
Human-Machine Interface (HMI) module	58
Detailed modules description	60
General data	61
Mechanical data	62
Mounting methods of IED EP+S24	62

S24/LD RELAY OVERVIEW

The **S24/LD** series is member of the *Smartline* product line. The **Smartline** complex protection in respect of hardware and software is a modular device. The modules are assembled and configured according to the requirements, and then the software determines the functions. The S24 series is contain a special selection of the PROTECTA modules, bearing in mind the cost effective realization.

The IEDs support a range of communication protocols including the IEC 61850 substation automation standard with horizontal GOOSE communication, IEC 60870-5-101, IEC 60870-5-103 and Modbus® RTU. The IED-EP+ S24 is available in six predefined standard configurations to suit the most common feeder protection and control applications.

The relay is provided with a built-in digital disturbance recorder for up to eight analog signal channels and 32 digital signal channels. The recordings are stored in a non-volatile memory from which data can be uploaded for subsequent fault analysis.

To provide network control and monitoring systems with feeder level event logs, the relay incorporates a non-volatile memory with capacity of storing 1000 event codes including time stamps. The non-volatile memory retains its data also in case the relay temporarily loses its auxiliary supply. The event log facilitates detailed pre- and post-fault analyses of feeder faults and distribution disturbances.

The trip circuit supervision continuously monitors the availability and operability of the trip circuit. It provides open circuit monitoring both when the circuit breaker is in its closed and in its open position.

The relay's built-in self-supervision system continuously monitors the state of the relay hardware and the operation of the relay software. Any fault or malfunction detected will be used for alerting the operator. When a permanent relay fault is detected the protection functions of the relay will be completely blocked to prevent any incorrect relay operation.

CONFIGURATION DESCRIPTION

The **S24/LD (V4)** configuration has included the line differential protection function for medium voltage distribution network.

This chapter describes the specific application of the **S24/LD (V4)** factory configuration.

Protection functions

The **S24/LD (V4)** configuration measures three phase currents, the zero sequence current component.

The main protection functions in this application: is the line differential protection function. The communication hardware module sends and receives phase current vectors to realize this function. The configuration is designed to meet the requirements of a medium voltage field unit, if also line differential protection function is needed. The choice of the functions is extended with the automatic reclosing function.

The configured protection functions are listed in the Table below.

Protection functions	IEC	ANSI	S24/LD (V4)
Three-phase instantaneous overcurrent protection	$I >>>$	50	X
Three-phase time overcurrent protection	$I >, I >>$	51	X
Residual instantaneous overcurrent protection	$I_0 >>>$	50N	X
Residual time overcurrent protection	$I_0 >, I_0 >>$	51N	X
Line differential	$3I_{dL} >$	87L	X
Inrush detection	$I_{2h} >$	68	X
Negative sequence overcurrent protection	$I_2 >$	46	X
Thermal protection	$T >$	49	X
Auto-reclose	$0 - > 1$	79	X
Current unbalance protection		60	X
Breaker failure protection	CBFP	50BF	X

Table 1 The protection functions of the S24/LD (V4) configuration

The configured functions are drawn symbolically in the Figure below.

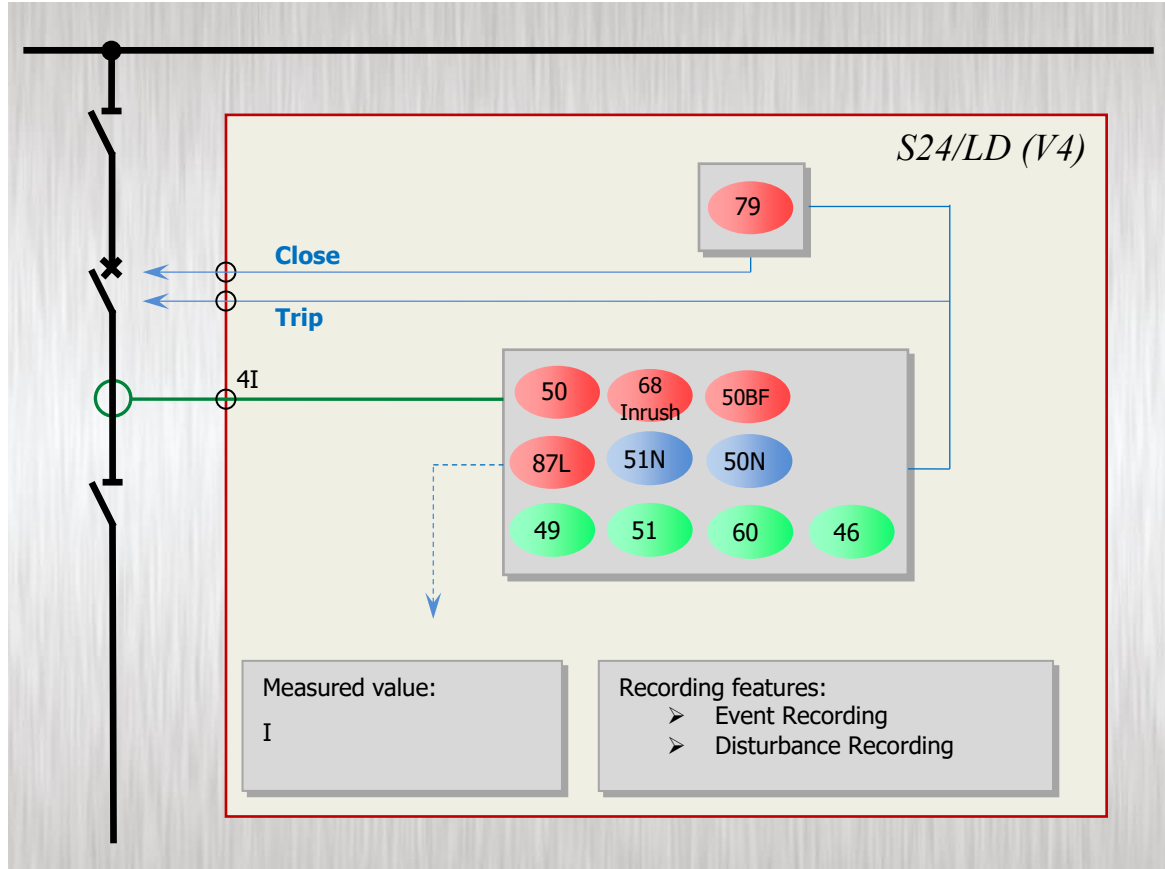

Measurement functions

Based on the hardware inputs the measurements listed in Table below are available.

Measurement functions	S24/LD (V4)
Current (I1, I2, I3, Io)	X
Circuit breaker wear	X
Supervised trip contacts (TCS)	X

Table 2 The measurement functions of the S24/LD (V4) configuration

Hardware configuration

The minimum number of inputs and outputs are listed in the Table below.

Hardware configuration	S24/LD (V4)
Housing	Panel instrument enclosure (24 HP size)
Current inputs (4th channel can be sensitive)	4 (3x 1/5 A and 1x 1/5,0,2A)
Digital inputs	6*
Digital outputs	5*
Fast trip outputs	2 (4 A)
IRF contact	1

* as standard I/O card hardware configuration.

Table 3 The basic hardware configuration of the S24/LD (V4) configuration

IP ratings:

- IP20 protection from rear side
- IP54 protection from front side

Table 4 The basic hardware configuration of the S24/LD (V4) configuration

The basic module arrangement of the S24/LD (V4) configuration is shown below.

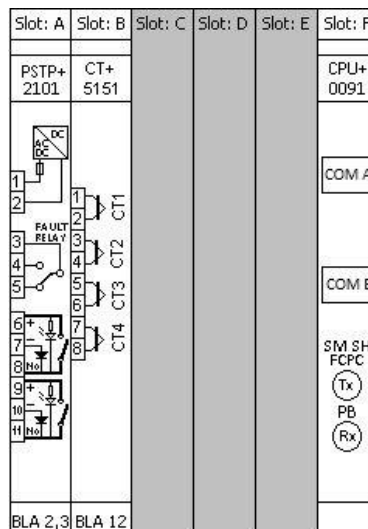

I/O card options for Var 4:

IO card type	SlotC	Slot D	Slot E
O6R5	-	Standard	N/A
O12	-	Option	Option
O8	-	Option	Option
R8	-	Option	Option

Figure 2 Basic module arrangement of the S24/LD (V4) configuration (rear view)

 info@microener.com +33(0)1 48 15 09 09	S24/LD (V4) Configuration description	FDE N°: 23AA3401021
		Rev. : A Page 9 sur 67

Communication options for S24/LD (V4):

Communication ports		No communication	Legacy protocols	IEC 61850	Redundant Ethernet
COM A		Standard	N/A	N/A	Option
COM B		Standard	Option	Option	N/A

The applied hardware modules

The applied modules are listed in Table 5.

The technical specification of the device and that of the modules are described in the document "**Hardware description**".

Module identifier	Explanation
PSTP+ xx01	Power supply unit with trip contacts
O6R5+ xx01	Binary I/O module
O12+ xx01	Binary input module
O8+ xx01	Binary input module
R8+ 00	Signal relay output module
CT+ 5151	Analog current input module
CPU+ xxxx	Processing and communication module

Table 5 The applied modules of the S24/LD (V4) configuration

Meeting the device

The basic information for working with the *Smartline* devices are described in the document "*Quick start guide to the devices of the PROTECTA product line*".

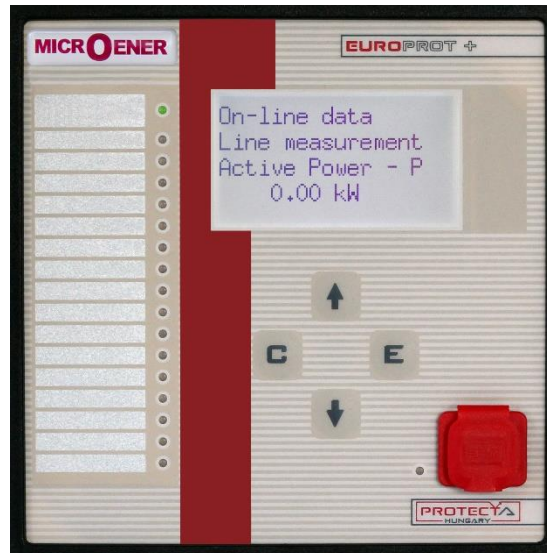

Figure 3 IED EP+ S24 with B&W HMI front panel as standard



Figure 4 IED EP+S24 with true colour HMI front panel as optional

SOFTWARE CONFIGURATION**Protection and control functions**

The implemented protection and control functions are listed in **Erreur ! Source du renvoi introuvable..** The function blocks are described in details in separate documents. These are referred to also in this table.

The range of the parameter settings of the following function blocks can be modified, if it doesn't correspond to the customer's request. In this case please, contact to the developer team on the Microener Support Site: www.microener.com

Name	Title	Document
IOC50	3ph Instant.OC	<i>Three-phase instantaneous overcurrent protection function block description</i>
TOC51_low TOC51_high	3ph Overcurr	<i>Three-phase overcurrent protection function block description</i>
IOC50N	Residual Instant.OC	<i>Residual instantaneous overcurrent protection function block description</i>
TOC51N_low TOC51N_high	Residual TOC	<i>Residual overcurrent protection function block description</i>
TOC46	Neg. Seq. OC	<i>Negative sequence overcurrent protection function block description</i>
DIF87L	Line differential	<i>Line differential protection function block description</i>
INR68	Inrush	<i>Inrush detection and blocking</i>
TTR49L	Thermal overload	<i>Line thermal protection function block description</i>
REC79MV	MV autoreclosing	<i>Automatic reclosing function for medium voltage networks, function block description</i>
VCB60	Current Unbalance	<i>Current unbalance function block description</i>
BRF50MV	Breaker failure	<i>Breaker failure protection for not solidly grounded networks function block description</i>
TRC94	Trip Logic	<i>Trip logic function block description</i>
CT4		<i>Current input function block description</i>
CB1Pol*		<i>Circuit breaker control function block description</i>
DisConn*		<i>Disconnecter control function block description</i>

* The true color HMI is required to use the control functions

Table 1 Implemented protection and control functions

Three-phase instantaneous overcurrent protection function (IOC50)

The three-phase instantaneous overcurrent protection function (IOC50) operates immediately if the phase currents are higher than the setting value.

The setting value is a parameter, and it can be doubled by graphic programming of the dedicated input binary signal defined by the user.

The function is based on peak value selection or on the RMS values of the Fourier basic harmonic calculation, according to the parameter setting. The fundamental Fourier components are results of an external function block.

Parameter for type selection has selection range of Off, Peak value and Fundamental value. When Fourier calculation is selected then the accuracy of the operation is high, the operation time however is above one period of the network frequency. If the operation is based on peak values then fast sub-cycle operation can be expected, but the transient overreach can be high.

The function generates trip commands without additional time delay if the detected values are above the current setting value.

The function generates trip commands for the three phases individually and a general trip command as well.

The instantaneous overcurrent protection function has a binary input signal, which serves the purpose of disabling the function. The conditions of disabling are defined by the user, applying the graphic equation editor.

Technical data

Function		Accuracy
Using peak value calculation		
Operating characteristic	Instantaneous	<6%
Reset ratio	0.85	
Operate time at 2*I _S	<15 ms	
Reset time *	< 40 ms	
Transient overreach	90 %	
Using Fourier basic harmonic calculation		
Operating characteristic	Instantaneous	<2%
Reset ratio	0.85	
Operate time at 2* I _S	<25 ms	
Reset time *	< 60 ms	
Transient overreach	15 %	

**Measured with signal contacts*

Table 2 Technical data of the instantaneous overcurrent protection function

Parameters

Enumerated parameter

Parameter name	Title	Selection range	Default
Parameter for type selection			
IOC50_Oper_EPar_	Operation	Off, Peak value, Fundamental value	Peak value

Table 3 The enumerated parameter of the instantaneous overcurrent protection function

Integer parameter

Parameter name	Title	Unit	Min	Max	Step	Default
Starting current parameter:						
IOC50_StCurr_IPar_	Start Current	%	20	3000	1	200

Table 4 The integer parameter of the instantaneous overcurrent protection function

Three-phase time overcurrent protection function (TOC51)

The overcurrent protection function realizes definite time or inverse time characteristics according to IEC or IEEE standards, based on three phase currents. The characteristics are harmonized with IEC 60255-151, Edition 1.0, 2009-08. This function can be applied as main protection for medium-voltage applications or backup or overload protection for high-voltage network elements.

The definite (independent) time characteristic has a fixed time delay when the current is above the starting current I_s previously set as a parameter.

The standard operating characteristics of the inverse time overcurrent protection function are defined by the following formula:

$$t(G) = TMS \left[\frac{k}{\left(\frac{G}{G_s}\right)^\alpha - 1} + c \right] \text{ when } G > G_s$$

where

t(G)(seconds)

k, c

α

G

G_s

TMS

theoretical operate time with constant value of G,
constants characterizing the selected curve (in seconds),
constants characterizing the selected curve (no dimension),
measured value of the characteristic quantity, Fourier base harmonic of the phase currents (IL1Four, IL2Four, IL3Four),
preset value of the characteristic quantity (Start current),
preset time multiplier (no dimension).

	IEC ref	Title	k_r	c	α
1	A	IEC Inv	0,14	0	0,02
2	B	IEC VeryInv	13,5	0	1
3	C	IEC ExtInv	80	0	2
4		IEC LongInv	120	0	1
5		ANSI Inv	0,0086	0,0185	0,02
6	D	ANSI ModInv	0,0515	0,1140	0,02
7	E	ANSI VeryInv	19,61	0,491	2
8	F	ANSI ExtInv	28,2	0,1217	2
9		ANSI LongInv	0,086	0,185	0,02
10		ANSI LongVeryInv	28,55	0,712	2
11		ANSI LongExtInv	64,07	0,250	2

The end of the effective range of the dependent time characteristics (G_D) is:

$$G_D = 20 * G_s$$

Above this value the theoretical operating time is definite:

$$t(G) = TMS \left[\frac{k}{\left(\frac{G_D}{G_s}\right)^\alpha - 1} + c \right] \text{ when } G > G_D = 20 * G_s$$

Additionally a minimum time delay can be defined by a dedicated parameter. This delay is valid if it is longer than t(G), defined by the formula above.

Resetting characteristics:

- for IEC type characteristics the resetting is after a fix time delay defined by TOC51_Reset_TPar_ (Reset delay),
- for ANSI types however according to the formula below:

$$t_r(G) = TMS \left[\frac{k_r}{1 - \left(\frac{G}{G_s}\right)^\alpha} \right] \text{ when } G < G_s$$

where

$t_r(G)$ (seconds)

k_r

α

G

G_s

TMS

theoretical reset time with constant value of G ,
constants characterizing the selected curve (in seconds),
constants characterizing the selected curve (no dimension),
measured value of the characteristic quantity, Fourier base harmonic of the phase currents,
preset value of the characteristic quantity (Start current),
preset time multiplier (no dimension).

	IEC ref	Title	k_r	α
1	A	IEC Inv	Resetting after fix time delay, according to preset parameter TOC51_Reset_TPar_ "Reset delay"	
2	B	IEC VeryInv		
3	C	IEC ExtInv		
4		IEC LongInv		
5		ANSI Inv	0,46	2
6	D	ANSI ModInv	4,85	2
7	E	ANSI VeryInv	21,6	2
8	F	ANSI ExtInv	29,1	2
9		ANSI LongInv	4,6	2
10		ANSI LongVeryInv	13,46	2
11		ANSI LongExtInv	30	2

The binary output status signals of the three-phase overcurrent protection function are starting signals of the three phases individually, a general starting signal and a general trip command.

The overcurrent protection function has a binary input signal, which serves the purpose of disabling the function. The conditions of disabling are defined by the user, applying the graphic equation editor.

Technical data

Function	Value	Accuracy
Operating accuracy	$20 \leq G_s \leq 1000$	< 2 %
Operate time accuracy		±5% or ±15 ms, whichever is greater
Reset ratio	0,95	
Reset time * Dependent time char. Definite time char.	Approx 60 ms	< 2% or ±35 ms, whichever is greater
Transient overreach		< 2 %
Pickup time *	< 40 ms	
Overshot time Dependent time char. Definite time char.	30 ms 50 ms	
Influence of time varying value of the input current (IEC 60255-151)		< 4 %

* Measured with signal relay contact

Table 5 Technical data of of the instantaneous overcurrent protection function

Parameters

Enumerated parameters

Parameter name	Title	Selection range	Default
Parameter for type selection			
TOC51_Oper_EPar_	Operation	Off, DefinitTime, IEC Inv, IEC VeryInv, IEC ExtInv, IEC LongInv, ANSI Inv, ANSI ModInv, ANSI VeryInv, ANSI ExtInv, ANSI LongInv, ANSI LongVeryInv, ANSI LongExtInv	Definit Time

Table 6 The enumerated parameters of the time overcurrent protection function

Integer parameter

Parameter name	Title	Unit	Min	Max	Step	Default
Starting current parameter:						
TOC51_StCurr_IPar_	Start Current	%	20	1000	1	200

Table 7 The integer parameter of the time overcurrent protection function

Float point parameter

Parameter name	Title	Unit	Min	Max	Step	Default
Time multiplier of the inverse characteristics (OC module)						
TOC51_Multip_FPar_	Time Multiplier	sec	0.05	999	0.01	1.0

Table 8 The float point parameter of the time overcurrent protection function

Timer parameters

Parameter name	Title	Unit	Min	Max	Step	Default
Minimal time delay for the inverse characteristics:						
TOC51_MinDel_TPar_	Min Time Delay *	msec	0	60000	1	100
Definite time delay:						
TOC51_DefDel_TPar_	Definite Time Delay **	msec	0	60000	1	100
Reset time delay for the inverse characteristics:						
TOC51_Reset_TPar_	Reset Time*	msec	0	60000	1	100

*Valid for inverse type characteristics

**Valid for definite type characteristics only

Table 9 The timer parameters of the time overcurrent protection function

Residual instantaneous overcurrent protection function (IOC50N)

The residual instantaneous overcurrent protection function (IOC50N) block operates immediately if the residual current (3I_o) is above the setting value. The setting value is a parameter, and it can be doubled by a dedicated binary input signal defined by the user applying the graphic programming.

The function is based on peak value selection or on the RMS values of the Fourier basic harmonic component of the residual current, according to the parameter setting. The fundamental Fourier component calculation is not part of the IOC50N function.

Parameter for type selection has selection range of Off, Peak value and Fundamental value.

The function generates a trip command without additional time delay if the detected values are above the current setting value.

The residual instantaneous overcurrent protection function has a binary input signal, which serves the purpose of disabling the function. The conditions of disabling are defined by the user, applying the graphic equation editor.

Technical data

Function		Accuracy
Using peak value calculation		
Operating characteristic (I>0.1 In)	Instantaneous	<6%
Reset ratio	0.85	
Operate time at 2*I _S	<15 ms	
Reset time *	< 35 ms	
Transient overreach	85 %	
Using Fourier basic harmonic calculation		
Operating characteristic (I>0.1 In)	Instantaneous	<3%
Reset ratio	0.85	
Operate time at 2*I _S	<25 ms	
Reset time *	< 60 ms	
Transient overreach	15 %	

**Measured with signal contacts*

Table 10 Technical data of the residual instantaneous overcurrent protection function

Parameters

Enumerated parameter

Parameter name	Title	Selection range	Default
Parameter for type selection			
IOC50N_Oper_EPar_	Operation	Off, Peak value, Fundamental value	Peak value

Table 11 The enumerated parameter of the residual instantaneous overcurrent protection function

Integer parameter

Parameter name	Title	Unit	Min	Max	Step	Default
Starting current parameter:						
IOC50N_StCurr_IPar_	Start Current	%	10	400	1	200

Table 12 The integer parameter of the residual instantaneous overcurrent protection function

Residual overcurrent protection function (TOC51N)

The residual delayed overcurrent protection function can realize definite time or inverse time characteristics according to IEC or IEEE standards, based on the RMS value of the fundamental Fourier component of a single measured current, which can be the measured residual current at the neutral point (3Io) or the calculated zero sequence current component. The characteristics are harmonized with IEC 60255-151, Edition 1.0, 2009-08.

The definite (independent) time characteristic has a fixed time delay when the current is above the starting current I_s previously set as a parameter.

The standard operating characteristics of the inverse time overcurrent protection function are defined by the following formula:

$$t(G) = TMS \left[\frac{k}{\left(\frac{G}{G_s}\right)^\alpha - 1} + c \right] \text{ when } G > G_s$$

where

t(G)(seconds)

k, c

α

G

G_s

TMS

theoretical operate time with constant value of G,

constants characterizing the selected curve (in seconds),

constant characterizing the selected curve (no dimension),

measured value of the characteristic quantity, Fourier base harmonic of the residual current (INFour),

preset value of the characteristic quantity (Start current),

preset time multiplier (no dimension).

	IEC ref		k_r	c	α
1	A	IEC Inv	0,14	0	0,02
2	B	IEC VeryInv	13,5	0	1
3	C	IEC ExtInv	80	0	2
4		IEC LongInv	120	0	1
5		ANSI Inv	0,0086	0,0185	0,02
6	D	ANSI ModInv	0,0515	0,1140	0,02
7	E	ANSI VeryInv	19,61	0,491	2
8	F	ANSI ExtInv	28,2	0,1217	2
9		ANSI LongInv	0,086	0,185	0,02
10		ANSI LongVeryInv	28,55	0,712	2
11		ANSI LongExtInv	64,07	0,250	2

The end of the effective range of the dependent time characteristics (G_D) is:

$$G_D = 20 * G_s$$

Above this value the theoretical operating time is definite:

$$t(G) = TMS \left[\frac{k}{\left(\frac{G_D}{G_s}\right)^\alpha - 1} + c \right] \text{ when } G > G_D = 20 * G_s$$

Additionally a minimum time delay can be defined by a dedicated parameter (Min. Time Delay). This delay is valid if it is longer than t(G), defined by the formula above.

Resetting characteristics:

- for IEC type characteristics the resetting is after a fix time delay,
- for ANSI types however according to the formula below:

$$t_r(G) = TMS \left[\frac{k_r}{1 - \left(\frac{G}{G_S} \right)^\alpha} \right] \text{ when } G < G_S$$

where

$t_r(G)$ (seconds)

k_r

α

G

G_S

TMS

theoretical reset time with constant value of G ,

constants characterizing the selected curve (in seconds),

constant characterizing the selected curve (no dimension),

measured value of the characteristic quantity, Fourier base harmonic of the residual current,

preset value of the characteristic quantity (Start current),

preset time multiplier (no dimension).

	IEC ref		k_r	α
1	A	IEC Inv	Resetting after fix time delay, according to preset parameter TOC51_Reset_TPar_ "Reset delay"	
2	B	IEC VeryInv		
3	C	IEC ExtInv		
4		IEC LongInv		
5		ANSI Inv	0,46	2
6	D	ANSI ModInv	4,85	2
7	E	ANSI VeryInv	21,6	2
8	F	ANSI ExtInv	29,1	2
9		ANSI LongInv	4,6	2
10		ANSI LongVeryInv	13,46	2
11		ANSI LongExtInv	30	2

The binary output status signals of the residual overcurrent protection function are the general starting signal and the general trip command if the time delay determined by the characteristics expired.

The residual overcurrent protection function has a binary input signal, which serves the purpose of disabling the function. The conditions of disabling are defined by the user, applying the graphic equation editor.

Technical data

Function	Value	Accuracy
Operating accuracy *	$20 \leq G_S \leq 1000$	< 3 %
Operate time accuracy		$\pm 5\%$ or ± 15 ms, whichever is greater
Reset ratio	0,95	
Reset time *		< 2% or ± 35 ms, whichever is greater
Dependent time char.		
Definite time char.	Approx 60 ms	
Transient overreach		2 %
Pickup time	≤ 40 ms	
Overshot time		
Dependent time char.	30 ms	
Definite time char.	50 ms	
Influence of time varying value of the input current (IEC 60255-151)		< 4 %

Measured in version $I_n = 200$ mA

Table 13 The technical data of the residual overcurrent protection function

Parameters

Enumerated parameters

Parameter name	Title	Selection range	Default
Parameter for type selection			
TOC51N_Oper_EPar_	Operation	Off, DefinitTime, IEC Inv, IEC VeryInv, IEC ExtInv, IEC LongInv, ANSI Inv, ANSI ModInv, ANSI VeryInv, ANSI ExtInv, ANSI LongInv, ANSI LongVeryInv, ANSI LongExtInv	Definite Time

Table 14 The enumerated parameters of the residual overcurrent protection function

Integer parameter

Parameter name	Title	Unit	Min	Max	Step	Default
Starting current parameter:						
TOC51N_StCurr_IPar_	Start Current *	%	5	200	1	50
TOC51N_StCurr_IPar_	Start Current **	%	10	1000	1	50

* $I_n = 1 A$ or $5 A$

** $I_n = 200 mA$ or $1 A$

Table 15 The integer parameter of the residual overcurrent protection function

Float point parameter

Parameter name	Title	Unit	Min	Max	Step	Default
Time multiplier of the inverse characteristics (OC module)						
TOC51N_Multip_FPar_	Time Multiplier	sec	0.05	999	0.01	1.0

Table 16 The float parameter of the residual overcurrent protection function

Timer parameters

Parameter name	Title	Unit	Min	Max	Step	Default
Minimal time delay for the inverse characteristics:						
TOC51N_MinDel_TPar_	Min Time Delay*	msec	0	60000	1	100
Definite time delay:						
TOC51N_DefDel_TPar_	Definite Time Delay**	msec	0	60000	1	100
Reset time delay for the inverse characteristics:						
TOC51N_Reset_TPar_	Reset Time*	msec	0	60000	1	100

*Valid for inverse type characteristics

**Valid for definite type characteristics only

Table 17 The timer parameters of the residual overcurrent protection function

Negative sequence overcurrent protection function (TOC46)

The negative sequence overcurrent protection function (TOC46) block operates if the negative sequence current is higher than the preset starting value.

In the negative sequence overcurrent protection function, definite-time or inverse-time characteristics are implemented, according to IEC or IEEE standards. The function evaluates a single measured current, which is the RMS value of the fundamental Fourier component of the negative sequence current. The characteristics are harmonized with IEC 60255-151, Edition 1.0, 2009-08.

The definite (independent) time characteristic has a fixed delaying time when the current is above the starting current G_s previously set as a parameter.

The standard dependent time characteristics of the negative sequence overcurrent protection function are as follows.

$$t(G) = TMS \left[\frac{k}{\left(\frac{G}{G_s}\right)^\alpha - 1} + c \right] \text{ when } G > G_s$$

where

$t(G)$ (seconds)

k, c

α

G

G_s

TMS

theoretical operate time with constant value of G ,

constants characterizing the selected curve (in seconds),

constant characterizing the selected curve (no dimension),

measured value of the characteristic quantity, Fourier base harmonic of the negative sequence current (INFour),

preset starting value of the characteristic quantity,

preset time multiplier (no dimension).

	IEC ref		k_r	c	α
1	A	IEC Inv	0,14	0	0,02
2	B	IEC VeryInv	13,5	0	1
3	C	IEC ExtInv	80	0	2
4		IEC LongInv	120	0	1
5		ANSI Inv	0,0086	0,0185	0,02
6	D	ANSI ModInv	0,0515	0,1140	0,02
7	E	ANSI VeryInv	19,61	0,491	2
8	F	ANSI ExtInv	28,2	0,1217	2
9		ANSI LongInv	0,086	0,185	0,02
10		ANSI LongVeryInv	28,55	0,712	2
11		ANSI LongExtInv	64,07	0,250	2

Table 18 The constants of the standard dependent time characteristics

A parameter (Operation) serves for choosing overcurrent function of independent time delay or dependent one with type selection above.

Time multiplier of the inverse characteristics (TMS) is also a parameter to be preset.

The end of the effective range of the dependent time characteristics (G_D) is:

$$G_D = 20 * G_s$$

Above this value the theoretical operating time is definite. The inverse type characteristics are also combined with a minimum time delay, the value of which is set by user parameter TOC46_MinDel_TPar_ (Min. Time Delay).

 info@microener.com +33(0)1 48 15 09 09	S24/LD (V4) Configuration description	FDE N°: 23AA3401021
		Rev. : A Page 21 sur 67

The negative phase sequence components calculation is based on the Fourier components of the phase currents.

The binary output status signals of the negative sequence overcurrent protection function are the general starting and the general trip command of the function.

The negative sequence overcurrent protection function has a binary input signal, which serves the purpose of disabling the function. The conditions of disabling are defined by the user, applying the graphic equation editor.

Technical data

Function	Value	Accuracy
Operating accuracy	$10 \leq G_s [\%] \leq 200$	< 2 %
Operate time accuracy		±5% or ±15 ms, whichever is greater
Reset ratio	0,95	
Reset time *		
Dependent time charact.		<2 % or ±35 ms, whichever is greater
Definite time charact.	approx. 60 ms	
Transient overreach		< 2 %
Pickup time at 2* G _s	<40 ms	
Overshot time		
Dependent time charact.	25 ms	
Definite time charact.	45 ms	
Influence of time varying value of the input current (IEC 60255-151)		< 4 %

* Measured with signal contacts

Table 19 Technical data of the negative sequence overcurrent protection function

Parameters

Enumerated parameter

Parameter name	Title	Selection range	Default
Parameter for type selection			
TOC46_Oper_EPar_	Operation	Off, DefinitTime, IEC Inv, IEC VeryInv, IEC ExtInv, IEC LongInv, ANSI Inv, ANSI ModInv, ANSI VeryInv, ANSI ExtInv, ANSI LongInv, ANSI LongVeryInv, ANSI LongExtInv	Definit Time

Table 20 The enumerated parameter of the negative sequence overcurrent protection function

Integer parameter

Parameter name	Title	Unit	Min	Max	Step	Default
Starting current parameter:						
TOC46_StCurr_IPar_	Start Current	%	5	200	1	50

Table 21 The integer parameter of the negative sequence overcurrent protection function

Timer parameters

Parameter name	Title	Unit	Min	Max	Step	Default
Minimal time delay for the inverse characteristics:						
TOC46_MinDel_TPar_	Min Time Delay*	msec	0	60000	1	100
Definite time delay:						
TOC46_DefDel_TPar_	Definite Time Delay**	msec	0	60000	1	100
Reset time delay for the inverse characteristics:						
TOC46_Reset_TPar_	Reset Time*	msec	0	60000	1	100
Time multiplier for the inverse characteristics:						
TOC46_Multip_TPar_	Time Multiplier*	msec	100	60000	1	100

**Valid for inverse type characteristics*

***Valid for definite type characteristics only*

Table 22 The timer parameter of the negative sequence overcurrent protection function

Line differential protection function (DIF87L)

The line differential protection function provides main protection for two terminal transmission lines. The line differential protection function does not apply vector shift compensation, thus transformers must be excluded from the protected section.

The operating principle is based on synchronized Fourier basic harmonic comparison between the line ends.

The devices at both line ends sample the phase currents and calculate the Fourier basic harmonic components. These components are exchanged between the devices synchronized via communication channels. The differential characteristic is a biased characteristic with two break points. Additionally, an unbiased overcurrent stage is applied, based on the calculated differential current.

The Smartline protection devices communicate via fiber optic cables. Generally, mono-mode cables are required, but for distances below 2 km a multi-mode cable may be sufficient. The line differential protection can be applied up to the distance of 120 km. (The limiting factor is the damping of the fiber optic channel: up to 30 dB is permitted to prevent the disturbance of operation.)

The hardware module applied is the CPU module of the PROTECTA protection device. The two devices are interconnected via the "process bus".

Technical data

Function	Value	Accuracy
Operating characteristic	2 breakpoints and unrestrained decision	
Reset ratio	0.95	
Characteristic accuracy (I _{bias} >2xI _n)		<2%
Operate time (I _{bias} >0.3xI _n)	Typically 35 ms	
Reset time	Typically 60 ms	

Table 23 Technical data of the line differential protection

Parameters

Enumerated parameter for the line differential protection function:

Parameter name	Title	Selection range	Default
Parameter to enable the line differential protection function:			
DIFF87L_Oper_EPar_	Operation	Off, On	Off

Table 24 The enumerated parameter of the line differential protection function

Integer parameters

Parameter name	Title	Unit	Min	Max	Step	Default
Parameters of the percentage characteristic curve:						
Base sensitivity:						
DIFF87L_f1_IPar_	Base Sensitivity	%	10	50	1	30
Slope of the second section of the characteristics:						
DIFF87L_f21_IPar_	1st Slope	%	10	50	1	30
Slope of the third section of the characteristics						
DIFF87L_f2_IPar_	2nd Slope	%	50	100	1	70
Bias limit of the first slope:						
DIFF87L_f2Brk_IPar_	1st Slope Bias Limit	%	100	400	1	200
Unrestrained line differential protection current level:						
DIFF87L_HS_IPar_	UnRst Diff Current	%	500	1500	1	800

Table 25 The integer parameters of the line differential protection function

Floating point parameters

Parameter name	Title	Unit	Min	Max	Step	Default
DIFF87L_LocalRatio_FPar_	Local Ratio	-	0.10	2.00	0.01	1.00
DIFF87L_RemoteRatio_FPar_	Remote Ratio	-	0.10	2.00	0.01	1.00

Table 26 The float parameters of the line differential protection function

Timer parameters

The line differential protection function does not have timers.

Line thermal protection function (TTR49L)

Basically, line thermal protection measures the three sampled phase currents. RMS values are calculated and the temperature calculation is based on the highest RMS value of the phase currents.

The temperature calculation is based on the step-by-step solution of the thermal differential equation. This method yields "overtemperature", meaning the temperature above the ambient temperature. Accordingly, the temperature of the protected object is the sum of the calculated "overtemperature" and the ambient temperature.

If the calculated temperature (calculated "overtemperature"+ambient temperature) is above the threshold values, alarm, trip and restart blocking status signals are generated.

For correct setting, the following values must be measured and set as parameters: rated load current is the continuous current applied for the measurement, rated temperature is the steady state temperature at rated load current, base temperature is the temperature of the environment during the measurement and the time constant is the measured heating/cooling time constant of the exponential temperature function.

When energizing the protection device, the algorithm permits the definition of the starting temperature as the initial value of the calculated temperature. The parameter Startup Term. is the initial temperature above the temperature of the environment as compared to the rated temperature above the temperature of the environment

The ambient temperature can be measured using e.g. a temperature probe generating electric analog signals proportional to the temperature. In the absence of such measurement, the temperature of the environment can be set using the dedicated parameter TTR49L_Amb_IPar_ (Ambient Temperature). The selection between parameter value and direct measurement is made by setting the binary Boolean parameter.

The problem of metal elements (the protected line) exposed to the sun is that they are overheated as compared to the „ambient“ temperature even without a heating current; furthermore, they are cooled mostly by the wind and the heat transfer coefficient is highly dependent on the effects of the wind. As the overhead lines are located in different geographical environments along the tens of kilometers of the route, the effects of the sun and the wind cannot be considered in detail. The best approximation is to measure the temperature of a piece of overhead line without current but exposed to the same environmental conditions as the protected line itself.

The application of thermal protection of the overhead line is a better solution than a simple overcurrent-based overload protection because thermal protection "remembers" the preceding load states of the line and the setting of the thermal protection does not need so a high security margin between the permitted current and the permitted continuous thermal current of the line. In a broad range of load states and in a broad range of ambient temperatures this permits the better exploitation of the thermal and consequently current carrying capacity of the line.

The thermal differential equation to be solved is:

$$\frac{d\Theta}{dt} = \frac{1}{T} \left(\frac{I^2(t)R}{hA} - \Theta \right), \text{ and the definition of the heat time constant is: } T = \frac{cm}{hA}$$

In this differential equation:

I(t) (RMS)	heating current, the RMS value usually changes over time;
R	resistance of the line;
c	specific heat capacity of the conductor;
m	mass of the conductor;
θ	rise of the temperature above the temperature of the environment;
h	heat transfer coefficient of the surface of the conductor;
A	area of the surface of the conductor;
t	time.

The solution of the thermal differential equation for constant current is the temperature as the function of time (the mathematical derivation of this equation is described in a separate document):

$$\Theta(t) = \frac{I^2 R}{hA} \left(1 - e^{-\frac{t}{T}} \right) + \Theta_o e^{-\frac{t}{T}}$$

where

Θ_o is the starting temperature.

Remember that the calculation of the measurable temperature is as follows:

$$\text{Temperature}(t) = \Theta(t) + \text{Temp_ambient}$$

where

Temp_ambient is the ambient temperature.

In a separate document it is proven that some more easily measurable parameters can be introduced instead of the aforementioned ones. Thus, the general form of equation above is:

$$H(t) = \frac{\Theta(t)}{\Theta_n} = \frac{I^2}{I_n^2} \left(1 - e^{-\frac{t}{T}} \right) + \frac{\Theta_o}{\Theta_n} e^{-\frac{t}{T}}$$

where:

$H(t)$ is the „thermal level“ of the heated object, this is the temperature as a percentage of the Θ_n reference temperature. (This is a dimensionless quantity but it can also be expressed in a percentage form.)

Θ_n is the reference temperature above the temperature of the environment, which can be measured in steady state, in case of a continuous I_n reference current.

I_n is the reference current (can be considered as the nominal current of the heated object). If it flows continuously, then the reference temperature can be measured in steady state.

$\frac{\Theta_o}{\Theta_n}$ is a parameter of the starting temperature related to the reference temperature

The *RMS calculations modul* calculate the RMS values of the phase currents individually. The sampling frequency of the calculations is 1 kHz; therefore, theoretically, the frequency components below 500Hz are considered correctly in the RMS values. This module is not part of the thermal overload function; it belongs to the preparatory phase.

The *Max selection module* selects the maximal value of the three RMS phase currents.

The *Thermal replica module* solves the first order thermal differential equation using a simple step-by-step method and compares the calculated temperature to the values set by parameters. The temperature sensor value proportional to the ambient temperature can be an input (this signal is optional, defined at parameter setting).

The function can be disabled by parameter, or generates a trip pulse if the calculated temperature exceeds the trip value, or generates a trip signal if the calculated temperature exceeds the trip value given by a parameter but it resets only if the temperature cools below the “Unlock temperature”.

The line thermal protection function has two binary input signals. The conditions of the input signal are defined by the user, applying the graphic equation editor. One of the signals can block the line thermal protection function, the other one can reset the accumulated heat and set the temperature to the defined value for the subsequent heating test procedure.

Technical data

Function	Accuracy
Operate time at $I > 1.2 \cdot I_{trip}$	<3 % or <+ 20 ms

Table 27 Technical data of the line thermal protection function

Parameters

Enumerated parameter

Parameter name	Title	Selection range	Default
Parameter for mode of operation			
TTR49L_Oper_EPar_	Operation	Off, Pulsed, Locked	Pulsed

Table 28 The enumerated parameter of the line thermal protection function

The meaning of the enumerated values is as follows:

- Off the function is switched off; no output status signals are generated;
- Pulsed the function generates a trip pulse if the calculated temperature exceeds the trip value
- Locked the function generates a trip signal if the calculated temperature exceeds the trip value. It resets only if the temperature cools below the "Unlock temperature".

Integer parameters

Parameter name	Title	Unit	Min	Max	Step	Default
Alarm Temperature						
TTR49L_Alm_IPar_	Alarm Temperature	deg	60	200	1	80
Trip Temperature						
TTR49L_Trip_IPar_	Trip Temperature	deg	60	200	1	100
Rated Temperature						
TTR49L_Max_IPar_	Rated Temperature	deg	60	200	1	100
Base Temperature						
TTR49L_Ref_IPar_	Base Temperature	deg	0	40	1	25
Unlock Temperature						
TTR49L_Unl_IPar_	Unlock Temperature	deg	20	200	1	60
Ambient Temperature						
TTR49L_Amb_IPar_	Ambient Temperature	deg	0	40	1	25
Startup Term.						
TTR49L_Str_IPar	Startup Term	%	0	60	1	0
Rated Load Current						
TTR49L_Inom_IPar_	Rated Load Current	%	20	150	1	100
Time constant						
TTR49L_pT_IPar_	Time Constant	min	1	999	1	10

Table 29 The integer parameters of the line thermal protection function

Boolean parameter

Boolean parameter	Signal title	Selection range	Default
Parameter for ambient temperature sensor application			
TTR49L_Sens_BPar_	Temperature Sensor	No, Yes	No

Table 30 The boolean parameter of the line thermal protection function

Inrush detection function (INR68)

When an inductive element with an iron core (transformer, reactor, etc.) is energized, high current peak values can be detected. This is caused by the transient asymmetric saturation of the iron core as a nonlinear element in the power network. The sizing of the iron core is usually sufficient to keep the steady state magnetic flux values below the saturation point of the iron core, so the inrush transient slowly dies out. These current peaks depend also on random factors such as the phase angle at energizing. Depending on the shape of the magnetization curve of the iron core, the detected peaks can be several times above the rated current peaks. Additionally, in medium or high voltage networks, where losses and damping are low, the indicated high current values may be sustained at length. Figure below shows a typical example for the inrush current shapes of a three-phase transformer.

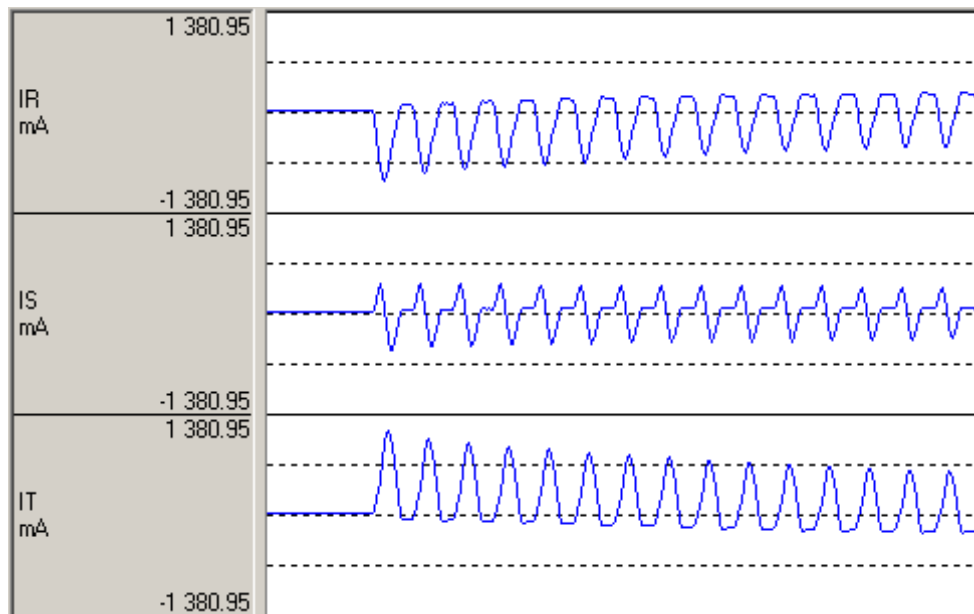

A typical inrush current

As a consequence, overcurrent relays, differential relays or distance relays may start, and because of the long duration of the high current peaks, they may generate an unwanted trip command.

The inrush current detection function can distinguish between high currents caused by overload or faults and the high currents during the inrush time.

The operating principle of the inrush current detection function is based on the special shape of the inrush current.

The typical inrush current in one or two phases is asymmetrical to the time axis. For example, in IT of the Figure above the positive peaks are high while no peaks can be detected in the negative domain.

The theory of the Fourier analysis states that even harmonic components (2nd, 4th etc.) are dominant in waves asymmetrical to the time axis. The component with the highest value is the second one.

Typical overload and fault currents do not contain high even harmonic components.

The inrush current detection function processes the Fourier basic harmonic component and the second harmonic component of the three phase currents. If the ratio of the second harmonic and the base Fourier harmonic is above the setting value of the parameter *2nd Harm Ratio*, an inrush detection signal is generated.

The signal is output only if the base harmonic component is above the level defined by the setting of the parameter *IPh Base Sens*. This prevents unwanted operation in the event that low currents contain relatively high error signals.

The function operates independently using all three phase currents individually, and additionally, a general inrush detection signal is generated if any of the phases detects inrush current.

The function can be disabled by the binary input *Disable*. This signal is the result of logic equations graphically edited by the user.

Using the inrush detection binary signals, other protection functions can be blocked during the transient period so as to avoid the unwanted trip.

Some protection functions use these signals automatically, but a stand-alone inrush detection function block is also available for application at the user's discretion.

Technical data

Function	Range	Accuracy
Current accuracy	20 ... 2000% of In	±1% of In

Table 31 Technical data of the inrush detection function

Parameters

Enumerated parameter

Parameter name	Title	Selection range	Default
Disabling or enabling the operation of the function			
INR2_Op_EPar_	Operation	Off,On	On

Table 32 The enumerated parameter of the inrush detection function

Integer parameters

Parameter name	Title	Unit	Min	Max	Step	Default
Ratio of the second and basic harmonic Fourier components						
INR2_2HRat_IPar_	2nd Harm Ratio	%	5	50	1	15
Basic sensitivity of the function						
INR2_MinCurr_IPar_	IPh Base Sens	%	20	100	1	30

Table 33 The integer parameter of the inrush detection function

Auto-reclose protection (REC79MV)

The MV automatic reclosing function can realize up to four shots of reclosing for medium-voltage networks. The dead time can be set individually for each reclosing and separately for earth faults and for multi-phase faults. All shots are of three phase reclosing.

The starting signal of the cycles can be generated by any combination of the protection functions or external signals of the binary inputs.

The automatic reclosing function is triggered if as a consequence of a fault a protection function generates a trip command to the circuit breaker and the protection function resets because the fault current drops to zero or the circuit breaker's auxiliary contact signals open state. According to the preset parameter values, either of these two conditions starts counting the dead time, at the end of which the MV automatic reclosing function generates a close command automatically. If the fault still exists or reappears, then within the "Reclaim time" the protection functions picks up again and the subsequent cycle is started. If the fault still exists at the end of the last cycle, the MV automatic reclosing function trips and generates the signal for final trip. If no pickup is detected within this time, then the MV automatic reclosing cycle resets and a new fault will start the procedure with the first cycle again.

At the moment of generating the close command, the circuit breaker must be ready for operation, which is signaled via the binary input "CB Ready". The preset parameter value "CB Supervision time" decides how long the MV automatic reclosing function is allowed to wait at the end of the dead time for this signal. If the signal is not received during this dead time extension, then the MV automatic reclosing function terminates.

Depending on binary parameter settings, the automatic reclosing function block can accelerate trip commands of the individual reclosing cycles. This function needs user-programmed graphic equations to generate the accelerated trip command.

The duration of the close command depends on preset parameter value "Close command time", but the close command terminates if any of the protection functions issues a trip command.

The MV automatic reclosing function can control up to four reclosing cycles. Depending on the preset parameter values "EarthFaults Rec,Cycle" and "PhaseFaults Rec,Cycle", there are different modes of operation, both for earth faults and for multi-phase faults:

Disabled	No automatic reclosing is selected,
1. Enabled	Only one automatic reclosing cycle is selected,
1.2. Enabled	Two automatic reclosing cycles are activated,
1.2.3. Enabled	Three automatic reclosing cycles are activated,
1.2.3.4. Enabled	All automatic reclosing cycles are activated.

The function can be switched Off /On using the parameter "Operation".

The user can also block the MV automatic reclosing function applying the graphic equation editor. The binary status variable to be programmed is "Block".

Depending on the preset parameter value "Reclosing started by", the MV automatic reclosing function can be started either by resetting of the TRIP command or by the binary signal indicating the open state of the circuit breaker.

If the reset state of the TRIP command is selected to start the MV automatic reclosing function, then the conditions are defined by the user applying the graphic equation editor. The binary status variable to be programmed is "AutoReclosing Start".

If the open state of the circuit breaker is selected to start the MV automatic reclosing function, then additionally to programming the "AutoReclosing Start" signal, the conditions for detecting the open state of the CB are defined by the user applying the graphic equation editor.

For all four reclosing cycles, separate dead times can be defined for line-to-line faults and for earth faults. The dead time counter of any reclosing cycle is started by the starting signal but starting can be delayed.

Reclosing is possible only if the conditions required by the "synchro-check" function are fulfilled. The conditions are defined by the user applying the graphic equation editor. The HV automatic reclosing function waits for a pre-programmed time for this signal. This time is defined by the user. If the "SYNC Release" signal is not received during the running time of this timer, then the "synchronous switch" operation is started. If no synchronous switching is possible, then the MV automatic reclosing function resets.

In case of a manual close command which is assigned to the binary input "Manual Close" using graphic equation programming, a preset parameter value decides how long the MV automatic reclosing function should be disabled after the manual close command.

The MV automatic reclosing function can be blocked by a binary input. The conditions are defined by the user applying the graphic equation editor.

Technical data

Function	Accuracy
Operating time	±1% of setting value or ±30 ms

Table 34 Technical data of the auto-reclosing protection function

Parameters

Enumerated parameters

Parameter name	Title	Selection range	Default
Switching ON/OFF the MV automatic reclosing function			
REC79_Op_EPar_	Operation	Off, On	On
Selection of the number of reclosing sequences in case of earth faults			
REC79_EFCycEn_EPar_	EarthFaultRe cCycle	Disabled, 1. Enabled, 1.2. Enabled, 1.2.3. Enabled, 1.2.3.4. Enabled	1. Enabled
Selection of the number of reclosing sequences in case of line-to-line faults			
REC79_PhFCycEn_EPar_	PhaseFaultR ecCycle	Disabled, 1. Enabled, 1.2. Enabled, 1.2.3. Enabled, 1.2.3.4. Enabled	1. Enabled
Selection of triggering the dead time counter (trip signal reset or circuit breaker open position)			
REC79_St_EPar_	Reclosing Started by	Trip reset, CB open	Trip reset

Table 35 The enumerated parameters of the auto-reclosing protection function

Timer parameters

Parameter name	Title	Unit	Min	Max	Step	Default
Dead time setting for the first reclosing cycle for line-to-line fault						
REC79_PhDT1_TPar_	1. Dead Time Ph	msec	0	100000	10	500
Dead time setting for the second reclosing cycle for line-to-line fault						
REC79_PhDT2_TPar_	2. Dead Time Ph	msec	10	100000	10	600
Dead time setting for the third reclosing cycle for line-to-line fault						
REC79_PhDT3_TPar_	3. Dead Time Ph	msec	10	100000	10	700
Dead time setting for the fourth reclosing cycle for line-to-line fault						
REC79_PhDT4_TPar_	4. Dead Time Ph	msec	10	100000	10	800
Dead time setting for the first reclosing cycle for earth fault						
REC79_EFDT1_TPar_	1. Dead Time EF	msec	0	100000	10	1000
Dead time setting for the second reclosing cycle for earth fault						
REC79_EF DT2_TPar_	2. Dead Time EF	msec	10	100000	10	2000
Dead time setting for the third reclosing cycle for earth fault						
REC79_EF DT3_TPar_	3. Dead Time EF	msec	10	100000	10	3000
Dead time setting for the fourth reclosing cycle for earth fault						
REC79_EF DT4_TPar_	4. Dead Time EF	msec	10	100000	10	4000
Reclaim time setting						
REC79_Rec_TPar_	Reclaim Time	msec	100	100000	10	2000
Impulse duration setting for the CLOSE command						
REC79_Close_TPar_	Close Command Time	msec	10	10000	10	100
Setting of the dynamic blocking time						
REC79_DynBlk_TPar_	Dynamic Blocking Time	msec	10	100000	10	1500
Setting of the blocking time after manual close command						
REC79_MC_TPar_	Block after Man Close	msec	0	100000	10	1000
Setting of the action time (max. allowable duration between protection start and trip)						
REC79_Act_TPar_	Action Time	msec	0	20000	10	1000
Limitation of the starting signal (trip command is too long or the CB open signal received too late)						
REC79_MaxSt_TPar_	Start Signal Max Time	msec	0	10000	10	1000
Max. delaying the start of the dead-time counter						
REC79_DtDel_TPar_	DeadTime Max Delay	msec	0	100000	10	3000
Waiting time for circuit breaker ready to close signal						
REC79_CBTO_TPar_	CB Supervision Time	msec	10	100000	10	1000
Waiting time for synchronous state signal						
REC79_SYN1_TPar_	SynCheck Max Time	msec	500	100000	10	10000
Waiting time for synchronous switching signal						
REC79_SYN2_TPar_	SynSW Max Time	msec	500	100000	10	10000

Table 36 The timer parameters of the auto-reclosing protection function

Boolean parameters

Parameter name	Title	Default	Explanation
REC79_CBState_BPar_	CB State Monitoring	0	Enable CB state monitoring for "Not Ready" state
REC79_Acc1_BPar_	Accelerate 1.Trip	0	Accelerate trip command at starting cycle 1
REC79_Acc2_BPar_	Accelerate 2.Trip	0	Accelerate trip command at starting cycle 2
REC79_Acc3_BPar_	Accelerate 3.Trip	0	Accelerate trip command at starting cycle 3
REC79_Acc4_BPar_	Accelerate 4.Trip	0	Accelerate trip command at starting cycle 4
REC79_Acc5_BPar_	Accelerate FinTrip	0	Accelerate final trip command

Table 37 The boolean parameters of the auto-reclosing protection function

Current unbalance function (VCB60)

The current unbalance protection function (VCB60) can be applied to detect unexpected asymmetry in current measurement.

The applied method selects maximum and minimum phase currents (RMS value of the fundamental Fourier components). If the difference between them is above the setting limit, the function generates a start signal. It is a necessary precondition of start signal generation that the maximum of the currents be above 10 % of the rated current and below 150% of the rated current.

The Fourier calculation modules calculate the RMS value of the basic Fourier current components of the phase currents individually. They are not part of the VCB60 function; they belong to the preparatory phase.

The analog signal processing module processes the RMS value of the basic Fourier current components of the phase currents to prepare the signals for the decision. It calculates the maximum and the minimum value of the RMS values and the difference between the maximum and minimum of the RMS values of the fundamental Fourier components of the phase currents as a percentage of the maximum of these values ($\Delta I >$). If the maximum of the currents is above 10 % of the rated current and below 150% of the rated current and the $\Delta I >$ value is above the limit defined by the preset parameter (Start Current Diff) an output is generated to the decision module.

The decision logic module combines the status signals to generate the starting signal and the trip command of the function.

The trip command is generated after the defined time delay if trip command is enabled by the Boolean parameter setting.

The function can be disabled by parameter setting, and by an input signal programmed by the user with the graphic programming tool.

Technical data

Function	Value	Accuracy
Pick-up starting accuracy at In		< 2 %
Reset ratio	0.95	
Operate time	70 ms	

Table 38 Technical data of the current unbalance function

Parameters**Enumerated parameter**

Parameter name	Title	Selection range	Default
Selection of the operating mode			
VCB60_Oper_EPar_	Operation	Off, On	On

Table 39 The enumerated parameter of the current unbalance function

Boolean parameter

Parameter name	Title	Explanation	Default
Selection for trip command			
VCB60_StOnly_BPar_	Start Signal Only	0 to generate trip command	0

Table 40 The boolean parameter of the current unbalance function

Integer parameter

Parameter name	Title	Unit	Min	Max	Step	Default
Phase difference current setting						
VCB60_StCurr_IPar_	Start Current Diff	%	10	90	1	50

*Table 41 The integer parameter of the current unbalance function***Timer parameter**

Parameter name	Title	Unit	Min	Max	Step	Default
Time delay						
VCB60_Del_TPar_	Time Delay	msec	100	60000	100	1000

Table 42 The timer parameter of the current unbalance function

Breaker failure protection function (BRF50MV)

After a protection function generates a trip command, it is expected that the circuit breaker opens and the fault current drops below the pre-defined normal level.

If not, then an additional trip command must be generated for all backup circuit breakers to clear the fault. At the same time, if required, a repeated trip command can be generated to the circuit breakers which are a priori expected to open.

The breaker failure protection function can be applied to perform this task.

The starting signal of the breaker failure protection function is usually the trip command of any other protection function. The user has the task to define these starting signals using the graphic equation editor as the "General Start" (BRF50MV_GenSt_GrO_). Individually phase starting is not available in the version of the function block described in this document. If these are needed, the function block "Breaker failure protection for solidly grounded networks" has to be used.

Dedicated timer starts at the rising edge of the general start signal for the backup trip command. During the running time of the timer the function optionally monitors the currents, the closed state of the circuit breakers or both, according to the user's choice. The selection is made using an enumerated parameter .

If current supervision is selected by the user then the current limit values must be set correctly. The binary input indicating the status of the circuit breaker has no meaning.

If contact supervision is selected by the user then the current limit values have no meaning. The binary input indicating the status of the circuit breaker must be programmed correctly using the graphic equation editor.

If the parameter selection is "Current/Contact", the current parameters and the status signal must be set correctly. The breaker failure protection function resets only if all conditions for faultless state are fulfilled.

If at the end of the running time of the backup timer the currents do not drop below the pre-defined level, and/or the monitored circuit breaker is still in closed position, then a backup trip command is generated.

The pulse duration of the trip command is not shorter than the time defined by setting the parameter Pulse length.

The breaker failure protection function can be disabled by setting the enabling parameter to "Off".

Dynamic blocking (inhibition) is possible using the binary input Block. The conditions are to be programmed by the user, using the graphic equation editor.

Technical data

Function	Effective range	Accuracy
Current accuracy		<2 %
BF time accuracy		± 5 ms
Current reset time	20 ms	

Parameters**Enumerated parameters**

Parameter name	Title	Selection range	Default
Selection of the operating mode			
BRF50MV_Oper_EPar_	Operation	Off, Current, Contact, Current/Contact	Off

Integer parameter

Parameter name	Title	Unit	Min	Max	Step	Default
Phase current setting						
BRF50MV_StCurrPh_IPar_	Start Ph Current	%	20	200	1	30
Neutral current setting						
BRF50MV_StCurrN_IPar_	Start Res Current	%	10	200	1	20

Timer parameters

Parameter name	Title	Unit	Min	Max	Step	Default
Time delay for trip command generation for the backup circuit breaker(s)						
BRF50MV_BUDel_TPar_	Backup Time Delay	msec	60	1000	1	200
Trip command impulse duration						
BRF50MV_Pulse_TPar_	Pulse Duration	msec	0	60000	1	100

Trip logic (TRC94)

The simple trip logic function operates according to the functionality required by the IEC 61850 standard for the "Trip logic logical node". This simplified software module can be applied if only three-phase trip commands are required, that is, phase selectivity is not applied.

The function receives the trip requirements of the protective functions implemented in the device and combines the binary signals and parameters to the outputs of the device.

The trip requirements are programmed by the user, using the graphic equation editor. The aim of the decision logic is to define a minimal impulse duration even if the protection functions detect a very short-time fault.

Technical data

Function		Accuracy
Impulse time duration	Setting value	<3 ms

Table 43 Technical data of the simple trip logic function

Parameters**Enumerated parameter**

Parameter name	Title	Selection range	Default
Selection of the operating mode			
TRC94_Oper_EPar_	Operation	Off, On	On

Tables 44 The enumerated parameter of the decision logic

Timer parameter

Parameter name	Title	Unit	Min	Max	Step	Default
Minimum duration of the generated impulse						
TRC94_TrPu_TPar_	Min Pulse Duration	msec	50	60000	1	150

Table 45 Timer parameter of the decision logic

Current input function (CT4)

If the factory configuration includes a current transformer hardware module, the current input function block is automatically configured among the software function blocks. Separate current input function blocks are assigned to each current transformer hardware module.

A current transformer hardware module is equipped with four special intermediate current transformers. As usual, the first three current inputs receive the three phase currents (IL1, IL2, IL3), the fourth input is reserved for zero sequence current, for the zero sequence current of the parallel line or for any additional current. Accordingly, the first three inputs have common parameters while the fourth current input needs individual setting.

The role of the current input function block is to

- set the required parameters associated to the current inputs,
- deliver the sampled current values for disturbance recording,
- perform the basic calculations
 - Fourier basic harmonic magnitude and angle,
 - True RMS value;
- provide the pre-calculated current values to the subsequent software modules,
- deliver the basic calculated values for on-line displaying.

Operation of the current input algorithm

The current input function block receives the sampled current values from the internal operating system. The scaling (even hardware scaling) depends on parameter setting. See parameters CT4_Ch13Nom_EPar_ (Rated Secondary I1-3) and CT4_Ch4Nom_EPar_ (Rated Secondary I4). The options to choose from are 1A or 5A (in special applications, 0.2A or 1A). This parameter influences the internal number format and, naturally, accuracy. (A small current is processed with finer resolution if 1A is selected.)

If needed, the phase currents can be inverted by setting the parameter CT4_Ch13Dir_EPar_ (Starpoint I1-3). This selection applies to each of the channels IL1, IL2 and IL3. The fourth current channel can be inverted by setting the parameter CT4_Ch4Dir_EPar_ (Direction I4). This inversion may be needed in protection functions such as distance protection, differential protection or for any functions with directional decision.

These sampled values are available for further processing and for disturbance recording.

The performed basic calculation results the Fourier basic harmonic magnitude and angle and the true RMS value. These results are processed by subsequent protection function blocks and they are available for on-line displaying as well.

The function block also provides parameters for setting the primary rated currents of the main current transformer. This function block does not need that parameter setting. These values are passed on to function blocks such as displaying primary measured values, primary power calculation, etc.

Technical data

Function	Range	Accuracy
Current accuracy	20 – 2000% of In	±1% of In

Table 46 Technical data of the current input

Parameters

Enumerated parameters

Parameter name	Title	Selection range	Default
Rated secondary current of the first three input channels. 1A or 5A is selected by parameter setting, no hardware modification is needed.			
CT4_Ch13Nom_EPar_	Rated Secondary I1-3	1A,5A	1A
Rated secondary current of the fourth input channel. 1A or 5A is selected by parameter setting, no hardware modification is needed.			
CT4_Ch4Nom_EPar_	Rated Secondary I4	1A,5A (0.2A or 1A)	1A
Definition of the positive direction of the first three currents, given by location of the secondary star connection point			
CT4_Ch13Dir_EPar_	Starpoint I1-3	Line,Bus	Line
Definition of the positive direction of the fourth current, given as normal or inverted			
CT4_Ch4Dir_EPar_	Direction I4	Normal,Inverted	Normal

Table 47 The enumerated parameters of the current input function

Floating point parameters

Parameter name	Title	Dim.	Min	Max	Default
Rated primary current of channel1					
CT4_PriI1_FPar_	Rated Primary I1	A	100	4000	1000
Rated primary current of channel2					
CT4_PriI2_FPar_	Rated Primary I2	A	100	4000	1000
Rated primary current of channel3					
CT4_PriI3_FPar_	Rated Primary I3	A	100	4000	1000
Rated primary current of channel4					
CT4_PriI4_FPar_	Rated Primary I4	A	100	4000	1000

Table 48 The floating point parameters of the current input function

NOTE: The rated primary current of the channels is not needed for the current input function block itself. These values are passed on to the subsequent function blocks.

The **measured values** of the current input function block.

Measured value	Dim.	Explanation
Current Ch - I1	A(secondary)	Fourier basic component of the current in channel IL1
Angle Ch - I1	degree	Vector position of the current in channel IL1
Current Ch - I2	A(secondary)	Fourier basic component of the current in channel IL2
Angle Ch - I2	degree	Vector position of the current in channel IL2
Current Ch - I3	A(secondary)	Fourier basic component of the current in channel IL3
Angle Ch - I3	degree	Vector position of the current in channel IL3
Current Ch - I4	A(secondary)	Fourier basic component of the current in channel I4
Angle Ch - I4	degree	Vector position of the current in channel I4

Table 49 The measured analogue values of the current input function

NOTE1: The scaling of the Fourier basic component is such that if pure sinusoid 1A RMS of the rated frequency is injected, the displayed value is 1A. (The displayed value does not depend on the parameter setting values "Rated Secondary".)

NOTE2: The reference of the vector position depends on the device configuration. If a voltage input module is included, then the reference vector (vector with angle 0 degree) is the vector calculated for the first voltage input channel of the first applied voltage input module. If no voltage input module is configured, then the reference vector (vector with angle 0 degree) is the vector calculated for the first current input channel of the first applied current input module.

Figure 1 shows an example of how the calculated Fourier components are displayed in the on-line block. (See the document "Smartline Remote user interface description".)

[-] CT4 module		
Current Ch - I1	<input type="text" value="0.84"/>	A
Angle Ch - I1	<input type="text" value="-9"/>	deg
Current Ch - I2	<input type="text" value="0.84"/>	A
Angle Ch - I2	<input type="text" value="-129"/>	deg
Current Ch - I3	<input type="text" value="0.85"/>	A
Angle Ch - I3	<input type="text" value="111"/>	deg
Current Ch - I4	<input type="text" value="0.00"/>	A
Angle Ch - I4	<input type="text" value="0"/>	deg

Figure 1 Example: On-line displayed values for the current input module

Circuit breaker control function block (CB1Pol)

The Circuit breaker control function block can be used to integrate the circuit breaker control of the PROTECTA device into the station control system and to apply active scheme screens of the local LCD of the device.

The Circuit breaker control function block receives remote commands from the SCADA system and local commands from the local LCD of the device, performs the prescribed checking and transmits the commands to the circuit breaker. It processes the status signals received from the circuit breaker and offers them to the status display of the local LCD and to the SCADA system.

Main features:

- Local (LCD of the device) and Remote (SCADA) operation modes can be enabled or disabled individually.
- The signals and commands of the synchro check / synchro switch function block can be integrated into the operation of the function block.
- Interlocking functions can be programmed by the user applying the inputs "EnaOff" (enabled trip command) and "EnaOn" (enabled close command), using the graphic equation editor.
- Programmed conditions can be used to temporarily disable the operation of the function block using the graphic equation editor.
- The function block supports the control models prescribed by the IEC 61850 standard.
- All necessary timing tasks are performed within the function block:
 - Time limitation to execute a command
 - Command pulse duration
 - Filtering the intermediate state of the circuit breaker
 - Checking the synchro check and synchro switch times
 - Controlling the individual steps of the manual commands
- Sending trip and close commands to the circuit breaker (to be combined with the trip commands of the protection functions and with the close command of the automatic reclosing function; the protection functions and the automatic reclosing function directly gives commands to the CB). The combination is made graphically using the graphic equation editor
- Operation counter
- Event reporting

The Circuit breaker control function block has binary input signals. The conditions are defined by the user applying the graphic equation editor. The signals of the circuit breaker control are seen in the binary input status list.

Technical data

Function	Accuracy
Operate time accuracy	±5% or ±15 ms, whichever is greater

Table 50 Technical data of the circuit breaker control function

Parameters

Enumerated parameter

Parameter name	Title	Selection range	Default
The control model of the circuit breaker node according to the IEC 61850 standard			
CB1Pol_ctlMod_EPar_	ControlModel*	Direct normal, Direct enhanced, SBO enhanced	Direct normal

**ControlModel*

- Direct normal: only command transmission
- Direct enhanced: command transmission with status check and command supervision
- SBO enhanced: Select Before Operate mode with status check and command supervision

Table 51 Enumerated parameter of the circuit breaker control function

Boolean parameter

Boolean parameter	Title	Explanation
CB1Pol_DisOverR_BPar_	Forced check	If true, then the check function cannot be neglected by the check attribute defined by the IEC 61850 standard

Table 52 Boolean parameter of the circuit breaker control function

Timer parameters

Parameter name	Title	Unit	Min	Max	Step	Default
Timeout for signaling failed operation						
CB1Pol_TimOut_TPar_	Max.Operating time	msec	10	1000	1	200
Duration of the generated On and Off impulse						
CB1Pol_Pulse_TPar_	Pulse length	msec	50	500	1	100
Waiting time, at expiry intermediate state of the CB is reported						
CB1Pol_MidPos_TPar_	Max.Intermediate time	msec	20	30000	1	100
Length of the time period to wait for the conditions of the synchron state. After expiry of this time, the synchro switch procedure is initiated (see synchro check/ synchro switch function block description)						
CB1Pol_SynTimOut_TPar_	Max.SynChk time	msec	10	5000	1	1000
Length of the time period to wait for the synchro switch impulse (see synchro check/ synchro switch function block description). After this time the function resets, no switching is performed						
CB1Pol_SynSWTimOut_TPar_	Max.SynSW time*	msec	0	60000	1	0
Duration of the waiting time between object selection and command selection. At timeout no command is performed						
CB1Pol_SBOTimeout_TPar_	SBO Timeout	msec	1000	20000	1	5000

** If this parameter is set to 0, then the "StartSW" output is not activated*

Table 53 Timer parameters of the circuit breaker control function

Available internal status variable and command channel

To generate an active scheme on the local LCD, there is an internal status variable indicating the state of the circuit breaker. Different graphic symbols can be assigned to the values.

Status variable	Title	Explanation
CB1Pol_stVal_Ist_	Status	Can be: 0: Intermediate 1: Off 2: On 3: Bad

The available control channel to be selected is:

Command channel	Title	Explanation
CB1Pol_Oper_Con_	Operation	Can be: On Off

Using this channel, the pushbuttons on the front panel of the device can be assigned to close or open the circuit breaker. These are the "Local commands".

Disconnecter control function (DisConn)

The Disconnecter control function block can be used to integrate the disconnector control of the PROTECTA device into the station control system and to apply active scheme screens of the local LCD of the device.

The Disconnecter control function block receives remote commands from the SCADA system and local commands from the local LCD of the device, performs the prescribed checking and transmits the commands to the disconnector. It processes the status signals received from the disconnector and offers them to the status display of the local LCD and to the SCADA system.

Main features:

- Local (LCD of the device) and Remote (SCADA) operation modes can be enabled or disabled individually.
- Interlocking functions can be programmed by the user applying the inputs "EnaOff" (enabled trip command) and "EnaOn" (enabled close command), using the graphic equation editor.
- Programmed conditions can be used to temporarily disable the operation of the function block using the graphic equation editor.
- The function block supports the control models prescribed by the IEC 61850 standard.
- All necessary timing tasks are performed within the function block:
 - Time limitation to execute a command
 - Command pulse duration
 - Filtering the intermediate state of the disconnector
 - Controlling the individual steps of the manual commands
- Sending trip and close commands to the disconnector
- Operation counter
- Event reporting

The Disconnecter control function block has binary input signals. The conditions are defined by the user applying the graphic equation editor. The signals of the disconnector control are seen in the binary input status list.

Technical data

Function	Accuracy
Operate time accuracy	±5% or ±15 ms, whichever is greater

Table 54 Technical data of the disconnector control function

Parameters

Enumerated parameters

Parameter name	Title	Selection range	Default
The control model of the disconnector node according to the IEC 61850 standard			
DisConn_ctlMod_EPar_	ControlModel*	Direct normal, Direct enhanced, SBO enhanced	Direct normal
Type of switch			
DisConn_SwTyp_EPar_	Type of Switch	N/A, Load break, Disconnector, Earthing Switch, HS Earthing Switch	Disconnector

*ControlModel

- Direct normal: only command transmission
- Direct enhanced: command transmission with status check and command supervision
- SBO enhanced: Select Before Operate mode with status check and command supervision

Table 55 Enumerated parameters of the disconnector control function

Boolean parameter

Boolean parameter	Title	Explanation
DisConn_DisOverR_BPar_	Forced check	If true, then the check function cannot be neglected by the check attribute defined by the IEC 61850 standard

Table 56 Boolean parameter of the disconnecter control function

Timer parameters

Parameter name	Title	Unit	Min	Max	Step	Default
Timeout for signaling failed operation						
DisConn_TimOut_TPar_	Max.Operating time	msec	10	20000	1	1000
Duration of the generated On and Off impulse						
DisConn_Pulse_TPar_	Pulse length	msec	50	30000	1	100
Waiting time, at expiry intermediate state of the disconnecter is reported						
DisConn_MidPos_TPar_	Max.Intermediate time	msec	20	30000	1	100
Duration of the waiting time between object selection and command selection. At timeout no command is performed						
DisConn_SBOTimeout_TPar_	SBO Timeout	msec	1000	20000	1	5000

Table 57 Timer parameters of the disconnecter control function

Available internal status variable and command channel

To generate an active scheme on the local LCD, there is an internal status variable indicating the state of the disconnecter. Different graphic symbols can be assigned to the values.

Status variable	Title	Explanation
DisConn I_stVal_Ist_	Status	Can be: 0: Intermediate 1: Off 2: On 3:Bad

The available control channel to be selected is:

Command channel	Title	Explanation
DisConn _Oper_Con_	Operation	Can be: On Off

Using this channel, the pushbuttons on the front panel of the device can be assigned to close or open the disconnecter. These are the "Local commands".

MEASURING FUNCTIONS

The measured values can be checked on the touch-screen of the device in the "On-line functions" page, or using an Internet browser of a connected computer. The displayed values are secondary voltages and currents, except the block "Line measurement". This specific block displays the measured values in primary units, using VT and CT primary value settings.

Analog value	Explanation
CT4 module	
Current Ch - I1	RMS value of the Fourier fundamental harmonic current component in phase L1
Angle Ch - I1	Phase angle of the Fourier fundamental harmonic current component in phase L1*
Current Ch - I2	RMS value of the Fourier fundamental harmonic current component in phase L2
Angle Ch - I2	Phase angle of the Fourier fundamental harmonic current component in phase L2*
Current Ch - I3	RMS value of the Fourier fundamental harmonic current component in phase L3
Angle Ch - I3	Phase angle of the Fourier fundamental harmonic current component in phase L3*
Current Ch - I4	RMS value of the Fourier fundamental harmonic current component in Channel I4
Angle Ch - I4	Phase angle of the Fourier fundamental harmonic current component in Channel I4*

*The reference angle is the phase angle of "Current Ch - I1"

Table 1 Measured analog values

CURRENT INPUT FUNCTION (CT4)

If the factory configuration includes a current transformer hardware module, the current input function block is automatically configured among the software function blocks. Separate current input function blocks are assigned to each current transformer hardware module.

A current transformer hardware module is equipped with four special intermediate current transformers. As usual, the first three current inputs receive the three phase currents (IL1, IL2, IL3), the fourth input is reserved for zero sequence current, for the zero sequence current of the parallel line or for any additional current. Accordingly, the first three inputs have common parameters while the fourth current input needs individual setting.

The role of the current input function block is to

- set the required parameters associated to the current inputs,
- deliver the sampled current values for disturbance recording,
- perform the basic calculations
 - Fourier basic harmonic magnitude and angle,
 - True RMS value;
- provide the pre-calculated current values to the subsequent software modules,
- deliver the basic calculated values for on-line displaying.

Operation of the current input algorithm

The current input function block receives the sampled current values from the internal operating system. The scaling (even hardware scaling) depends on parameter setting. See parameters CT4_Ch13Nom_EPar_ (Rated Secondary I1-3) and CT4_Ch4Nom_EPar_ (Rated Secondary I4). The options to choose from are 1A or 5A (in special applications, 0.2A or 1A). This parameter influences the internal number format and, naturally, accuracy. (A small current is processed with finer resolution if 1A is selected.)

If needed, the phase currents can be inverted by setting the parameter CT4_Ch13Dir_EPar_ (Starpoint I1-3). This selection applies to each of the channels IL1, IL2 and IL3. The fourth current channel can be inverted by setting the parameter CT4_Ch4Dir_EPar (Direction I4). This inversion may be needed in protection functions such as distance protection, differential protection or for any functions with directional decision.

These sampled values are available for further processing and for disturbance recording.

The performed basic calculation results the Fourier basic harmonic magnitude and angle and the true RMS value. These results are processed by subsequent protection function blocks and they are available for on-line displaying as well.

The function block also provides parameters for setting the primary rated currents of the main current transformer. This function block does not need that parameter setting. These values are passed on to function blocks such as displaying primary measured values, primary power calculation, etc.

Technical data

Function	Range	Accuracy
Current accuracy	20 – 2000% of In	±1% of In

Table 1 Technical data of the current input

Parameters

Enumerated parameters

Parameter name	Title	Selection range	Default
Rated secondary current of the first three input channels. 1A or 5A is selected by parameter setting, no hardware modification is needed.			
CT4_Ch13Nom_EPar_	Rated Secondary I1-3	1A,5A	1A
Rated secondary current of the fourth input channel. 1A or 5A is selected by parameter setting, no hardware modification is needed.			
CT4_Ch4Nom_EPar_	Rated Secondary I4	1A,5A (0.2A or 1A)	1A
Definition of the positive direction of the first three currents, given by location of the secondary star connection point			
CT4_Ch13Dir_EPar_	Starpoint I1-3	Line,Bus	Line
Definition of the positive direction of the fourth current, given as normal or inverted			
CT4_Ch4Dir_EPar_	Direction I4	Normal,Inverted	Normal

Table 2 The enumerated parameters of the current input function

Floating point parameters

Parameter name	Title	Dim.	Min	Max	Default
Rated primary current of channel1					
CT4_PriI1_FPar_	Rated Primary I1	A	100	4000	1000
Rated primary current of channel2					
CT4_PriI2_FPar_	Rated Primary I2	A	100	4000	1000
Rated primary current of channel3					
CT4_PriI3_FPar_	Rated Primary I3	A	100	4000	1000
Rated primary current of channel4					
CT4_PriI4_FPar_	Rated Primary I4	A	100	4000	1000

Table 3 The floating point parameters of the current input function

NOTE: The rated primary current of the channels is not needed for the current input function block itself. These values are passed on to the subsequent function blocks.

The **measured values** of the current input function block.

Measured value	Dim.	Explanation
Current Ch - I1	A(secondary)	Fourier basic component of the current in channel IL1
Angle Ch - I1	degree	Vector position of the current in channel IL1
Current Ch - I2	A(secondary)	Fourier basic component of the current in channel IL2
Angle Ch - I2	degree	Vector position of the current in channel IL2
Current Ch - I3	A(secondary)	Fourier basic component of the current in channel IL3
Angle Ch - I3	degree	Vector position of the current in channel IL3
Current Ch - I4	A(secondary)	Fourier basic component of the current in channel I4
Angle Ch - I4	degree	Vector position of the current in channel I4

Table 4 The measured analogue values of the current input function

NOTE1: The scaling of the Fourier basic component is such that if pure sinusoid 1A RMS of the rated frequency is injected, the displayed value is 1A. (The displayed value does not depend on the parameter setting values "Rated Secondary".)

NOTE2: The reference of the vector position depends on the device configuration. If a voltage input module is included, then the reference vector (vector with angle 0 degree) is the vector calculated for the first voltage input channel of the first applied voltage input module. If no voltage input module is configured, then the reference vector (vector with angle 0 degree) is the vector calculated for the first current input channel of the first applied current input module.

Figure 1 shows an example of how the calculated Fourier components are displayed in the on-line block.

[-] CT4 module		
Current Ch - I1	<input type="text" value="0.84"/>	A
Angle Ch - I1	<input type="text" value="-9"/>	deg
Current Ch - I2	<input type="text" value="0.84"/>	A
Angle Ch - I2	<input type="text" value="-129"/>	deg
Current Ch - I3	<input type="text" value="0.85"/>	A
Angle Ch - I3	<input type="text" value="111"/>	deg
Current Ch - I4	<input type="text" value="0.00"/>	A
Angle Ch - I4	<input type="text" value="0"/>	deg

Figure 1 Example: On-line displayed values for the current input module

DISTURBANCE RECORDER

The S24/LD (V4) configuration contains a disturbance recorder function. The details are described in the document shown in **Erreur ! Source du renvoi introuvable.**

Name	Title	Document
DRE	Disturbance Rec	<i>Disturbance recorder function block description</i>

Table 1 Implemented disturbance recorder function

The recorded analog channels:

Recorded analog signal	Explanation
IL1	Measured current for all overcurrent protection functions in line 1
IL2	Measured current for all overcurrent protection functions in line 2
IL3	Measured current for all overcurrent protection functions in line 3
I4	Measured current of the fourth current input channel (Io)

Table 2 Disturbance recorder, recorded analog channels

The recorded binary channels:

Recorded binary signal	Explanation
Trip	Trip command of the trip logic function
Inst OC Trip	Trip command of the 3ph instantaneous OC prot. function
Res Inst OC Trip	Trip command of the residual instantaneous OC prot. function
Time OC Start Low	Low setting stage start signal of the 3ph time OC prot. function
Time OC Start High	High setting stage start signal of the 3ph time OC prot. function
Res Time OC Start Low	Low setting stage start signal of the residual time OC prot. function
Res Time OC Start High	High setting stage start signal of the residual time OC prot. function
Therm OL Alarm	Alarm signal of the thermal overload prot.
Unbalance Start	Unbalance signal of the current unbalance prot. function

Table 3 Disturbance recorder, recorded binary channels

Enumerated parameter

Parameter name	Title	Selection range	Default
Parameter for activation			
DRE_Oper_EPar_	Operation	Off, On	Off

Table 4 The enumerated parameter of the disturbance recorder function

Timer parameters

Parameter name	Title	Unit	Min	Max	Step	Default
Pre-fault time:						
DRE_PreFault_TPar_	PreFault	msec	100	1000	1	200
Post-fault time:						
DRE_PostFault_TPar_	PostFault	msec	100	1000	1	200
Overall-fault time limit:						
DRE_MaxFault_TPar_	MaxFault	msec	500	10000	1	1000

Table 5 The timer parameters of the disturbance recorder function

TRIP CONTACT ASSIGNMENT

The procedures of command processing are shown in the following symbolical figure.

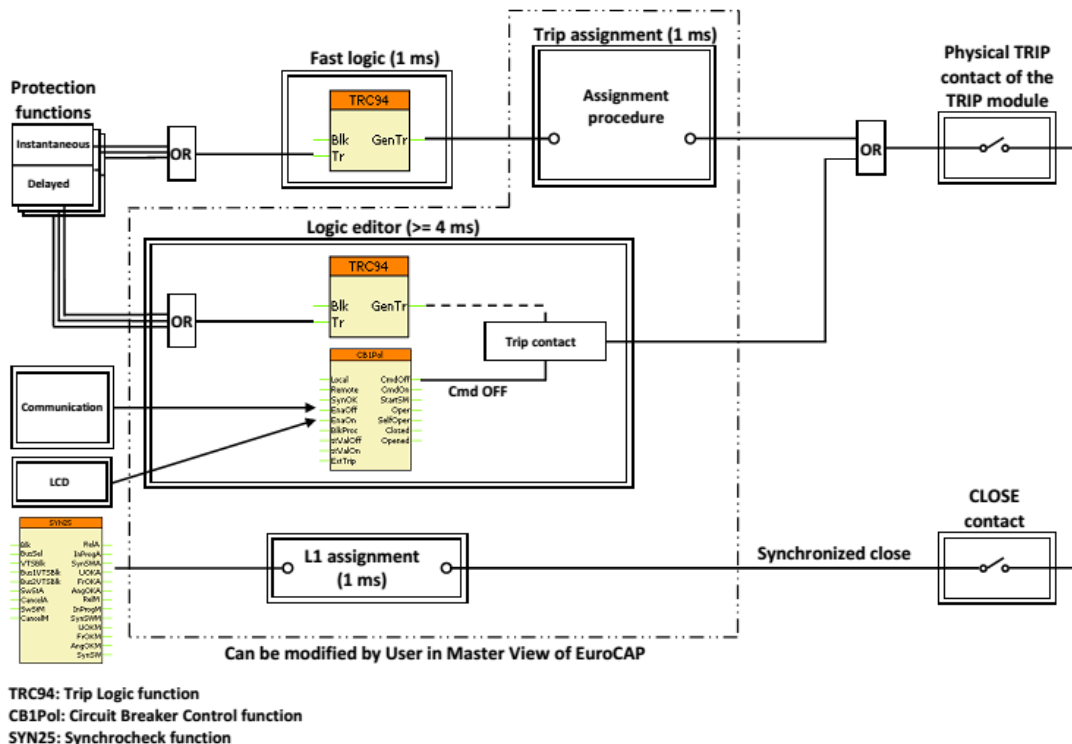

Figure 1 Principle of TRIP command processing

The left side of the Figure shows the available sources of the trip commands:

- The function blocks, configured in the device,
- The communication channels to the SCADA system,
- Commands generated using the front panel LCD of the device,
- Any other binary signals, e.g. signals from the binary inputs of the device.

The right side of the Figure shows one of the TRIP relays symbolically. The Figure provides a survey of the configured trip command processing methods. In the middle of the Figure, the locations indicated by "User" shows the possibilities for the user to modify the procedures. All other parts are factory programmed. The detailed description of the TRIP command processing can be found on the website in the following document: "Application of high – speed TRIP contacts".

The outputs of the "Simplified trip logic function" are connected directly to the contacts of the trip module (PSTP+/2101 module in position "A").

Binary status signal	Title	Connected to the contact PSTP+/2101 module in position "A"
TRC94_GenTr_GrI_	General Trip	Trip

Table 1 The connected signals of the phase-selective trip logic function

To the inputs of the "phase-selective trip logic function" some signals are assigned during factory configuration, some signals however depend on the programming by the user. **The conditions are defined by the user applying the graphic equation editor.** The factory defined inputs and the user defined inputs are in "OR" relationship.

Input	Binary status signal	Explanation
-------	----------------------	-------------

3Ph Trip	IOC50_GenTr_GrI_ OR IOC50N_GenTr_GrI_ OR DIFF87L_GenTr_GrI_	Trip command of the instantaneous overcurrent protection function OR Trip command of the residual instantaneous overcurrent protection function OR Trip command of the line differential protection function
Block	n.a.	Blocking the outputs of the phase-selective trip logic function

Table 2 The factory defined binary input signals of the trip logic function

The user defined signals are listed in **Erreur ! Source du renvoi introuvable..**

Input	Binary status signal	Explanation
3ph Trip	TRC94_GrO_	Request for three-phase trip command
Block	TRC94_Blk_GrO_	Blocking the outputs of the phase-selective trip logic function

Table 3 The user defined binary input signals of the trip logic function

LED ASSIGNMENT

On the front panel of the device there are "User LED"-s with the "Changeable LED description label" (See the document "**Quick start guide to the devices of the PROTECTA product line**"). Some LED-s are factory assigned, some are free to be defined by the user.

LED	Explanation
General Trip	Trip command generated by the trip logic function
OC Trip	Trip command generated by the phase OC protection functions
Res OC Trip	Trip command generated by the residual OC protection functions
Line diff. Trip	Trip command generated by the line diff. protection function
LED3105	Free LED, it can be configured by the costumer
LED3106	Free LED, it can be configured by the costumer
LED3107	Free LED, it can be configured by the costumer
AR Blocked	Blocked state of the automatic reclosing function
Therm alarm	Thermal prot. alarm signal
LED3110	Free LED, it can be configured by the costumer
LED3111	Free LED, it can be configured by the costumer
LED3112	Free LED, it can be configured by the costumer
LED3111	Free LED, it can be configured by the costumer
LED3112	Free LED, it can be configured by the costumer
LED3113	Free LED, it can be configured by the costumer
LED3115	Free LED, it can be configured by the costumer
LED3116	Free LED, it can be configured by the costumer
AutoReclose	Close command of auto-reclosing function

Table 1 LED assignment

EXTERNAL CONNECTION

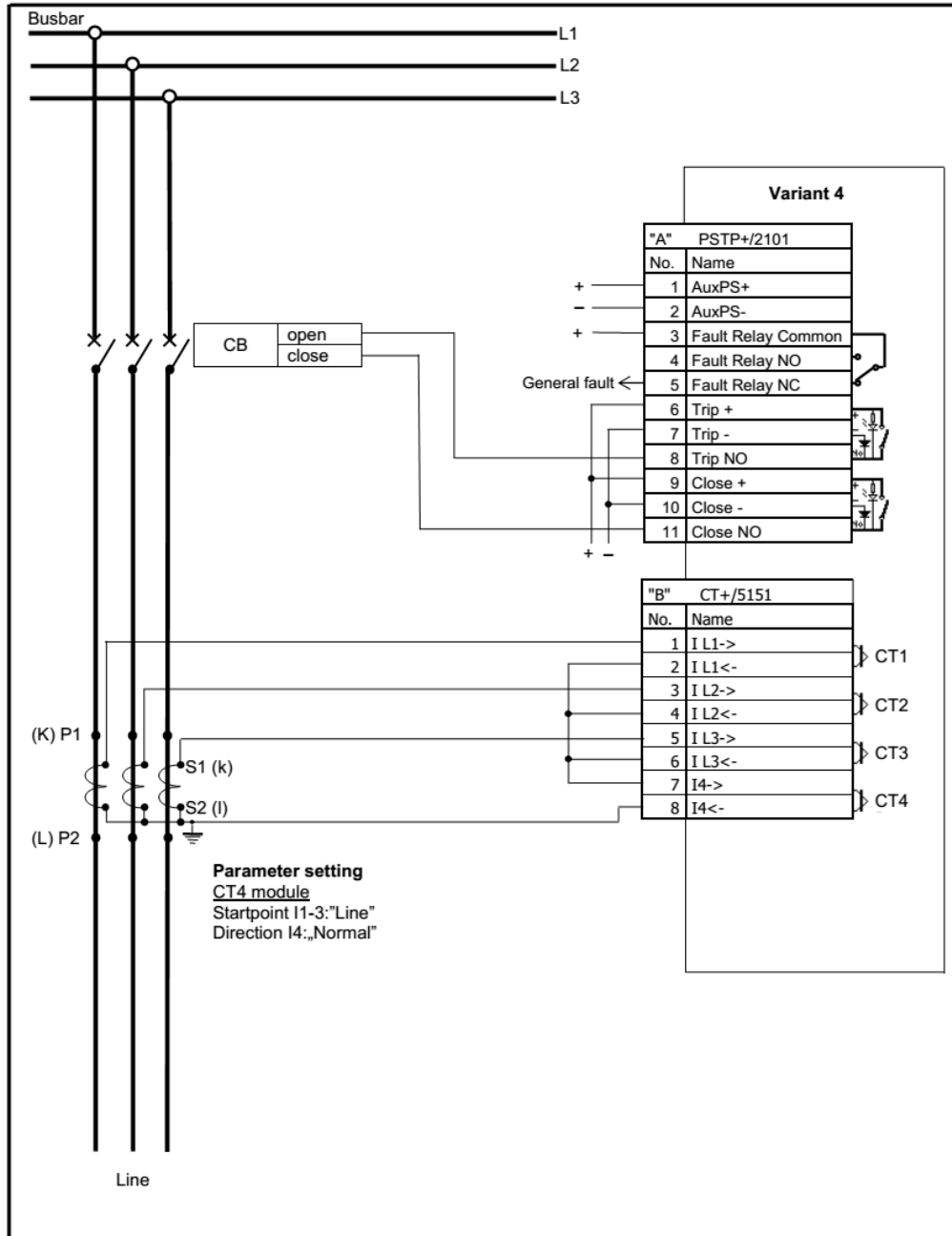

Edit by	Baloghné	Platform	S24/LD (V4)	
Checked	Tóth J.	Type		
Approved		Configuration		
Data	2014.07.10.	Subject	MV line differential protection and autorecloser in 24HP industrial enclosure.	ID
				PP-14-20556-00
				Pages: 1/1

HARDWARE SPECIFICATION

System design

The Smartline S24 protection device line is a scalable hardware platform to adapt to different applications. Data exchange is performed via a 16-bit high-speed digital non-multiplexed parallel bus with the help of a backplane module. Each module is identified by its location and there is no difference between module slots in terms of functionality. The only restriction is the position of the CPU module because it is limited to the "CPU" position. The built-in self-supervisory function minimizes the risk of device malfunctions.

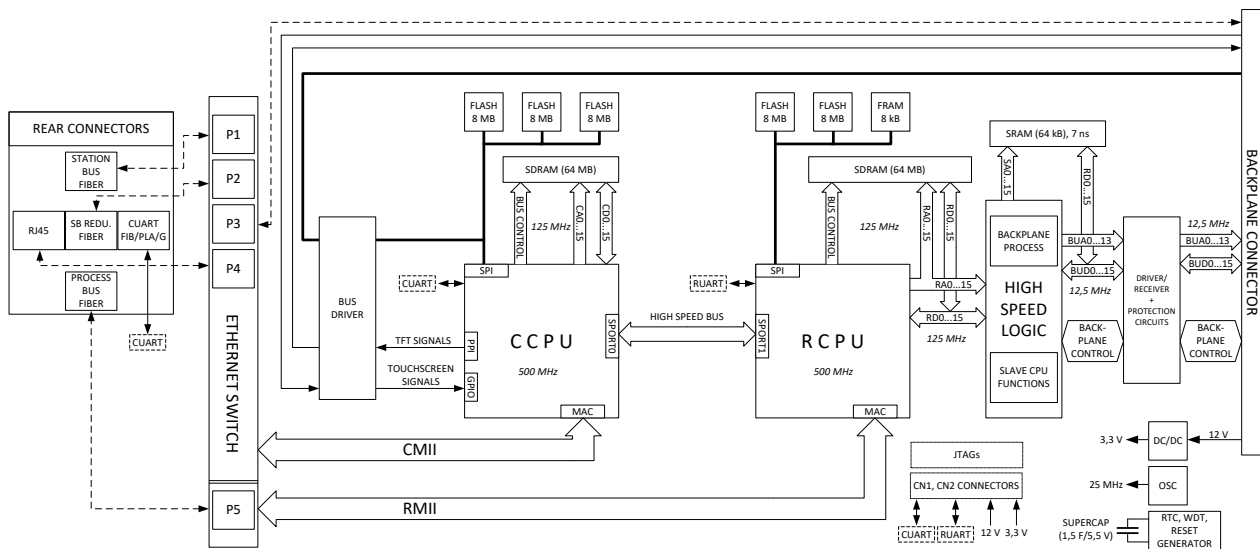

Figure 1 CPU block diagram

CPU module

CPU+ module

The CPU module contains all the protection, control and communication functions of the Smartline S24 device. Dual 500 MHz high-performance Analog Devices Blackfin processors separate relay functions (RDSP) from communication and HMI functions (CDSP). Reliable communication between processors is performed via high-speed synchronous serial internal bus (SPORT).

Each processor has its own operative memory such as SDRAM and flash memories for configuration, parameter and firmware storage. CDSP's operating system (uClinux) utilizes a robust JFFS flash file system, which enables fail-safe operation and the storage of disturbance record files, configuration and parameters.

Module handling

The RDSP core runs at 500 MHz and its external bus speed is 125 MHz. The backplane data speed is limited to approx. 20 MHz, which is more than enough for module data throughput. An additional logic element (CPLD and SRAM) is used as a bridge between the RDSP and the backplane. The CPLD collects analogue samples from CT/VT modules and also controls signaling outputs and inputs.

Fast startup

After power-up the RDSP processor starts up with the previously saved configuration and parameters. Generally, the power-up procedure for the RDSP and relay functions takes only a few seconds. That is to say, it is ready to trip within this time. CDSP's start-up procedure is longer because its operating system needs time to build its file system, initializing user applications such as HMI functions and the IEC61850 software stack.

HMI and communication tasks

- Embedded WEB-server:
 - Remote or local firmware upgrade possibility
 - Modification of user parameters
 - Events list and disturbance records
 - Password management
 - Online data measurement
 - Commands
 - Administrative tasks
- Front panel
 - TFT display handling: the interactive menu set is available through the TFT and the touchscreen interface
 - Black and white 128x64 pixels display with 4 tactile switches
- User keys:
 - tactile switches in B&W display configuration

The built-in 5-port Ethernet switch allows Smartline S24 to connect to IP/Ethernet-based networks. The following Ethernet ports are available:

- Station bus (100Base-FX Ethernet) SBW
- Redundant station bus (100Base-FX Ethernet) SBR
- Proprietary Process bus (100Base-FX Ethernet)
- RJ-45 Ethernet user interface
- Optional 10/100Base-T port via RJ-45 connector

Other communication:

- RS422/RS485 interfaces (galvanic interface to support legacy or other serial protocols, ASIF)
- Plastic or glass fiber interfaces to support legacy protocols, ASIF

Human-Machine Interface (HMI) module

The Smartline S24 device HMI consists of the following two main parts:

- HMI module, which is the front panel of the device,
- HMI functionality is the embedded web server and the intuitive menu system that is accessible through the HMI module. The web server is accessible via station bus or via RJ-45 Ethernet connector.

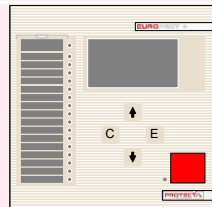
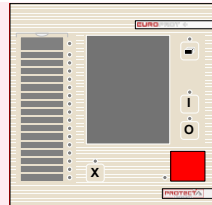
Module type	Display	User keys	Service port	Rack size	Illustration
HMI+2504	128 x 64 pixels, black and white	4 x tactile	RJ45 10/100Mbit/s	24 HP	
Optional HMI+2404	3,5" TFT	4 x tactile	RJ45 10/100Mbit/s	24 HP	

Main features of the HMI module

Function	Description
16 pieces user LEDs	Three-color, 3 mm circular LEDs
COM LED	Yellow, 3 mm circular LED indicating RJ-45 (on the front panel) communication link and activity
Device LED	1 piece three-color, 3 mm circular LED Green: normal device operation Yellow: device is in warning state Red: device is in error state
Tactile keys	Four tactile mechanical keys (On, Off, Page, LED acknowledgement)
Buzzer	Audible touch key pressure feedback
LED description	User changeable
3.5" or 128x64 pixels display	<ul style="list-style-type: none">• 128 * 64 pixel B&W display• 320 × 240 pixel TFT display with resistive touchscreen interface (optional)
Ethernet service port	IP56 rated Ethernet 10/100-Base-T interface with RJ-45 type connector

 info@microener.com +33(0)1 48 15 09 09	S24/LD (V4) Configuration description	FDE N°: 23AA3401021 Rev. : A Page 60 sur 67
--	--	--

Detailed modules description

Regarding the other hardware modules detailed descriptions please find it in Smartline S24 Hardware description see the hardware description of PROTECTA range on our web site : www.microener.com

GENERAL DATA

- Storage temperature: -40 °C ... +70 °C
- Operation temperature: -20 °C ... +55 °C
- Humidity: 10 % - 93 %

- EMC/ESD standard conformance:
 - Electrostatic discharge (ESD) EN 61000-4-2, IEC 60255-22-2, Class 3
 - Electrical fast transients (EFT/B) EN 61000-4-4, IEC 60255-22-4, Class A
 - Surges EN 61000-4-5, IEC 60255-22-5
 - Test voltages: line to earth 4 kV, line to line 1 kV
 - Conducted radio-frequency common mode EN 61000-4-6, IEC 60255-22-6, Level 3
 - 1 MHz damped oscillatory waves IEC 60255-22-1
 - Test voltage: 2.5 kV (for common and differential mode alike)
 - Voltage interruptions IEC 60255-11
 - Duration: 5 s, Criterion for acceptance: C
 - Voltage dips and short interruptions EN 61000-4-11
 - Voltage during dips: 0%, 40%, 70%
 - Power frequency magnetic field EN 61000-4-8, Level 4
 - Power frequency IEC 60255-22-7, Class A
 - Impulse voltage withstand test EN 60255-5, Class III
 - Dielectric test EN 60255-5, Class III
 - Insulation resistance test EN 60255-5
 - Insulation resistance > 15 GΩ

- Radiofrequency interference test (RFI):
 - Radiated disturbance EN 55011, IEC 60255-25
 - Conducted disturbance at mains ports EN 55011, IEC 60255-255
 - Immunity tests according to the test specifications IEC 60255-26 (2004), EN 50263 (1999), EN 61000-6-2 (2001) and IEC TS 61000-6-5 (2001)
 - Radiated radio-frequency electromagnetic field EN 61000-4-3, IEC 60255-22-3

- Vibration, shock, bump and seismic tests on measuring relays and protection equipment:
 - Vibration tests (sinusoidal), Class I, IEC 60255-21-1
 - Shock and bump tests, Class I, IEC 60255-21-2
 - Seismic tests, Class I, IEC 60255-21-3

Mechanical data

- Construction: anodized aluminum surface in tube
- EMC case protects against electromagnetic environmental influences and protects the environment from radiation from the interior
- IP20 protection from rear side (optional IP3X available)
- Size:
 - 24 HP, panel instrument case
 - Weight: max. 3 kg

Mounting methods of IED EP+S24

Mounting methods:

- Flush mounting panel instrument case with IP54 (front side), see 0-1. Figure
- Semi-flush mounting panel instrument case with IP54 (front side), see 0-1. Figure
- Din rail mounting with IP40 (front side), see 0-3. Figure

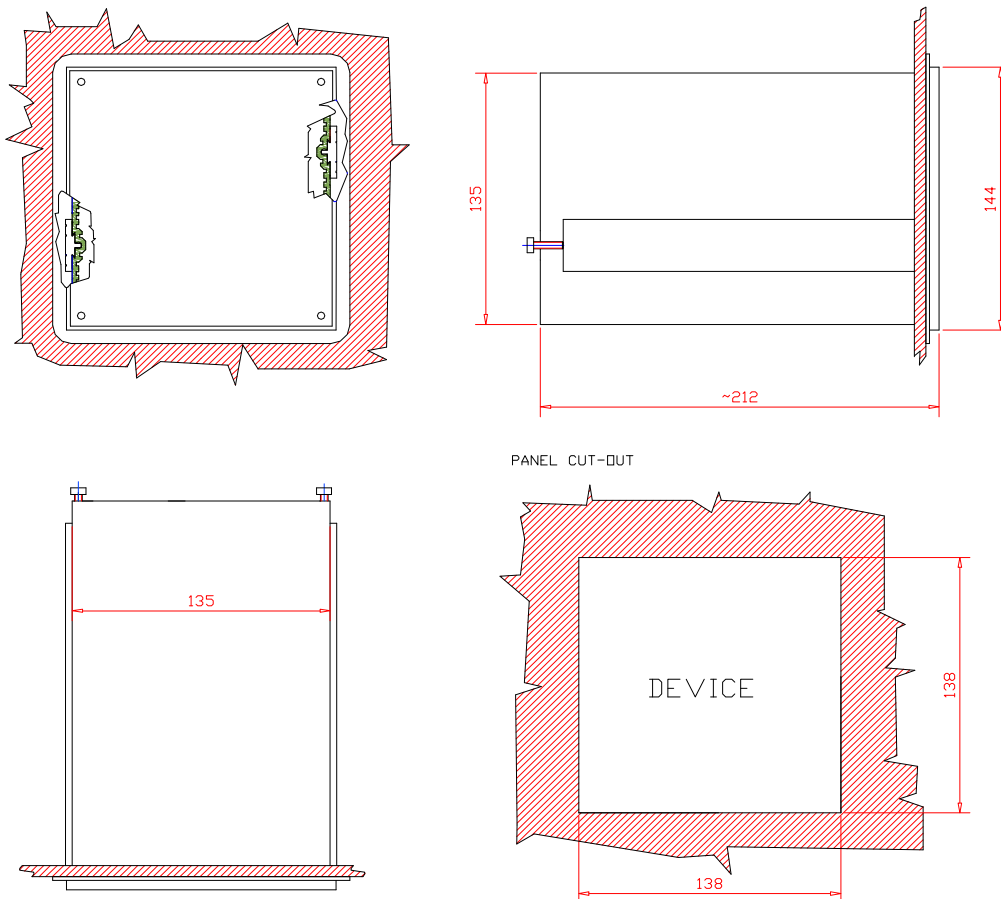
Flush mounting of 24 HP panel instrument case

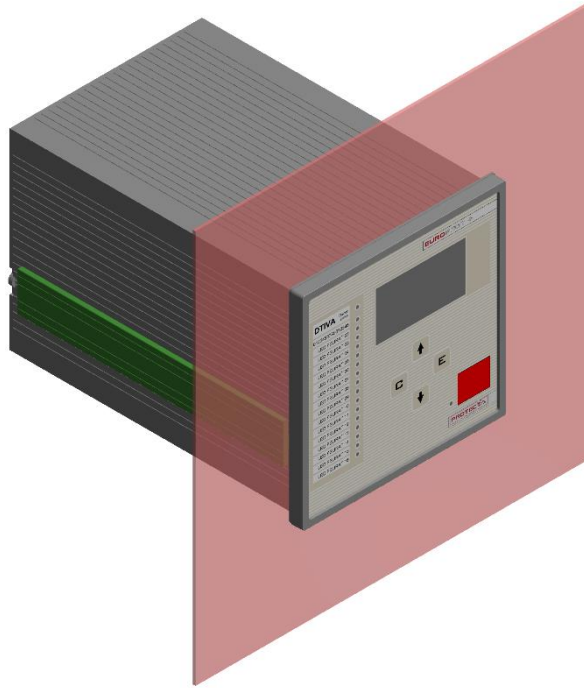

0-1. Figure S24 flush mounting method

Semi-flush mounting of 24 HP panel instrument case

The dimensions of the panel cut-out for this type of mounting method are the same as in case of flush mounting (138 mm × 138 mm). For semi flush mounting you only have to cut in two the fixing elements (with green colour in the 3D illustration below) and make the assembly as you can see in the pictures below.

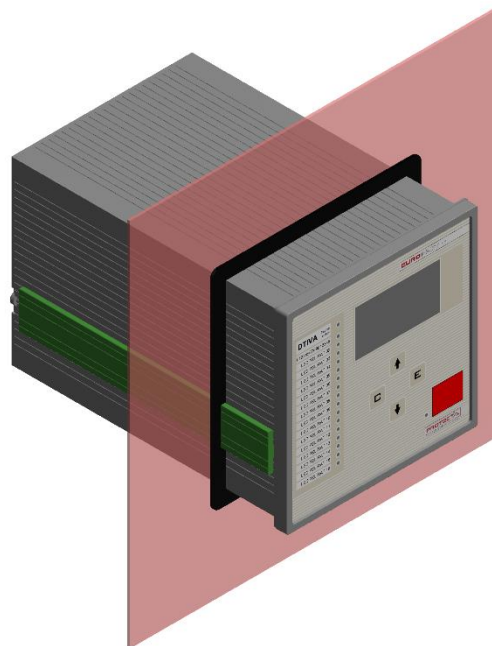
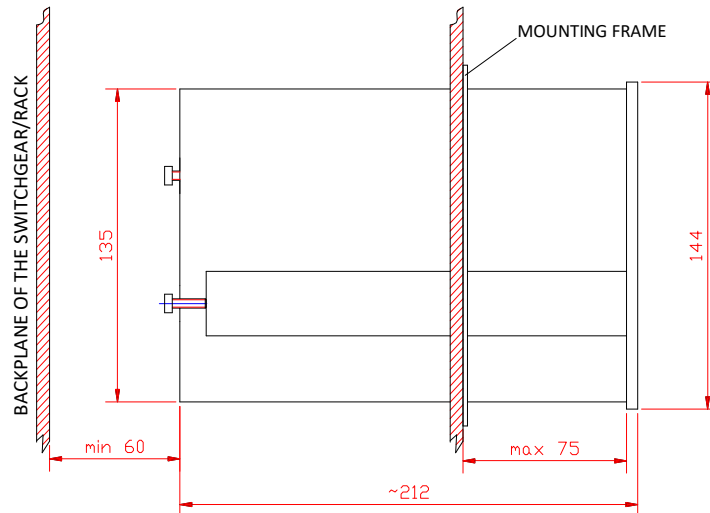

0-2. Figure S24 semi-flush mounting method (max. depth=75mm)

Din rail mounting of 24 HP panel instrument case

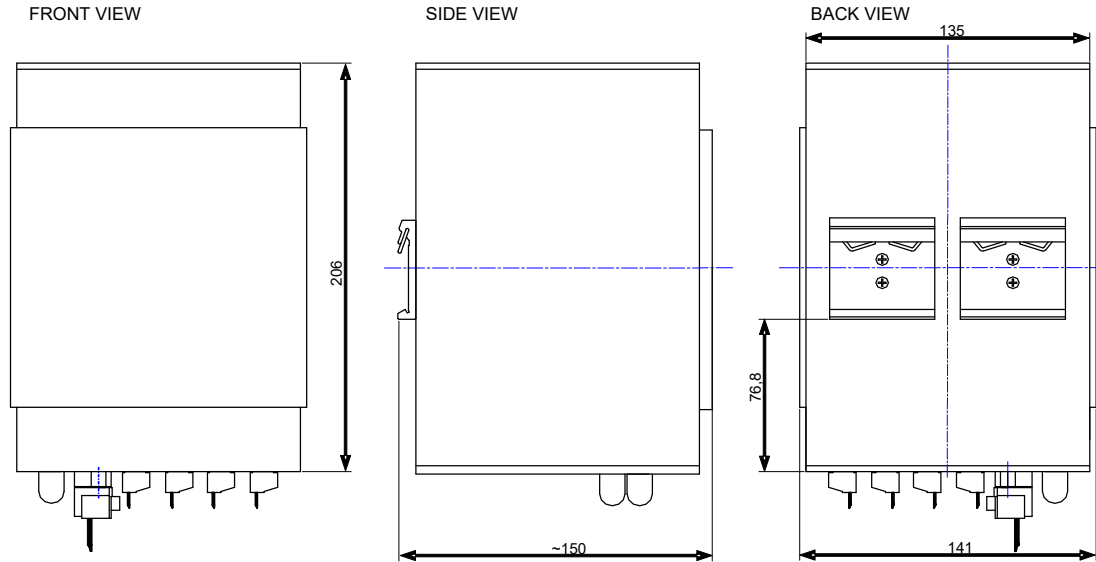

0-3. Figure S24 Din rail mounting

Communication

If the Smartline IED needs to be connected to legacy communication networks, the available options are

- Serial protocols (IEC 60870-5-101/103, Modbus RTU, DNP3, ABB-SPA)
- Network protocols (IEC 60870-5-104, DNP3, Modbus-TCP)
- Legacy network based protocols via 100Base-FX and 10/100Base-TX (RJ45)

Serial interfaces:

- optical (glass/fiber)
- RS485/RS422

All devices of the Smartline IED product range act on an Ethernet network as servers, exchanging with connected clients all information needed for continuous supervision of the entire power network

- Local or remote access to the device by widely used browsers (e.g. Internet Explorer, Mozilla Firefox, Opera, Google Chrome, PDAs, smart phones)
- Front panel image and system characteristics
- Parameter setting
- On-line information
- Event log
- Disturbance record download and fast view
- Command screen
- Scanning the connected devices
- Download of device documentation
- Advanced functions such as diagnostic information, password manager, update manager, device test

Application of the IEC61850 based communication assures interoperability of the Smartline IEDs with devices made by other manufacturers

- Native and configurable IEC61850 support for both vertical and horizontal communication
- Full range of devices both for high voltage and medium voltage protection tasks with IEC61850 compatibility

The time synchronization methods offered support easy matching in existing SCADA systems

- Primary and secondary NTP server
- Legacy protocol master
- Minute pulse
- IRIG-B000 or IRIG-B12X

