

Configuration du logiciel EUROCAP

FDE 23AA2420958\$B

La Protection électrique en toute Sérénité



MICROENER

Page vierge

GESTION DES MODIFICATIONS

Mod.	Description	Date	Création	Validation
A	Création du document en français	30/08/2023	AA	LA
B	Mise à jour du document - langue anglaise	24/01/2024	GJ	GJ

Sommaire

USED SYMBOLS	7
LIST OF ABBREVIATIONS	7
GENERAL	7
EUROCAP CONFIGURATION TOOL FOR EUROPROT+ DEVICES.....	7
Application	7
Starting the software	8
Access levels	8
The configuration	9
Active icons at starting the software.....	9
Active icons when a configuration is active	11
Other functions of the menu.....	13
Recovery.....	13
Compare	13
Print	14
Find	15
Information about the active configuration	16
Checking the configuration	17
Uploading the configuration.....	19
Understanding the configuration.....	22
The operation of the EuroProt+ devices	22
The configuration menu	25
The full configuration menu.....	25
The configuration menu in "Master view"	26
Hardware configuration.....	27
The Connector allocation.....	27
LED definition	28
The IO signals.....	32
Binary inputs	33
Binary outputs	33
Trip definition	35
Communication.....	37
Software configuration	37
Functions.....	37
Installed function blocks	37
Visible on HMI	40
Equations	41
Fast Logic.....	41
Normal Logic	41
Measured values	41
Parameters	41
Parameter description.....	42
Parameterset change.....	42
Busbar protection	43
Sectionalizers.....	43
Bay topology	44
Events.....	45
Disturbance recorder	47
Selecting a binary signal for disturbance recording	47
Selecting an analogue signal for disturbance recording	48
Control	49
Counters.....	50
Matrix	51
Matrix/ Inputs menu.....	51

Matrix / Outputs menu	52
THE LCD EDITOR.....	53
User's Manual for the LCD editor	55
Starting the LCD editor	55
The icons of the tool-bar	57
Creating new user screens	58
Composing a new user screen	69
THE OFFLINE PARAMETER SET EDITOR.....	79
Starting the off-line parameter set editor	80
Editing the parameter values.....	82
Setting options.....	82
Helptexts.....	83
Exporting and importing the parameter files to and from Excel files	84
Application of RIO files for testing.....	85
THE RACK DESIGNER	86
Designing the rack.....	86
Displaying the details of the I/O signals	90
THE GRAPHICAL LOGIC EDITOR.....	90
Application	90
Starting the graphical logic editor.....	91
Active icons at starting the graphical logic editor	91
Analogue signal assignment in logic editor	94
New VT & CT function blocks.....	94
Analogue input assignment for function blocks	94
Drawing new graphical logic.....	95
Printing graphic logic	100
Using macros	101
Macro definition and modification	102
Managing Macros	104
Logical sheet export/import.....	104
Sheet export.....	104
Export all sheets	104
Sheet import.....	104
Matching during the sheet import process	107
Import all sheets.....	109
Setting DOI descriptions for IEC 61850 Logical Nodes.....	109
EUROCAP COMMUNICATION CONFIGURATOR.....	110
Overview.....	110
IEC 61850.....	111
Export to and import from the system integrator	111
Logical nodes.....	112
IEC 61850 configuration.....	113
The data model	113
Logical Devices LD0	113
Logical Node LN0	113
Using the tree.....	113
Datasets.....	115
Reporting	117
GOOSE communication.....	118
GOOSE input mapping	120
IEC 60870-5-101 / 104	123

IEC 60870-5-103	125
DNP3	126

USED SYMBOLS



Additional information



Useful information for settings



Important part for proper usage

LIST OF ABBREVIATIONS

GENERAL

CB	Circuit Breaker
CDSP	Communication Digital Signals Processor
CT	Current Transformer
DSP function	Functionality realized in the Digital Signal Processor
IED	Intelligent Electronic Device
RBAC	Role-based Access Control
RDSP	Relay Digital Signal Processor
VT	Voltage Transformer

Related to IEC61850

CDC	Common Data Class
CID	Configured IED Description file
DA	Data Attribute
DOI	Digital Output Input
FCDA	Functional Constraint Data Attribute
GCB	GOOSE Control Block
GOOSE	Generic Object Oriented Substation Event
ICD	IED Capability Description file
RCB	Report Control Block
SCD	Substation Configuration Description file
SCL	Substation Configuration Description Language
SPS	Single Point Status

Related to other communication protocols

ASDU	Application Service Data Unit
CAD	Common Address
COT	Cause of Transmission
IOA	Information Object Address
SBO	Select Before Operate

EUROCAP CONFIGURATION TOOL FOR EUROPROT+ DEVICES

Application

- The EuroProt+ product line of Protecta Electronics Co. Ltd. has been designed to perform all
- protection,
 - supervision,
 - monitoring,
 - communication and
 - automatic control functions of the electric power system.
- The EuroProt+ type complex protection - in respect of hardware and software - is a modular device. The modules are assembled and configured according to the requirements. The functions of the device are determined by the software and the pre-set parameter values.

The EuroCap software is the general configuration tool for the EuroProt+ devices. This program is used to manage the hardware and software included in the device. This document describes the application of the tool. Protecta Electronics Co. Ltd. assembles the usual protective tasks in factory configurations using this software tool. In these devices, the user activates the loaded software modules, and then the parameters and the required additional services of the device must be set.

The EuroProt+ devices communicate on standard Ethernet networks; **parameter setting can be performed using the latest version of the recommended browsers** (Google Chrome, Mozilla Firefox, Microsoft Edge, Apple Safari). Further information on parameter setting can be found in the "Remote operation via web browser" section of the EuroProt+ Operating Manual with Troubleshooting Guide document available online under application guides on the Protecta website.

Starting the software

The configuration tool is started by clicking the icon . The usual Windows operating techniques can be used in the application. This description assumes that the user is familiar with the Windows operating system.

Access levels

The EuroCAP configuration tool has two "views". These views are the user levels configured with different access rights depending on the utility. These are the Master (general user level) and Administrator (factory user level) views.

For the EuroProt+ devices, customers need the "Master View". Consequently, this document describes the details of this mode only.



NOTE: The previously available "Normal" and "Designer" views are now done away with. Since the "Normal" view was a subset of the "Master" view, users can now use only the "Master view". Factory users can now use "Factory" or "Administrator" view which also includes the capabilities previously available with the "Designer" view. The

previously available change view icon  is also now inactive and greyed out.





The configuration

Active icons at starting the software

After starting the program, **two main icons** are active:

-  for opening a stored file. The alternative method of opening is to select "File / Open Ctrl+O" from the menu. In this case, a EuroProt+ configuration file (.epc / .epcs) can be opened for further processing using the usual Windows selection method. It is also possible to open a recently used file in "File / Open Recent" menu and select a file. Last 10 opened configuration files are stored here.
NOTE: Opening a configuration (.epcs) file which had been renamed from an external software prompts the user to save the file again before uploading the configuration to the device. This is to ensure consistent file name representation in EuroCAP and device web interface.
-  for uploading the configuration to a device connected to the Ethernet network. After clicking on the icon, one of the devices connected to the Ethernet network can be selected for processing. It takes a short time to find these devices, and then the "Select device" window is opened (See Figure 0-2). This window lists the responding devices together with their IP address, substation and device name and firmware identifiers. The selection is performed using the usual Windows methods. The alternative method of opening is to select "Project / Upload configuration" from the menu. In this case the user can choose between the current or previous version of the configuration stored in the device.

Additional active icons are:

-  for changing language of EuroCAP software
-  for setting the default window size of the EuroCAP software. The alternative method of setting is to select "View / Default Window Size" from the menu.
-  for opening the "About" information Window. The alternative method of opening is to select "Help / About" menu from the menu.
-  Print From Archive: you can print the Feedback Documentation directly from the report.zip file. Please note that the configuration file is not opened by the program, it is printed directly from the .zip archive file. This function is available for use with report.zip files generated from devices with CDSP version 2.8.13.1520 and higher.

NOTE: Archived files can only be extracted from a device that runs on system version 2.8. Consequently, this feature is only available for devices running on system version 2.8 and not 2.10.

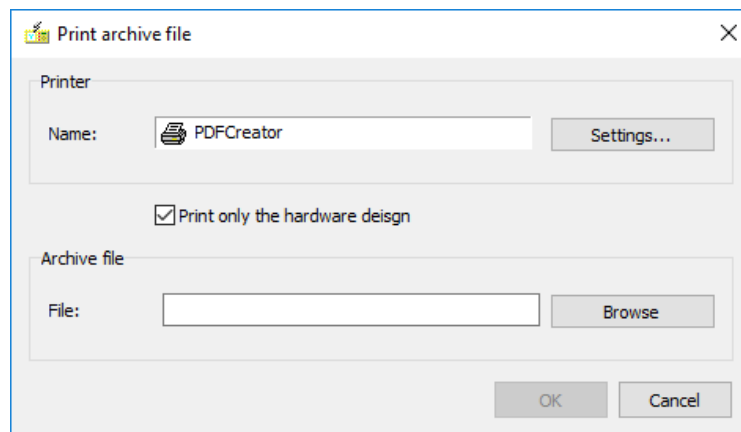

Figure 0-1 The "Print archive file" window

Additional information available through the Help menu:

- Version info, for opening a list of the changes applied in previous versions;
- "Protecta on the WEB" for opening the Protecta homepage;
- "SoftReal on the WEB" for opening the SoftReal homepage.

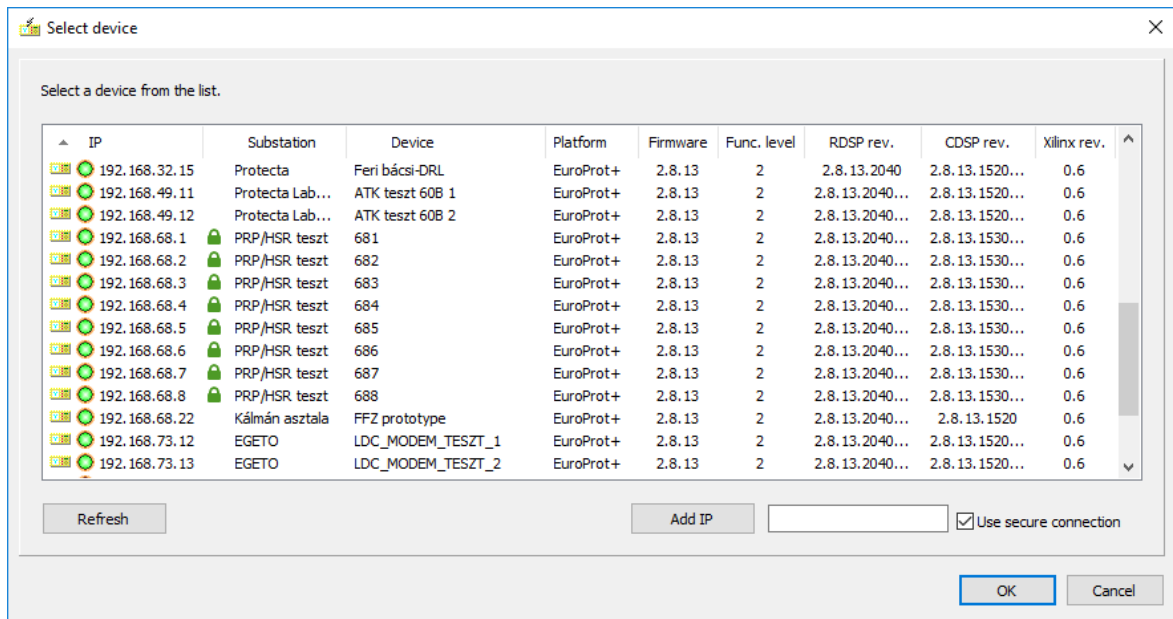

Figure 0-2 The "Select device" dialog

After selection and successful downloading (or after opening a stored configuration file), the window shown in Figure 0-2 opens automatically.

In case of secure file transfer (SFTP), the download window displays animated dots during connecting. An additional message line is also displayed: "It can take more than one minute in some cases.". Connect time-out is 120 seconds.

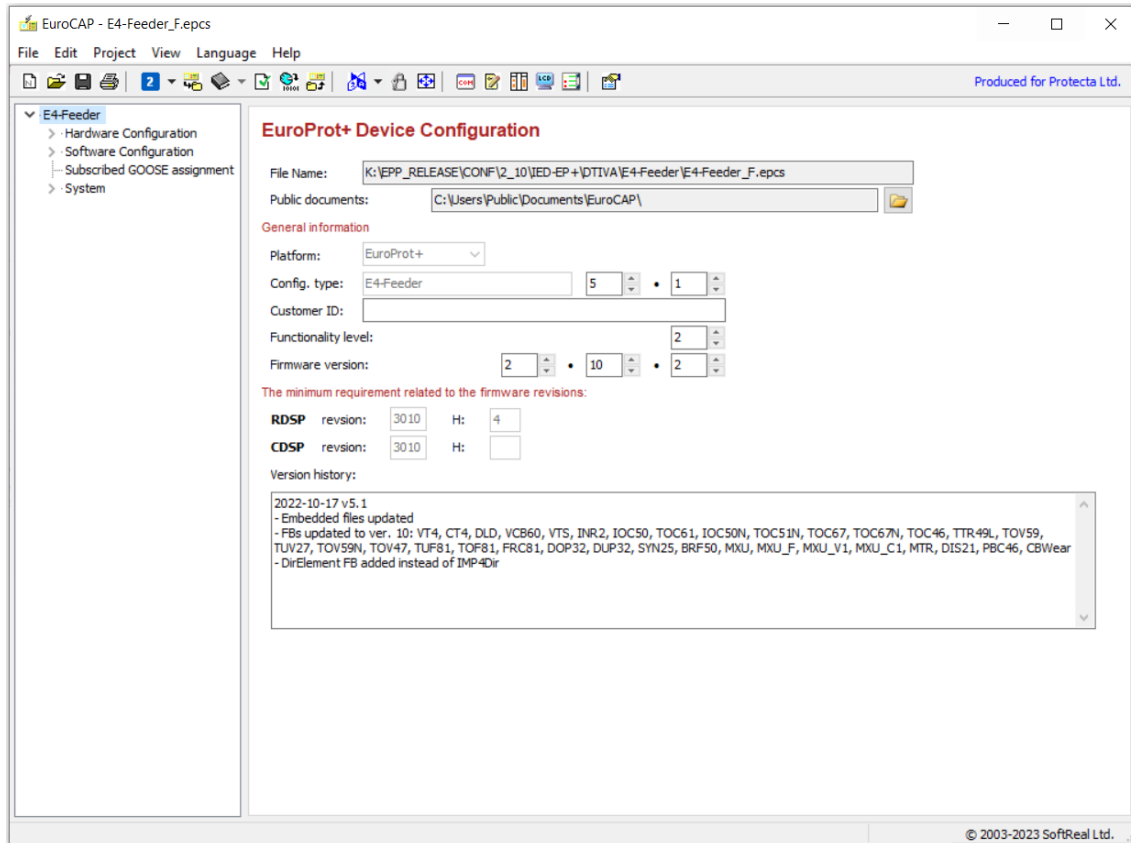







Figure 0-3 The EuroCAP – configuration main window













The main changes of the window, as compared to its starting state are:

- the activation of new icons on the toolbar (See below)
- a menu in the window on the left side: the Configuration menu (See Chapter 0)
- some basic information about the configuration (right side of the window, see Figure 0-3 above.)

Active icons when a configuration is active

If a configuration is active (a configuration file is opened or the configuration is downloaded from a device), then in addition to the basic icons (see Paragraph 0), the following main icons are also activated:

-  see Paragraph 0.
-  for saving the file on the computer. The alternative method saving is to select "File / Save Ctrl+S" from the menu. If the file name is to be modified or another path is to be selected, then click on the menu item "File / Save as". In this case, an .epc/.epcs EuroProt+ configuration file can be saved using the usual Windows selection method.
-  see Paragraph 0.
-  IEC 61850 icon has been introduced to select between the Edition 1 or Edition 2 version of the IEC 61850 implementation. The data model that is implemented in the device depends on the selection during configuration upload. If Edition 1 is selected, then Edition 1 data model will be implemented, likewise, if Edition 2 is selected, Edition 2 data model will be implemented.
-  see Paragraph 0.

-  for translation of the displayed text. By default, the text displayed on the LCD of the device and the web page of IED is generated in English. If the display needs to be in a different language, please contact Protecta Ltd.
-  for checking the active configuration. The alternative method of checking is to select "Project / Check configuration" from the menu. Before saving the .epc/.epcs EuroProt+ configuration file or building a downloadable version, it is advisable to check the file for syntactic errors using this icon or menu item. See Paragraph 0.
-  for generating communication files. Use this button to generate the necessary communication file e.g. .cid and .icd files for IEC 61850 communication, etc.
-  for uploading the opened configuration. The alternative method of uploading is to select "Project / Upload to Device" from the menu. Before uploading the files, the "Building" procedure must be run. If it has not been done yet, the software offers to do the processing. It is described in detail in Paragraph 0. uploading an .epc/.epcs file to device is also allowed in normal view.
-  see Paragraph 0.
-  see Paragraph 0.
-  see Paragraph 0.
-  for invoking the communication configuration menu, including IEC 61850 configuration. The communication configuration program is embedded software in the EuroCAP system; it is described in detail in Chapter 0. The alternative method of opening the communication configurator is to select "Project / Communication Configurator" from the menu.
-  for invoking the Logic editor for composing and modifying logic with the graphical method to extend the "PLC-like" functionality of the EuroProt+ devices. The Logic editor program is embedded software in the EuroCAP system; it is described in detail in Chapter 0. The alternative method of opening the Logic editor is to select "Project / Logic Editor" from the menu.
-  for launching the "Rack designer" embedded software. This software is needed for assembling the hardware modules of a EuroProt+ device. It is described in detail in Chapter 0.
-  for modifying the screens of the LCD on the front panel of the device. The alternative method of modifying is to select "Project / LCD parameters" from the menu. The LCD editor program is embedded software in the EuroCAP system; it is described in detail in Chapter 0.
-  for setting the operating parameters of the EuroProt+ devices. The alternative method of parameter setting is to select "Project / Offline Parameter Set Editor" from the menu. The aim of this option is to provide various kinds of access to the device within single software. The usual method of parameter setting for users is the internet browser mentioned in Paragraph 0. The Offline parameter set editor program is embedded software in the EuroCAP system; it is described in detail in Chapter 0.
-  see Paragraph 0.

Other functions of the menu

Recovery

The following functions are available in "File / Recovery" menu. This function is available to use with report.zip files generated from devices with CDSP version 2.8.13.1520 or later.

- Open From Archive: user can also open the configuration file from within a report.zip file with this menu command. When the file is opened, you are offered to save it with its original name (much like when you download a file from the device).
- Print Archive File: Documentation of the IED can be printed from the xxxx_report.zip file.
- Extract Parameter Files: the parameter setting file can be extracted from the existing report.zip. The user can select a folder and save the .par file there. You can open it in the Offline Parameter Set Editor, please see Chapter 0.
- Extract Log Files: there are .log files in the report.zip which helps the Protecta staff to troubleshoot and advise the customer when a problem appears. Users also can see these log files, however they may not understand the exact meaning of it. These .log files can be extracted and saved to a selected location in the menu.

Compare

Available in the "File / Compare" menu, this function is used to compare the logic equations (graphical, normal or fast) of two configurations. It compares the equations of the currently-opened configuration to the equations of another configuration which can be selected from the pop-up window that appears when the "compare" button is clicked.

If there are differences, they will be displayed in a "Compare configuration" pop-up window. See Figure 0-4 below:

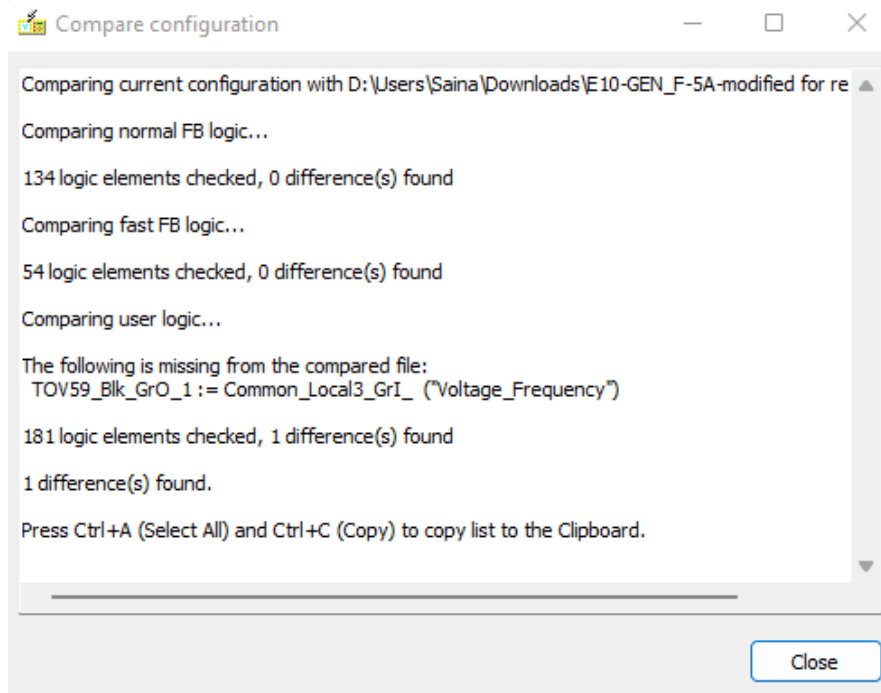

Figure 0-4 Result of compared configurations, difference found in graphical user equations

Print

This function is available in "File / Print" Ctrl+P menu to print the Feedback Documentation of the current configuration file optionally together with the system and parameter settings file.

NOTE: The last saved configuration file can be printed. Please save the current configuration file before printing.

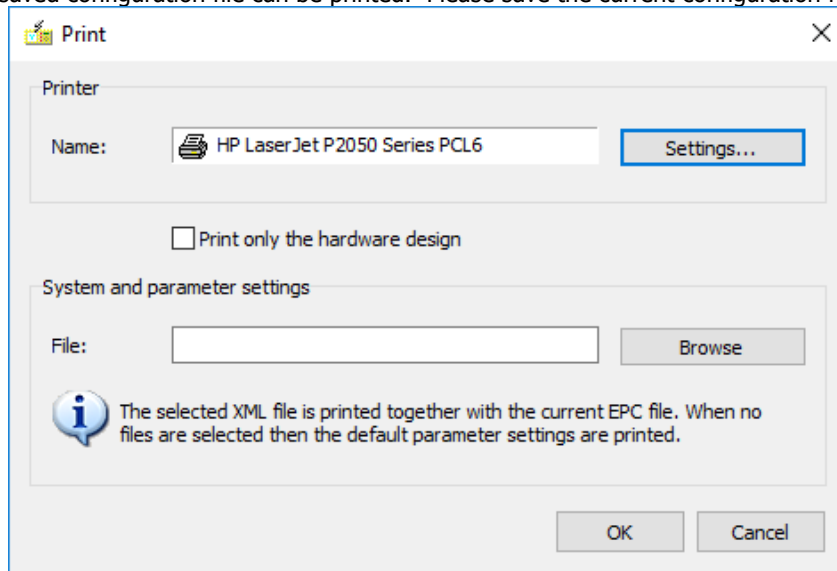

Figure 0-5 The "Print" menu

The optional "System and parameter settings" can be taken from an XML file extracted from the web page of the device. It contains the actual system settings and protection parameters. This XML file is not mandatory for printing. If it is not selected, the factory default parameters will be included in the Feedback Documentation.

Users can print a hardware design only which contains the Rack design and Connection assignment list, if the

Print only the hardware design is selected.

The Feedback Documentation contains the following information:

- System settings
- Firmware
- Configuration files
- Rack design
- Connection assignment
- Function blocks of the configuration
- On-line measurands
- Event channels
- Disturbance record channels
- Trip assignment
- LED assignment
- Counter functions
- IEC 60870-5-101/104 configuration settings
- IEC 60870-5-103 configuration settings
- IEC 61850 communication settings
- DNP3 configuration settings
- Logic editor configuration
- Parameter settings

Find

This function is available in "Edit / Find" Ctrl+F menu.
User can find a text in the configuration file, see Figure 0-6 below.

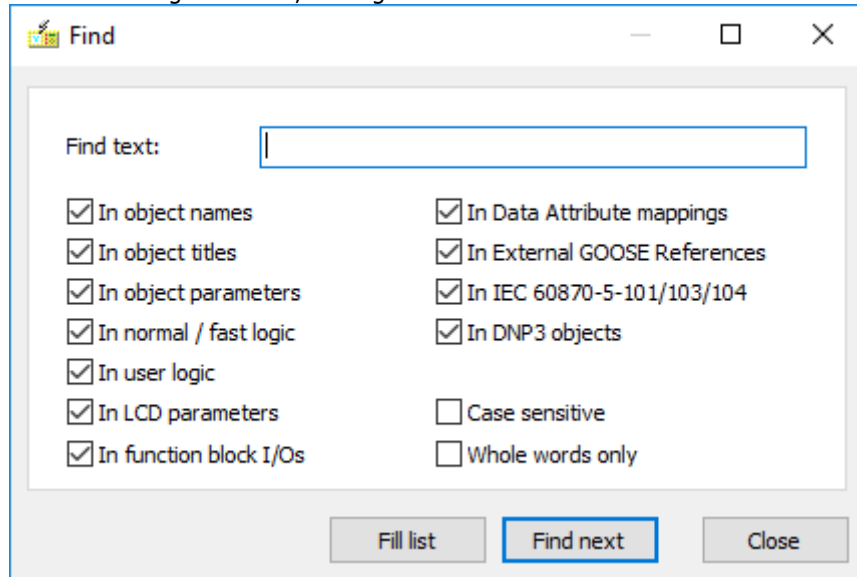

Figure 0-6 The "Find" window

Information about the active configuration

On the right side of the window, information about the active configuration is displayed. (See Figure 0-7.)

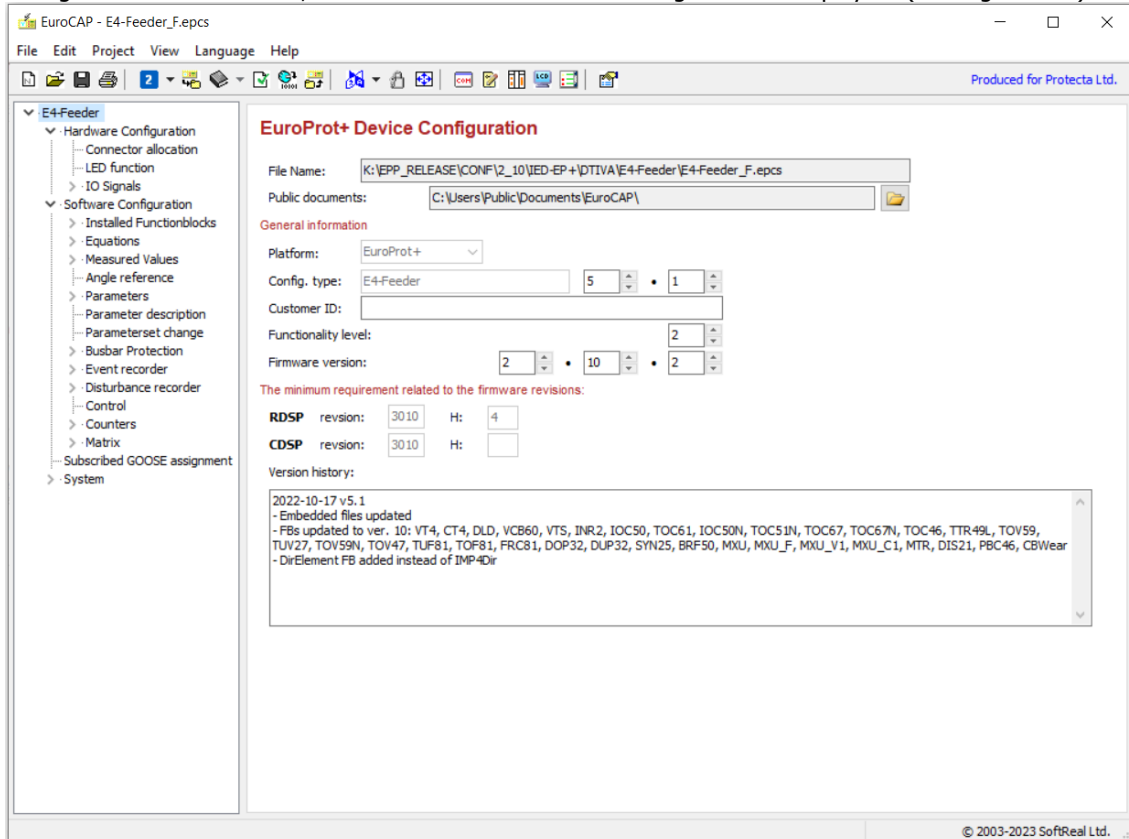

Figure 0-7 Information about the active configuration

Here, the "File Name" shows the path and file name of the saved configuration document (assigned at saving).

The "Public documents" show where the generated documents, e.g.: "cid" and "icd" files belonging to the IEC 61850 communication are (or will be) stored.

The "Config type" is the identifier displayed also on the local LCD of the device. The major and minor version numbers after it shows the factory version of the configuration file. These fields and the "Platform", the "Functionality" and the "Firmware version" cannot be changed in Master view, they belong to the factory configuration.

The "Firmware version" and "Functionality level" specify the requirements to upload the configuration into a CPU. For detailed information please read Paragraph 0.

The "Customer ID" is the identifier for special user version of the configuration.

The minimum requirement of RDSP and CDSP defines the minimum or the fixed version of firmwares. Below these versions the configuration cannot run properly. The EuroCAP does not allow the uploading a configuration, which requires higher firmware version than the CPU actually has.

The Master user can make notes of configuration changes in "Version history" field.

Checking the configuration

Before the configuration can be uploaded to the device, it has to be checked for any errors and saved as a .epcs file. The check configuration  button is used for this function.

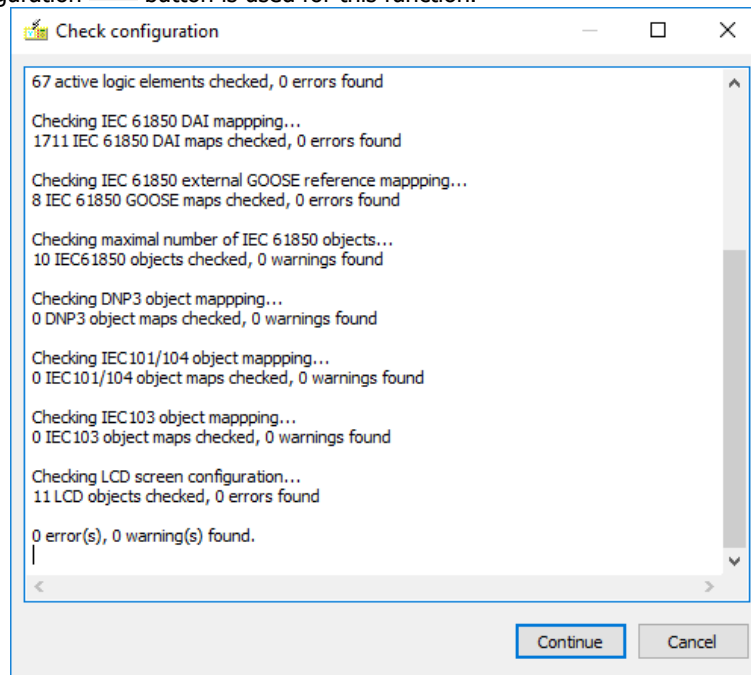

Figure 0-8 Check configuration window

If an error is found, when the configuration is saved, it is saved without a digital signature, as an .epc file. If there are no errors, the configuration will be saved as a .epcs file. Figure 0-9 below shows the pop-up dialogue box when the user tries to save a configuration file with errors.

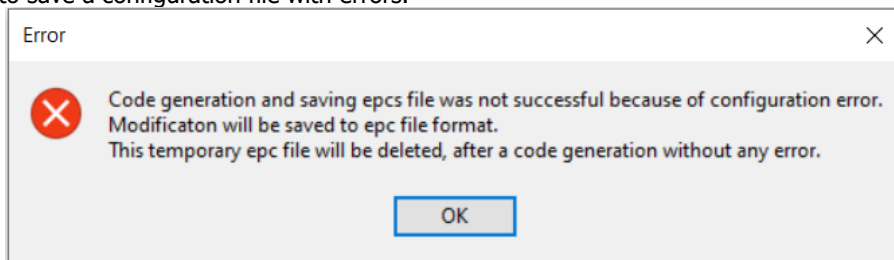

Figure 0-9 The pop-up message generated when the configuration cannot be saved with a digital signature

Files saved with a .epc extension can no longer be uploaded to the device. They can be saved but not uploaded. In order to be able to upload the file, all errors in the configuration flagged by the "check configuration" function have to be fixed.

The "Check configuration" function checks the maximal number of IEC 61850 objects (datasets, FCDAs, RCBs and GCBs), the user logic, trip assignment, the numbers of different variables, IEC 101/103/104 and DNP3 mapping, LCD configuration.

Object parameters in trip assignment are mandatory and they are also checked.

In case the number of IEC 61850 objects exceed the limit, the "check configuration" function will generate warnings but the configuration will still be saved as an .epcs file.

The number of defined objects and the active ones can differ for some types (e.g. Reportable objects of Event recorder). This depends on the active and inactive function blocks. All defined objects are objects belonging to all the installed function blocks. The active objects belong to only the active function blocks. In versions of EuroCAP earlier than 2.1.3.10, only the number of the defined objects and the limit was displayed for every object type. Now the number of the defined objects is in brackets and also the number of the active objects is displayed. If the active one exceeds the limit, the 'Check configuration' function indicates it as an error and the configuration can only be saved as a .epc file. Decrease the number of objects below the limit for the configuration to be saved as an .epcs file. This error is also indicated by a red (x) as shown in Figure 0-10 below.

Event recorder / Reportable objects

▲ Ix	▲ Name	▲ Title
✓ 0	Ev_Common_LLNOMod_	Mode of device
✓ 1	Ev_Common_LPHDHealth_	Health of device
✓ 2	Ev_TOV59_StL1_	Start L1
✓ 3	Ev_TOV59_StL2_	Start L2
✓ 4	Ev_TOV59_StL3_	Start L3
✓ 5	Ev_TOV59_GenSt_	General Start
✓ 6	Ev_TOV59_GenTr_	General Trip
✓ 7	Ev_TUV27_StL1_	Start L1
✓ 8	Ev_TUV27_StL2_	Start L2
✓ 9	Ev_TUV27_StL3_	Start L3
✓ 10	Ev_TUV27_GenSt_	General Start
✓ 11	Ev_TUV27_GenTr_	General Trip
✓ 12	Ev_TOV59N_GenSt_	General Start
✓ 13	Ev_TOV59N_GenTr_	General Trip
✓ 14	Ev_CTSuperV_CTFail_	CT failure

Count/Limit: 156(156)/128

active all defined limit

Figure 0-10 Count / limit in EuroCAP object lists

Uploading the configuration

Click on  for uploading the configuration. The alternative method of uploading is to select "Project / Upload to Device" from the menu. Upon clicking this button, the user is prompted to select the device into which the configuration will be uploaded. The target device can be selected from within a list of devices which are in the same LAN network. See Figure 0-11 below.

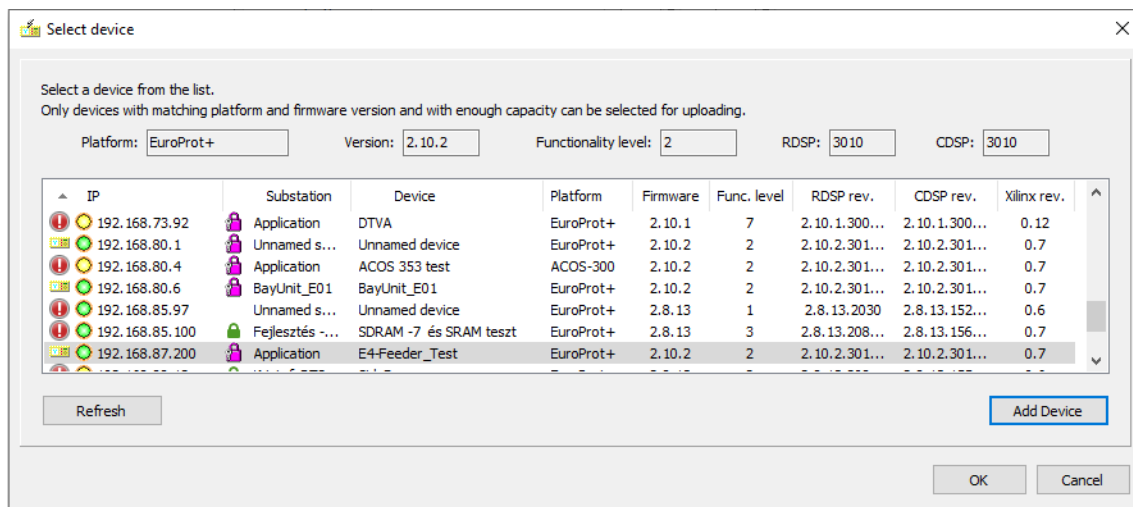







Figure 0-11 Select device window with detected devices

The exclamation sign  before the IP address means that the device has lower functionality level than the requirement of configuration (2).

Device icon  means that the user can upload the configuration to the selected device.

The LED  which is green/yellow in this example, shows the status of IED.

The green lock  marks the devices which are using the Secure FTP connection. The minimum required firmware version of this feature is CDSP 1530. The purple lock  marks the devices using HTTP/HTTPS connection. Minimum firmware requirement for this is version 2.10.1.3000. Devices without a padlock are those using FTP connection. These are devices operating on firmware versions below CDSP 1530.

If the user has to add a device manually with  button, user has to know whether the device uses the FTP, SFTP, or HTTP/HTTPS connection.

In case of manually entered device IP address, the following warning message appears:

"By uploading via entering the device IP address, the checking of the RDSP/CDSP firmware versions should be done manually."

Uploading is not allowed to a device which has a lower RDSP and/or CDSP firmware version number than the one required by the configuration file. The following error message appears in this case:

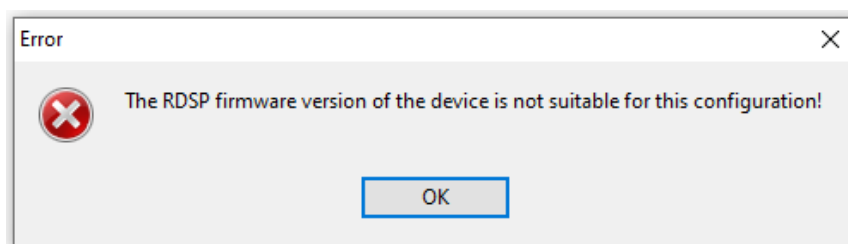

Figure 0-12 Error-message in case of higher RDSP firmware version requirement in the configuration

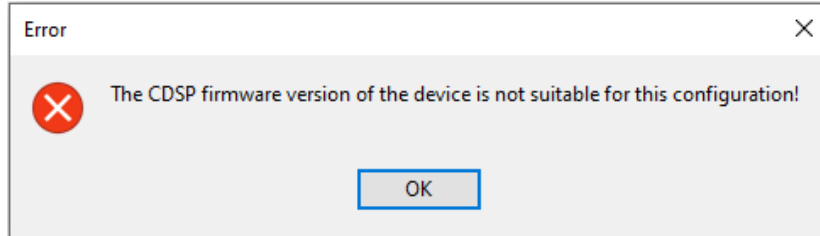

Figure 0-13 Error-message in case of higher CDSP firmware version requirement in the configuration

In other cases, the *Revision mismatch* window may appear where you can continue or cancel uploading. There is also shown which firmware does not match:

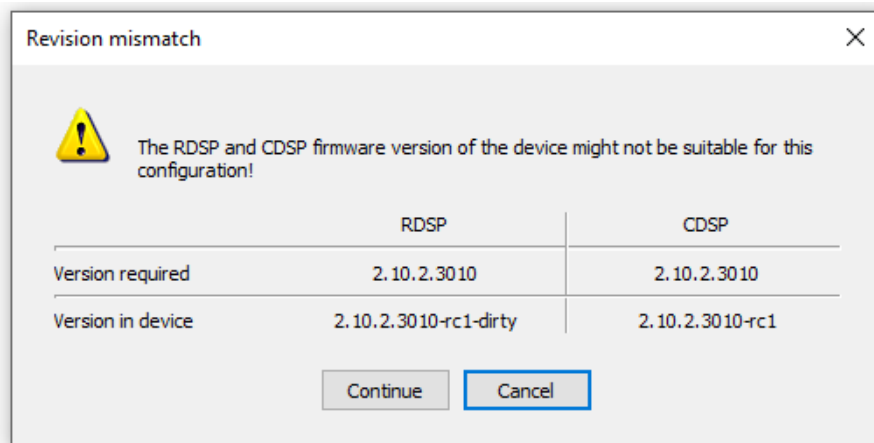

Figure 0-14 Revision mismatch window (minimum firmware requirement set for the config in EuroCAP is higher than the firmware version in the device)

Furthermore, when a fixed device firmware is required by the configuration file then a new line appears in the Revision mismatch window: *This configuration requires a fixed XXXX firmware version.*

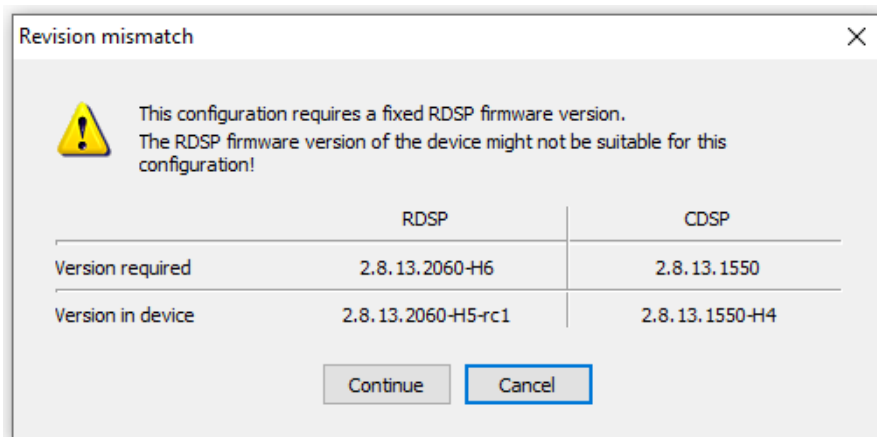

Figure 0-15 Revision mismatch window in case when fixed firmware version is required

Uploading a configuration file to a device in which role-based access control is activated prompts the user to input log-in credentials. The window shown in Figure 0-16 pops up.

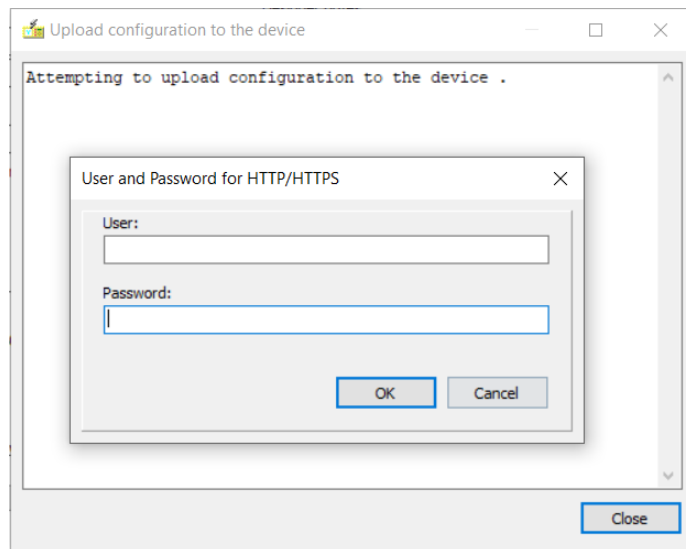

Figure 0-16 Pop-up window during configuration upload for devices with RBAC

Understanding the configuration

The operation of the EuroProt+ devices

The simplified HW and SW structure of the EuroProt+ devices are shown on Figure 0-17 below. The functions of the device operate in the hardware environment, which provides inputs and outputs for the functions. To receive the required number of analogue and binary inputs and to send the output signals to the primary equipment of the electric power system, the device is assembled of hardware modules (see hardware configuration below).

The functionality of the device is determined by the software configuration. This configuration means the assembly of functions blocks and assignment of the physical inputs to software inputs (see software configuration below).

The software consists of function blocks (e.g., overcurrent protection function, distance protection function, etc.). The "heart" of the function block consists of several "DSP functions" (e.g., Fourier component calculation, RMS value evaluation, function logic, etc.) These function blocks are described in function block description documents. They are developed, compiled and uploaded to the device by Protecta. Their correct operation is thoroughly tested by Protecta, type-tested by an accredited laboratory and can also be checked by the users.

A DSP function (performed by the dedicated Digital Signal Processor DSP) needs

- status signals,
- parameters,
- constants
- measured values.

They are stored in the "data bank" of the function block.

A DSP function generates

- binary status signals,
- events and
- measured values.

All these values are stored in the "data bank" of the function block, too.

The "data bank" of the function block is also used by the following function block elements:

- factory equations,
- internal timers,
- event channels and
- "IEC 61850 data".

The binary "results" of a function block stored as status variables can be processed by special function blocks available in all EuroProt+ configurations:

- disturbance recorder
- matrix
- graphic equation editor
- counters

The events are

- processed by the Event recorder function block.

The measured values, events, recorded disturbances and counter values can be

- sent to the supervising computer via Ethernet
- communicated by serial channels
- involved in IEC 61850 communication
- displayed on the LCD of the device (except disturbance records).

The physical outputs of the device are

- binary outputs
- Goose messages
- remote output channels
- Ethernet messages
- serial channels
- the channels of IEC 61850 communication.

HW environment

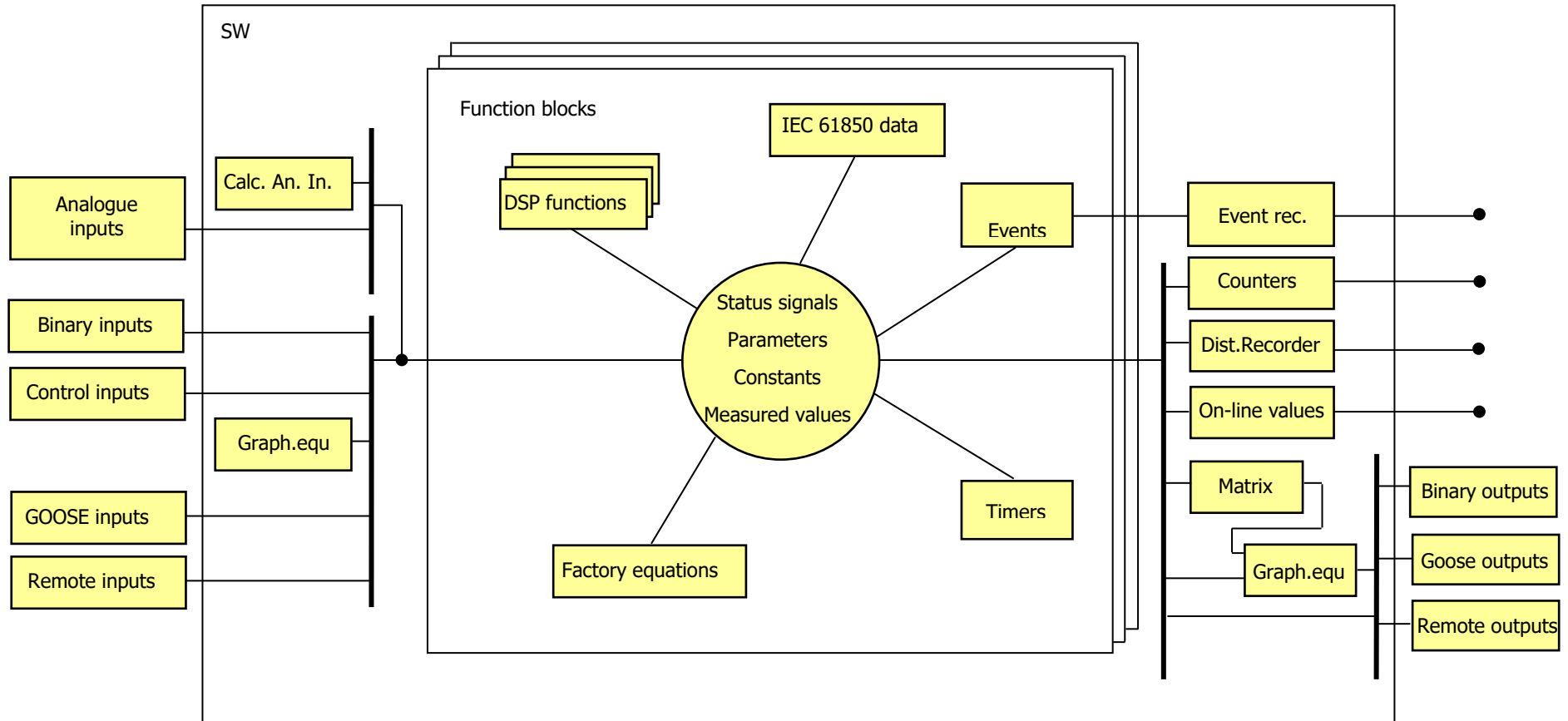

Figure 0-17 The HW and SW structure of the EuroProt+ devices

The configuration menu

The full configuration menu

The configuration menu is on the left side of the window. The displayed and active menu items depend on the mode of operation of the software (for access levels see Paragraph 0).

Figure 0-18 below shows the structure of the configuration menu as it is displayed in Master view. The > symbols indicate that the menu item can be expanded, opening sub-menus, by clicking on the > symbol.

The four main menu items are:

- Hardware configuration
- Software configuration
- Subscribed GOOSE assignment
- System

When opening any of the main menu entries, the elements of Figure 0-17 can be identified as items of the menu.

When translation is available the language can be changed in the Language menu or with the Language speed

button  on the toolbar. The object's titles will be translated to the chosen language on the following property sheets (currently only German, English and Hungarian languages are available):

- All object lists, like status variables or IO signals (in the Title column);
- Installed and Visible Function Blocks (after the colon)
- Connector Allocation (in the Name column and also in copied or printed output)
- Hardware Configuration

When the display language is not English (the default) then translated object properties (title and parameters, units, etc.) are also shown in the *Object properties* dialog window and in this window both the original (English)

and the translated value can be edited. The translation can also be changed by the  translation button.

The configuration menu in "Master view"

Figure 0-18 shows the configuration menu tree as viewed on the "Master" level. In this figure, the menu items are fully expanded. The menu items can be collapsed by clicking on the  symbol.

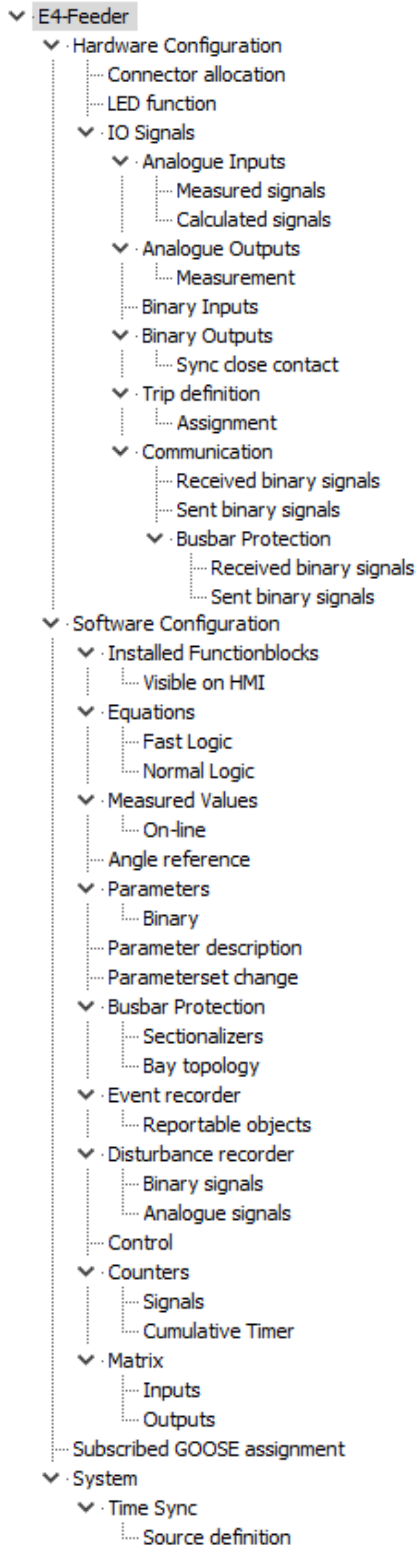

Figure 0-18 The "Master view" of the configuration menu with fully expanded menu structure

The items of the configuration menu serve the purpose of checking and modification of the active configuration. The available menu items depend on the selected "User level". Paragraph 0 and Paragraph 0 describe the menu items available in "Master" level.

Hardware configuration

The functions of the device operate in the hardware environment, which provides inputs and outputs for the functions. To receive the required number of analogue and binary inputs and to send the output signals to the primary equipment of the electric power system, the device is assembled of hardware modules.

In Master View, the hardware configuration can be displayed and extended by clicking on the "Hardware configuration" menu. The user also has the possibility to assign a Design No. which will be inserted in the configuration documentation.

The submenus of Hardware configuration are:

- Connector allocation
- LED assignment
- IO signals (with several submenus)

The Connector allocation

The details of the I/O signals can be checked in the left-side configuration menu by selecting "Connector allocation". The connectors available in the individual slots (identified by capital letters on the tabs in the bottom of the list) can be seen in this menu.

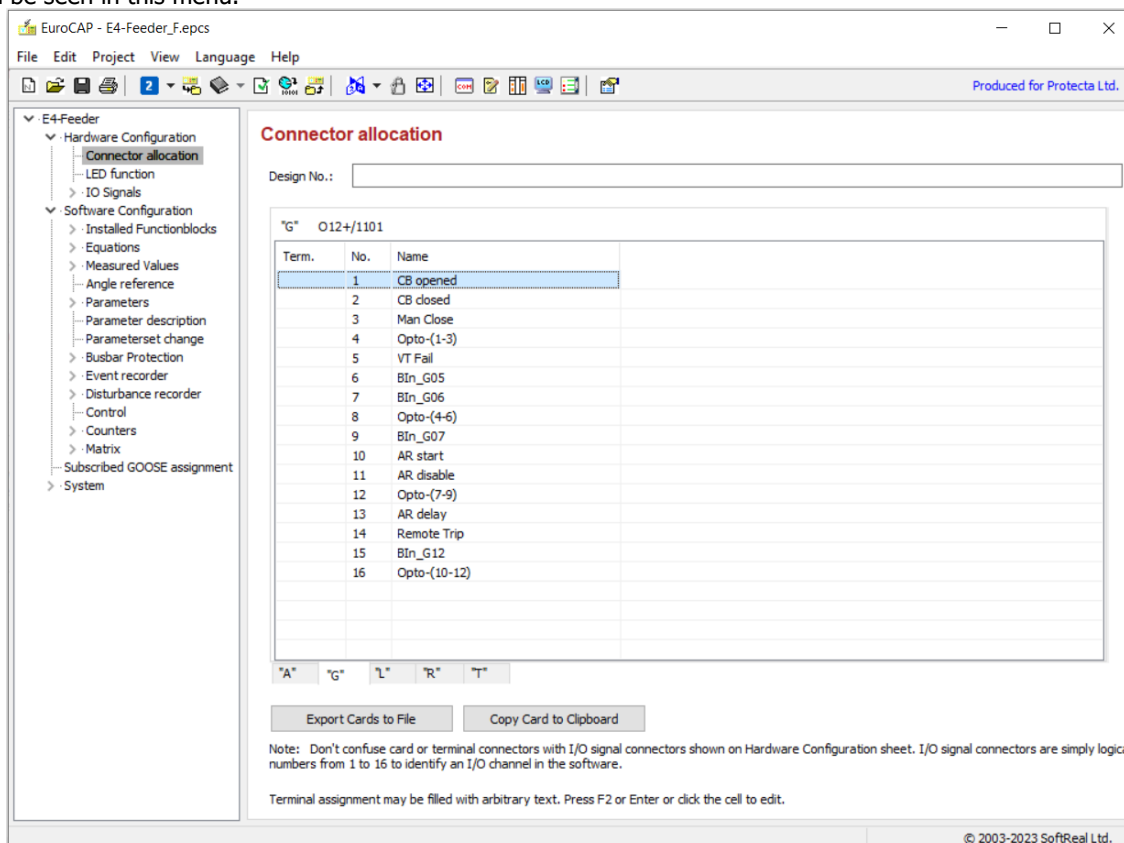
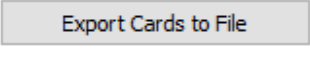

Figure 0-19 Connector allocation (Example)

Connector allocation property sheet is now fully Unicode compatible. The Terminal is shown on the beginning of the row. It may be filled with arbitrary text by user if select and press F2 or Enter. Text of terminal column will be shown in printed documentation of the configuration. (See Chapter 0)

Tabular text file can be generated pushing the  button. This is a list of all cards with numbers of terminals and connectors and signal names.

If the information of a module is needed, and then user wants to insert it into an Excel sheet,

Copy Card to Clipboard

button provide the datas of the selected module.

LED definition

The figure below shows the procedure of LED definition. In the demonstrated version LED No. 1 is on if the input variable TRC94_GenTr_GrI (General Trip) is active and it is blinking if only the input Bin_G11 is active.

Type:	0005 LED
Defined by:	RootFunctionBlock
Name:	LED3101
Title:	General Trip
Connector [1,16]:	1
GeoGrafic address [0,31]:	31
On Item name [uoz]:	0213 Graphed input Status
Blink Item name [uoz]:	TRC94_GenTr_GrI_ (General Trip)
Color [0/r,1/g,2/y] [0,2]:	0
Latch [0/n,1/y,2/e] [0,2]:	1

Figure 0-20 LED definition

LED assignment objects can be exported to and imported from an XML file.

Using the **Export** button in "LED assignment", the user can export the LED assignment settings into XML file.

It is also possible to Import these settings from XML file using **Import** button.

A report window will pop-up after the import process. This report will contain warning messages if some of the LED "On Item name"-s or the "Blink Item name"-s refer to non-existent objects. In this case these parameters are changed to "Object?". See Figure 0-21.

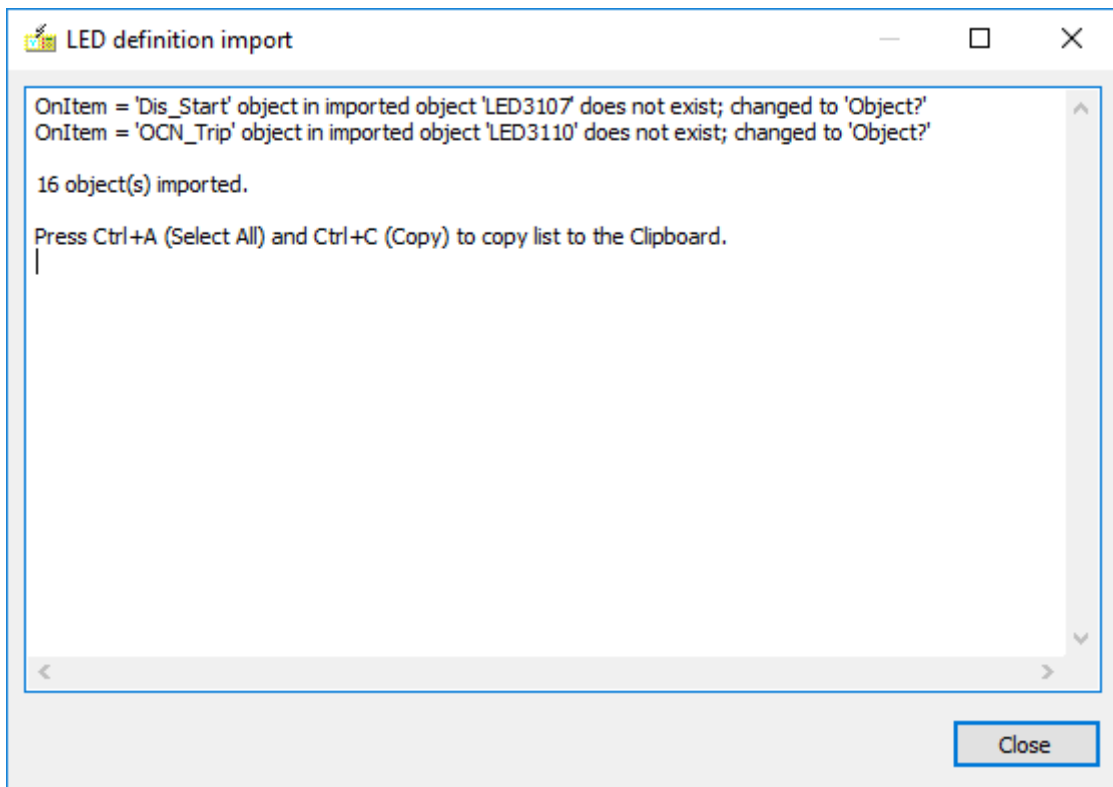

Figure 0-21 LED definition import warning message

NOTE: LED signal assignment (i.e. "On Item" & "Blink Item") is done from the graphical logic editor for higher configuration versions supported by firmware version 2.10.1.3000 and above. See Figure 0-22 and Figure 0-23 below:

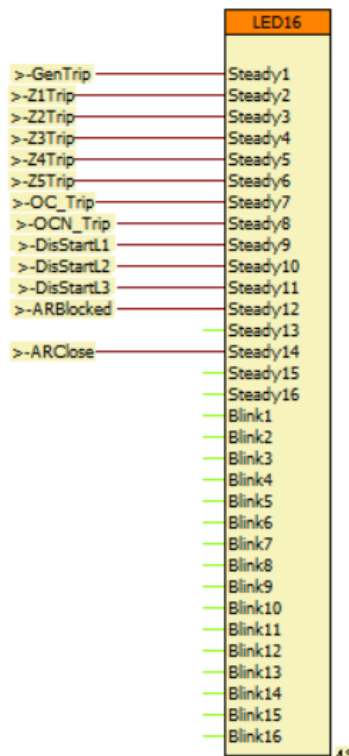



Figure 0-22 LED signal assignment in the logic editor (for higher configuration versions)

Object properties

Type:	0005 HMILED
Defined by:	RootFunctionBlock
Name:	LED3101
Title:	General Trip
Connector [1,16]:	1
Slot ID [0,31]:	31
Color [0/r,1/g,2/y] [0,2]:	0
Latch [0/n,1/y,2/e] [0,2]:	1

OK Cancel

Figure 0-23 LED definition (higher configuration versions)

When secondary language is available in the configuration file, the user can translate or change the existing translation of title with the translations  button.

For the "LED assignment" when clicking the available "Modify" button, the data input window on Figure 0-24 is opened. Here, the following modifications are allowed:

- **Title** This is a free-text field; the text will be the identifier of the LED in the documentation and when printing the LED titles. (e.g., "General Trip")
- **On Item name** Means the selection of a signal, the 1 state of which results in continuous ON state of the LED. See the selection method on Figure 0-25.
- **Blink Item name** Means the selection of an output signal, the 1 state of which results in the blinking state of the LED. See the selection method on Figure 0-25.
- **Color** Means that the color of the LED can be selected as red (r), green (g) or yellow (y) by writing 0, 1 or 2 in this input field. The On and Blink item has the same color.
- **Latch** Means that the on or blinking state of the LED can be latched until reset. The method of resetting is simply pressing the front panel button **X** below the front panel LEDs. When setting this variable to 2/e then a new event (fault) modifying the LED state will erase the previous latched state and show only the latest state.

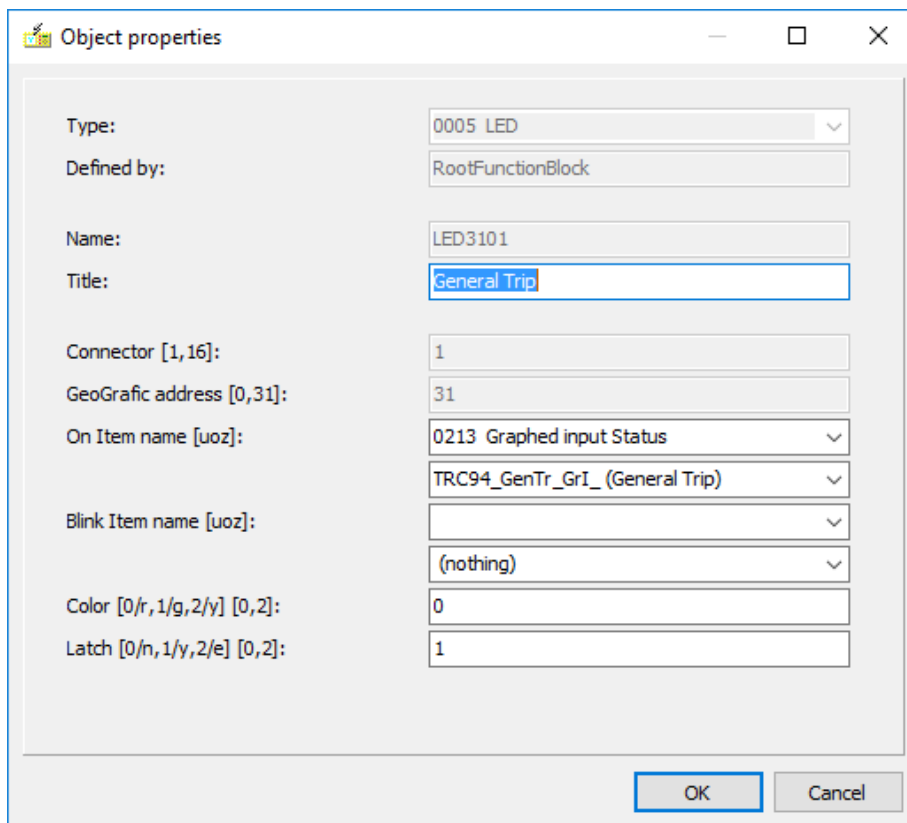

Figure 0-24 The "Object property" window for LED assignment

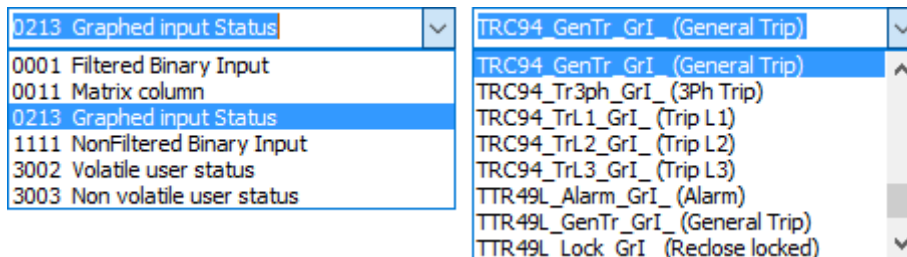

Figure 0-25 Details of the "Object property" window for fast relay contacts under On Item name.

The left side of Figure 0-25 lists the available signal types:

- *Filtered Binary Inputs* These are the signals from the binary inputs of the device. Filtering means that the transient changes within a limited time span are not considered as status changes.
- *Matrix column* These signals are the derived signals of the software matrix. For the application of the software matrix see Paragraph 0.
- *Graphed input Status* These are the binary output status signals of the function blocks. These status signals are explained in detail in the documents of the individual function blocks.
- *NonFiltered Binary Inputs* These are the signals from the binary inputs of the device. These signals are the non-filtered versions; they can reflect also the transient changes of the inputs.
- *Volatile user status* When editing the user logic in the Graphic logic editor (see the details in Chapter 0) the user may define new binary output status signals, and compose logic relationship resulting these signals.
- *Non volatile user status* When editing the user logic in the Graphic logic editor (see the details in Chapter 0) the user may define new binary output status signals, and compose logic relationship resulting these signals. These signals are defined to be stored in non-volatile memory. If the supply voltage of the device is switched off then it is switched on again, these signals preserve their logic status assigned during the previous energized state of the device.

NOTE: using the Matrix, any logic combination of the available binary signals can be assigned to the LED-s.

The IO signals

When a module is inserted in the rack using the "Rack Designer", all information is automatically stored in the data bank of the device. The individual cards have default names for the connectors; the user in "Master" level has possibility to rename these physical in- and outputs here.

The menu "IO signals" has the following items available in master view:

- (Analogue Inputs / Measured signals and Calculated signals)
- (Analogue Outputs / Measurement)
- Binary Inputs
- Binary Outputs / Sync close contact
- Trip definition / Assignment
- (Communication / Received and Sent binary signals)
- (Communication / Busbar Protection / Received and Sent binary signals)

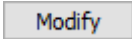
For the items in brackets, only the "Title" field may be modified when clicking on the  button; for example, the user cannot access the analogue inputs except the title; they are arranged during the factory configuration procedure.

When a secondary language is available in the configuration file, translation of I/O signal titles can be added or altered by clicking on the translations  button on the left side of the menu.

Binary inputs

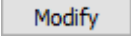
The "Binary inputs" menu contains the filtered signals. (Filtering means that the transient changes within a limited time span are not considered as status changes.) When clicking the available  button, the following modifications are allowed:

- Title This is a free-text field; the text will be the identifier of the input in the documentation and the "On-line" web page also show this title. (e.g., "CB phase L3 status")
- Rising edge delay This value is given in ms. The status change from 0 to 1 is accepted only if the initial state is 0 and during the delay time, all checking indicate status 1. (Filtering effect)
- Falling edge delay This value is given in ms. The status change from 1 to 0 is accepted only if the initial state is 1 and during the delay time all checking indicate status 0. (Filtering effect)
- Show order This value organizes the "On-line" web page sequence of displaying the binary status values. If 0 is given, the status is not displayed. All figures above 0 mean that the signals with identical figures are grouped (e.g., all signals of Show order = 2 are grouped in group No.2). The group number is not shown.

Figure 0-26 shows the list of available binary input signals in a hardware configuration.

The figure shows that the hardware module in position G provides 12 input connectors. The "Title" field is filled out according to the application. The name, the slot ID and the connector No. may not be modified. The edge delays mean the number of repeated checking before a status change is accepted. "Show order" determines the location of this status signal on the On-line screen.

Every object list is sortable by "Ix", "name", "title", "defined by" and "show order" if the user clicks on header of the proper column.

IO Signals / Binary Inputs

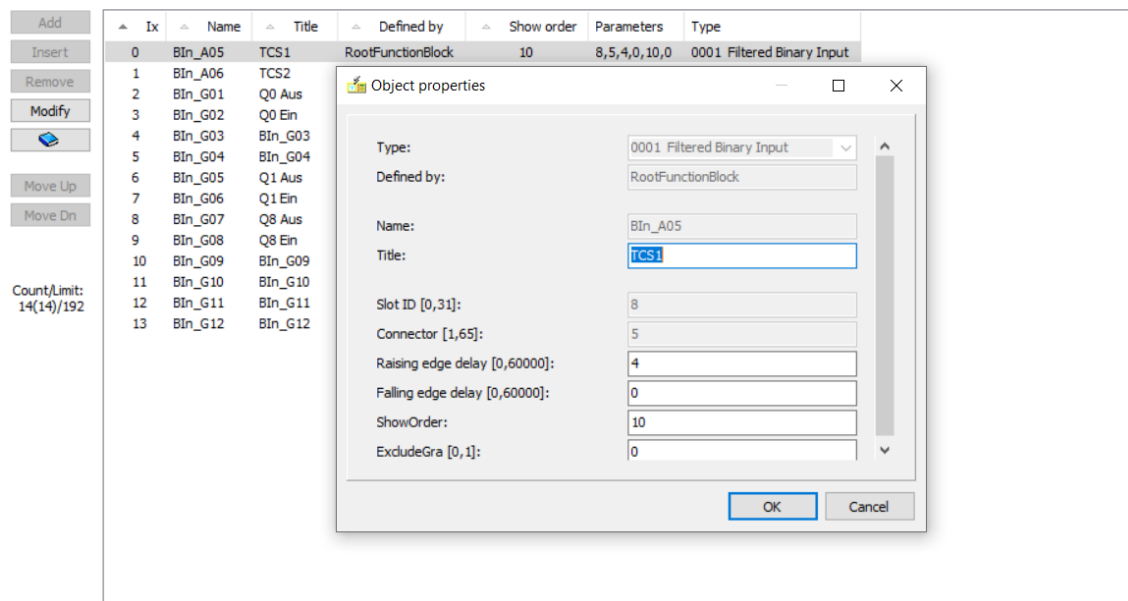

	Ix	Name	Title	Defined by	Show order	Parameters	Type
	0	BIn_A05	TCS1	RootFunctionBlock	10	8,5,4,0,10,0	0001 Filtered Binary Input
	1	BIn_A06	TCS2				
	2	BIn_G01	Q0 Aus				
	3	BIn_G02	Q0 Ein				
	4	BIn_G03	BIn_G03				
	5	BIn_G04	BIn_G04				
	6	BIn_G05	Q1 Aus				
	7	BIn_G06	Q1 Ein				
	8	BIn_G07	Q8 Aus				
	9	BIn_G08	Q8 Ein				
	10	BIn_G09	BIn_G09				
	11	BIn_G10	BIn_G10				
	12	BIn_G11	BIn_G11				
	13	BIn_G12	BIn_G12				

Count/Limit: 14(14)/192

Object properties

Type: 0001 Filtered Binary Input

Defined by: RootFunctionBlock

Name: BIn_A05

Title: TCS1

Slot ID [0,31]: 8

Connector [1,65]: 5

Raising edge delay [0,60000]: 4

Falling edge delay [0,60000]: 0

ShowOrder: 10

ExcludeGra [0, 1]: 0

OK Cancel

Note: You may not add or remove I/O signals manually. In Master View you may use Check I/O Allocations button on Hardware Configuration property sheet to match signals with hardware.

Figure 0-26 Binary input signals

The button  can be used for translation; when pressing this button, a new window shows the available languages:

Binary outputs

Figure 0-27 shows the list of available binary output signals in a hardware configuration.

IO Signals / Binary Outputs

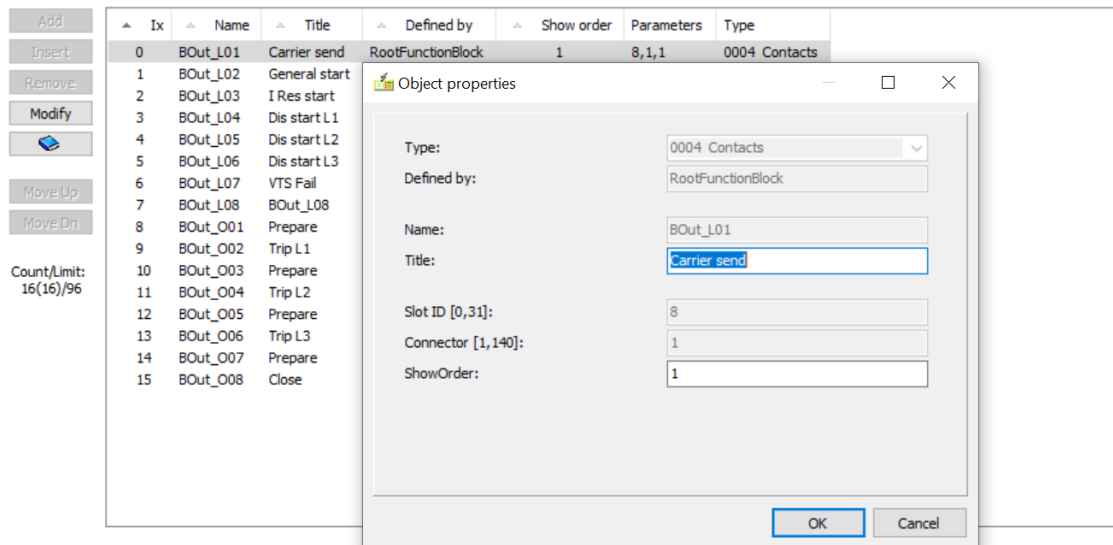

Note: You may not add or remove I/O signals manually. In Master View you may use Check I/O Allocations button on Hardware Configuration property sheet to match signals with hardware.

Figure 0-27 Binary output signals

It can be seen that the hardware module in position "L" provides 8 output connectors for signalling and in position "O" 4 output connectors for tripping. Tripping module "O" is characterized by the Prepare Titles. The rest of the Titles are filled out according to the intended application.

For "Binary Outputs" clicking the available **Modify** button, the following modifications are allowed:

- **Title** This is a free-text field; the text will be the identifier of the output in the documentation and the "On-line" web page also show this title. (e.g., "Carrier send")
- **Show order** This value organizes the "On-line" web page sequence of displaying the binary status values. If 0 is given, the status is not displayed. All figures above 0 mean that the signals with identical figures are grouped (e.g., all signals of Show order = 2 are grouped in group No.2).

The "Sync close contact" submenu provides fast relay operation for the user. In this case, the driving signal does not need to wait for the relatively slow processing of the logic equations available for the users; the selected relays get the status of the assigned signal in every millisecond.

If fast closing (without delay, within 1 ms) is needed, then this kind of contact operation is to be prescribed by clicking the

- "Add",
 - "Insert"
 - "Modify"
- active buttons. In this case, the data input window shown in Figure 0-28 is opened.

Here the

- "Title" can be renamed. This is a free-text field.
- "Contact" a selection from the dropdown menu. E.g.:
- "0004 Contacts" the only choice here
- "BOut_008 (Close)" is a contact selected from the second dropdown menu
- "On Item name" identifies the binary signal to operate the relay. Any internal signal can be selected from the dropdown menu. The user must select these signals first by the signal type according to (Figure 0-25 left side) then the selected signal itself (Figure 0-25 right side).

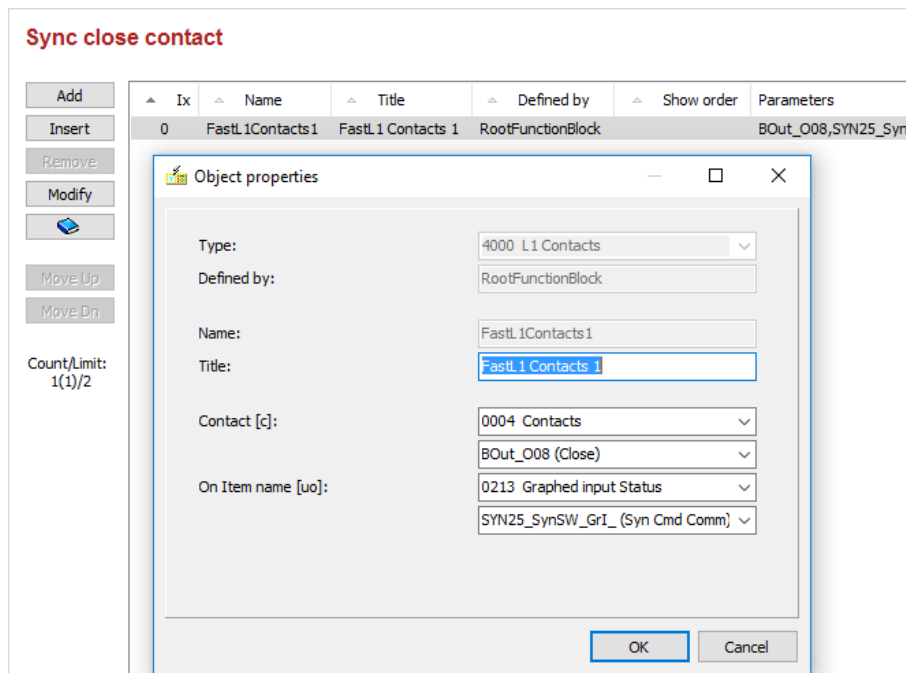

Figure 0-28 Assignment of the Sync Close contacts

Figure 0-28 shows that the Bout_008 (Close) contact gets the status of the SYN25_SynSW_GrI_ (SynchroSwitch Close) in every millisecond. The selection of both the output contact and the driving signal is supported by dropdown menus.

Trip definition

The contacts of TRIP module are special. These are selected to operate very fast. If fast tripping (without delay, within 1 ms) is needed using e.g. Distance / Differential protection function, then this kind of contact operation is to be prescribed by clicking the

- "Add",
 - "Insert"
 - "Remove" or
 - "Modify"
- active buttons. In this case, the data input window shown in Figure 0-29 is opened.

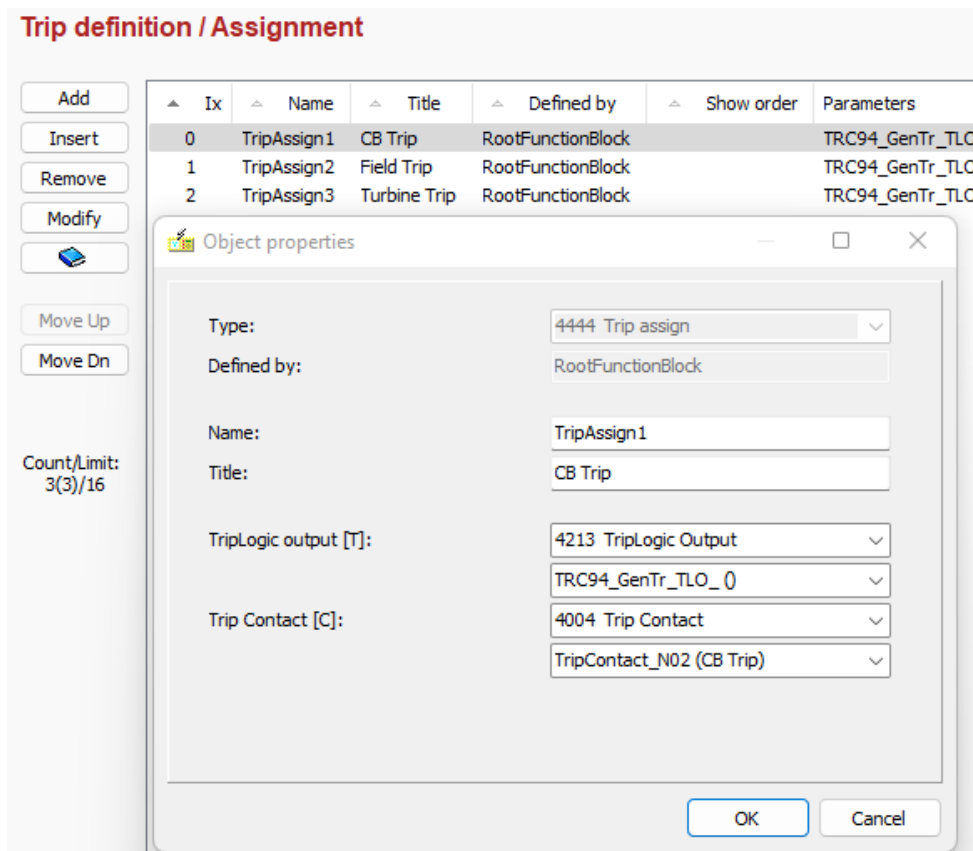

Figure 0-29 The "Object property" window for Trip definition / Assignment

Here the

- "Title" is a free-text field; the text will be the identifier of the output in the documentation.
- "TripLogic output" is a selection from the dropdown menu pre-defined by Protecta Ltd, E.g.:
 - "4213 TripLogic Output" type the only choice here
 - "TRC94_GenTr_TLO_()" is the Trip logic output selected from the second dropdown menu
- Protection functions can be assigned to a Trip logic block (e.g. TRC94) by means of a graphical logic or with fast equations. Assignment information can be found in the graphical logic editor.
- "Trip contact" identifies the trip relay to operate. A reduced/restricted list of Trip contacts is provided by Protecta Ltd. to select the desired output from the dropdown menu.

NOTE: for application of the trip contacts of the device see also the detailed document: "[Application of high-speed TRIP contacts](#)".

Communication

The master user can modify only the title of the following items:

- The "Received binary signals" and "Sent binary signals" submenus show the received / sent signals from one end to the other end via e.g. a fiber optic cable using the line differential function.
- Signals of busbar protection communication between the "central-unit" and the "bay-unit" are shown in the Busbar protection / "Received binary signals" and "Sent binary signals" submenus.

Software configuration

The functionality of the device is determined by the software configuration. This configuration means the assembly of functions blocks for the device and assignment of physical inputs to software inputs (see software configuration below).

The software consists of function blocks (e.g., overcurrent protection function, distance protection function, etc.). Protecta installs the function blocks during the factory configuration process. In "Master view" the user has the possibility to deactivate/activate the various function blocks. For a deactivated block, no parameter setting is needed and no output signals are generated.

Functions

Installed function blocks

Figure 0-30 shows a possible configuration when opening the "Software configuration/ /Installed Functionblocks" menu. The green checkmarks indicate active blocks, the red X means that the function block is not needed and it is deactivated. The grayed checkmark means that the operation of the function block cannot be deactivated because it is not allowed or it is used in a logic editor sheet.

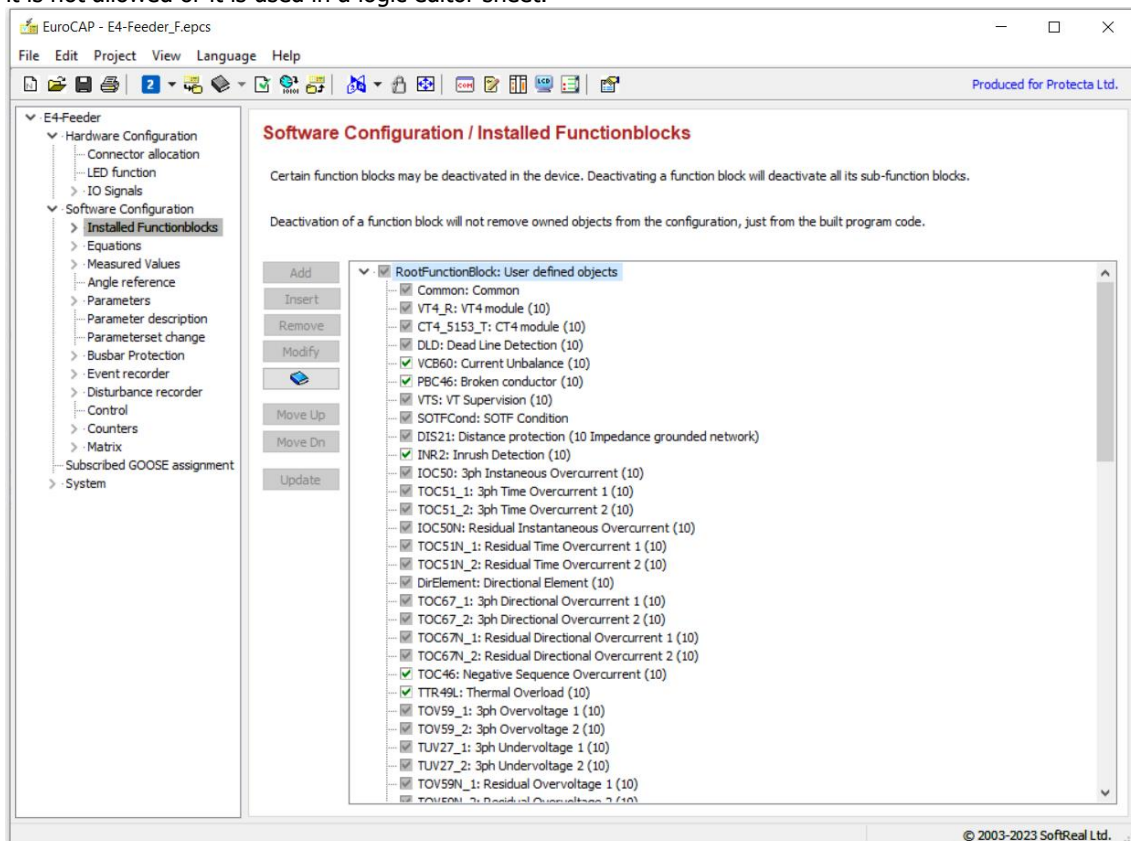



Figure 0-30 The "Function Blocks" window in software configuration

Activation/ deactivation of function blocks

If the checkbox is not grey, the user can activate or deactivate the functions blocks simply by clicking on the checkmark field.



WARNING: Be careful when deactivating functions! To check for errors, apply the  icon, which will start the "Check Configuration" procedure. The alternative method of checking is to select "Project / Check configuration" from the menu. The result is acceptable, if the summary of the check is similar to Figure 0-31: No errors found.

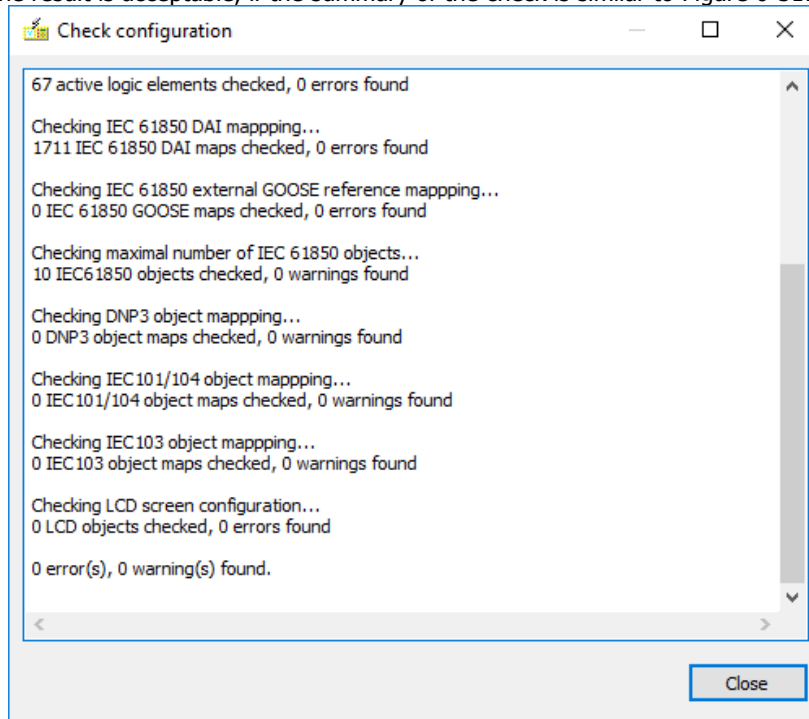



Figure 0-31 The result of "Check Configuration"

In Master level the Title of the function block may be modified. In addition, by clicking on the  Translation button, the translation of the title can be modified. (See Figure 0-32)

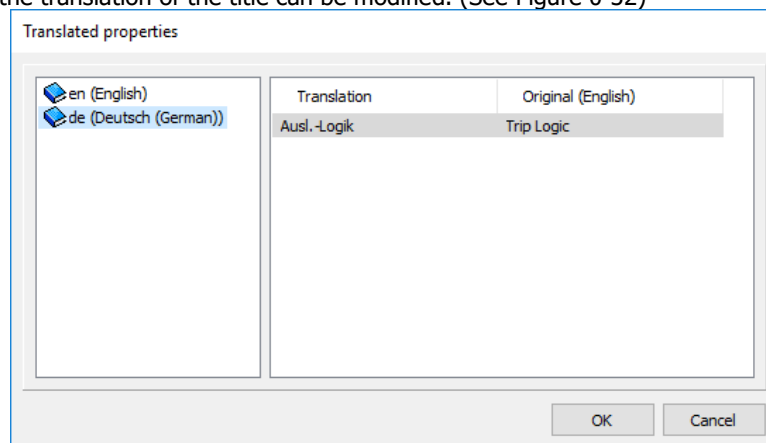
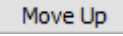
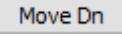

Figure 0-32 Translation

Selected Function Block can be moved up  and down  in the Installed FBs list in Master View. The display order of the function blocks on the web page of the IED can be modified by this feature.

Modification of function blocks

In some exceptional cases, the user can perform some modifications in the function blocks in "Master view". When the "Modify" active button is clicked, the function block properties are shown in a pop-up window shown in Figure 0-33.

Software Configuration / Installed Functionblocks

Certain function blocks may be deactivated in the device. Deactivating a function block will deactivate all its sub-function blocks.
Deactivation of a function block will not remove owned objects from the configuration, just from the built program code.

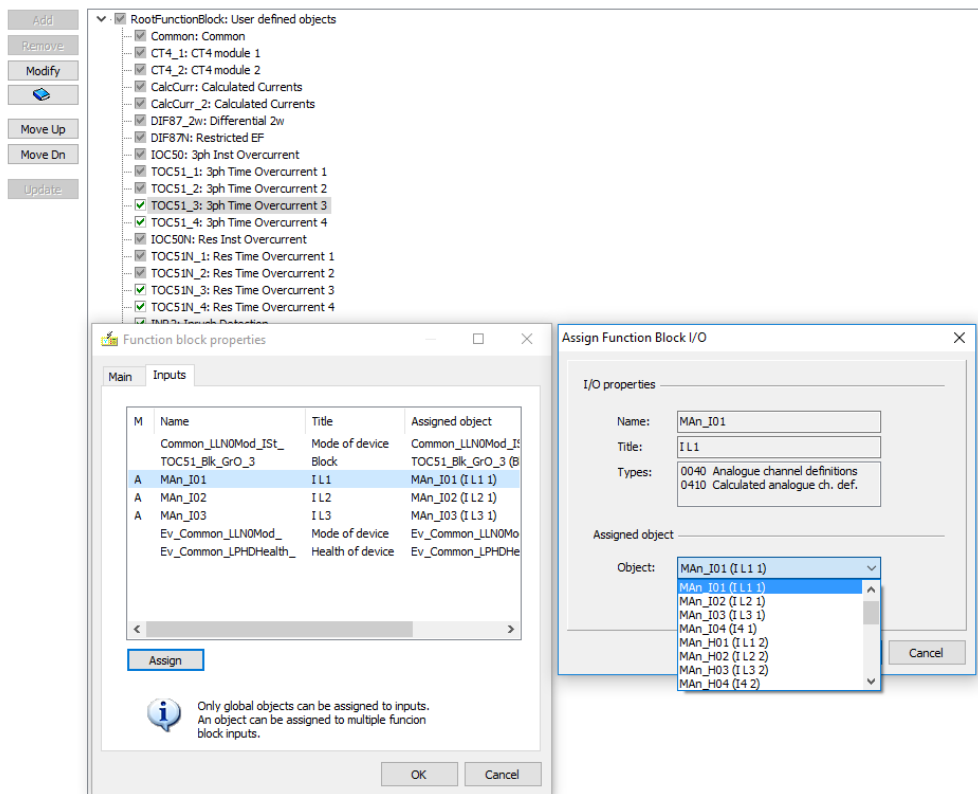

Figure 0-33 The "Function block properties" window

As an example, this window shows the procedure of assigning inputs to a definite time overcurrent protection function (TOC51D).

The "A" in the "M" shows that the input can be reassigned by the general user and not just the factory user (the designation with letter "A" may vary in different languages, like "Z" in German language).

When the active "Assign" button is clicked, the "Assign Function Block I/O" window is opened. In our example an assignment was selected (the name "Man_I01(IL1 1)" in this factory configuration).

Function blocks also have a version number. The version is displayed in the Function Block Properties "Main" window. Only an Administrator can modify the version number. The general user can however modify the title and set up groups for mutually exclusive function blocks (Figure 0-34). If multiple FB's are assigned to the same group, only one of them can be activated at a time. Time critical functions (e.g. differential, inst. OC) are part of the fast equations and therefore cannot be assigned to a group of mutually exclusive function blocks.

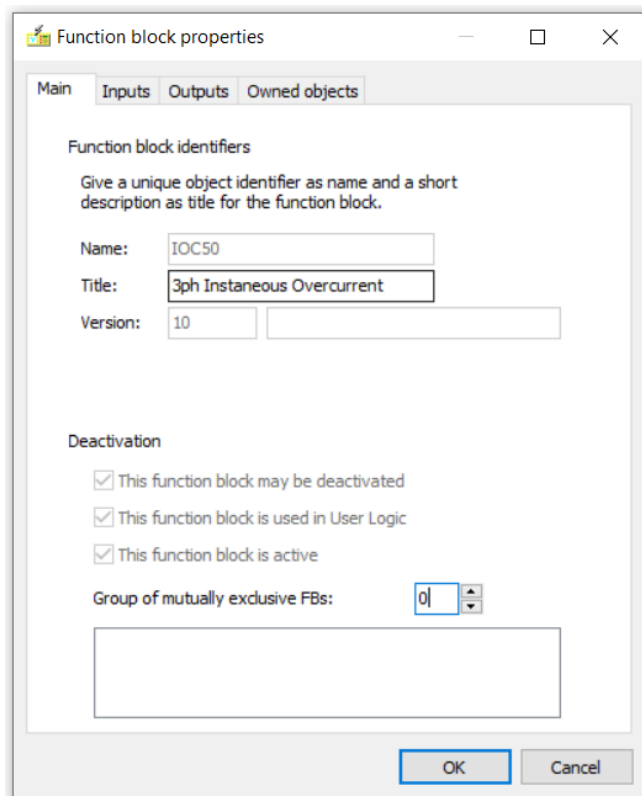

Figure 0-34 The "Main" window of FB properties

In most cases, however, the user has no access to the function block and the modification is permitted on higher access level (e.g.: administrator view) only.

Visible on HMI

The function block list in "Visible on HMI" submenu contains only the active function blocks which are not deactivated in the Installed function blocks list. Core Function Blocks -which cannot be deactivated, because they are used in the Logic editor or the deactivation is forbidden- are shown with grey checkbox in the Visible function blocks list.

If some of the function blocks are not needed, they can be set to "invisible" status here. The invisible function blocks do not show the parameters and do not change status signals and the measured variables. Hiding a core function block requires confirmation.

To set a function block invisible, enter the "Software configuration / Functions / Visible function block" menu and toggle the "Visible" status from green check mark to red X.

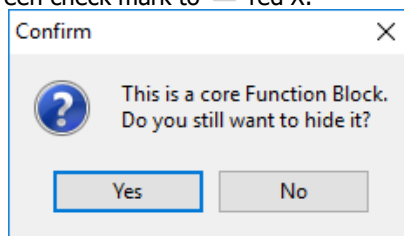

Figure 0-35 Confirmation question

Equations

Master users can see the equations applied for the different protection functions for information. Changes are not allowed on this access level.

NOTE: The content of these Equations is not visible in the graphical logic editor.

Fast Logic

Fast Logic equations are used to create a fast channel for time sensitive functions (e.g.: 87 trip, 21 trip, 50 trip or 25 synch switch command) to activate the relay high-speed outputs. The equations assign the time sensitive signals to functions (TRC94, SYN25_SynSW), which can directly operate the high-speed output contacts. Contact assignment to these functions shall be done under HW Configuration / IO Signals / Binary Outputs & Trip definition.

Normal Logic

Normal Logic equations are used to supplement FB functionalities and implement special functions requested by the customer. They shall be used for non-time sensitive signals only.

Measured values

The "Software configuration /Measured Values" menu has a submenu "On-line". All measured values are listed here, which are visible under "On-line data" on the web browser. The "Title" field can be modified only.

Parameters

NOTE: The parameter setting is basically not a task for this EuroCAP configuration software. Only the Binary parameter type can be managed under "Software configuration /Parameters" menu (see Figure 0-18.)

All other necessary parameters are part of the factory configuration; the user has no access to them. (Timer parameters are exceptions: when a user defines a new timer in the Logic editor then also a new timer can be defined. This new timer may be modified in the Logic editor.)

When opening the "**Binary parameters**" menu, Figure 0-36 is displayed. Only the user defined parameters are shown here. These new parameter values must be set in the device, and the parameters can be applied when editing the graphical equations. (See Chapter 0)

If no parameter has been defined yet, then the active "Add" button can be clicked and the "Object properties" window is also opened (see Figure 0-36). The same window is displayed when several user defined parameters exist and the button "Insert" or "Modify" is clicked. The "Remove" button is also active for the user defined binary parameters.

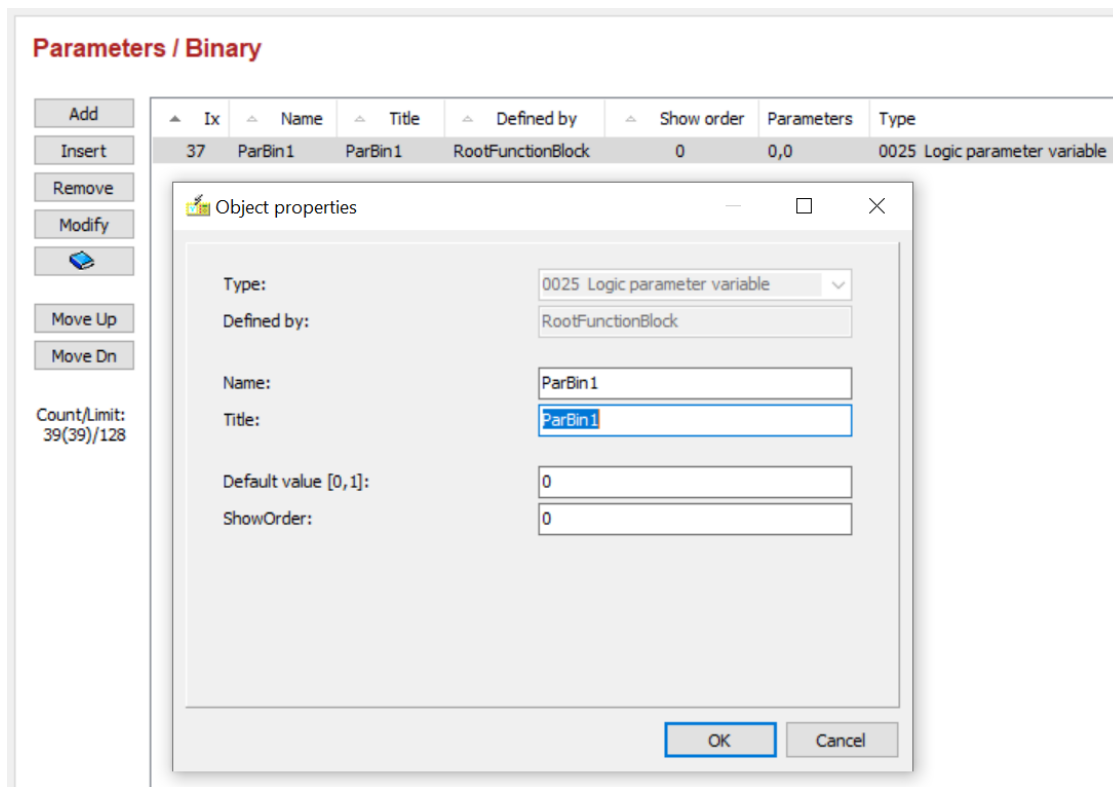

Figure 0-36 The "Binary parameters" window and the "Object properties" data block

When adding a new binary parameter, the following must be defined:

- Name the freely editable name of the new parameter displayed in the graphical editor
- Title the freely editable title of the new parameter displayed in the graphical editor (in brackets)
- Default value the value without parameter modification
- ShowOrder this value organizes the "Parameter" sequence of displaying the parameter values. If 0 is given, the status is not displayed. All figures above 0 mean that the signals with identical figures are grouped (e.g., all signals of Show order = 2 are grouped in group No.2).

Parameter description

If the Title of the parameter gives less information than it is necessary, a parameter description can be created. This description will be shown on the "parameters" web page of the IED. Required CDSP version is 1530 or above.

When adding a new parameter description, the following must be defined:

- Name the freely editable name of the new parameter displayed in the graphical editor
- Title the freely editable title of the new parameter displayed in the graphical editor (in brackets)
- Referred object the object is selectable from a list contains Integer, Timer, Logic, Constant, Float, Enumerated and User timer parameters
- Text the freely editable text provides users to get detailed information about the parameter or make note e.g. a suggested setting value.

In case of any error message received during modifying or creating parameter description, the configuration file shall be updated by Protecta staff.

Parameterset change

When opening the "**Parameterset change**" menu, Figure 0-37 is displayed. In this example, a new parameter set is to be added. The ParSet1 is active if the "Bin_G02" binary input receives an active signal. In the example, a new set is "Add"-ed, and the "Bin_G02" binary input is prepared for selection to activate that set.

ATTENTION: The number of parameter sets is defined by the number of the parameter sets added plus the original one. If any condition for parameter set changes is set in the "Parameter set change" window, then this operation cannot be performed in any other way. If the "Condition" input field is empty, the command via IEC 61850 communication channel or via web browser can change between the available parameter sets.



If no new parameter set has been defined yet, then the active "Add" button can be clicked and the "Object properties" window is also opened (see Figure 0-37). The same window is displayed when several defined parameters exist and the button "Insert" or "Modify" is clicked. The "Remove" button is also active.

Software Configuration / Parameterset change

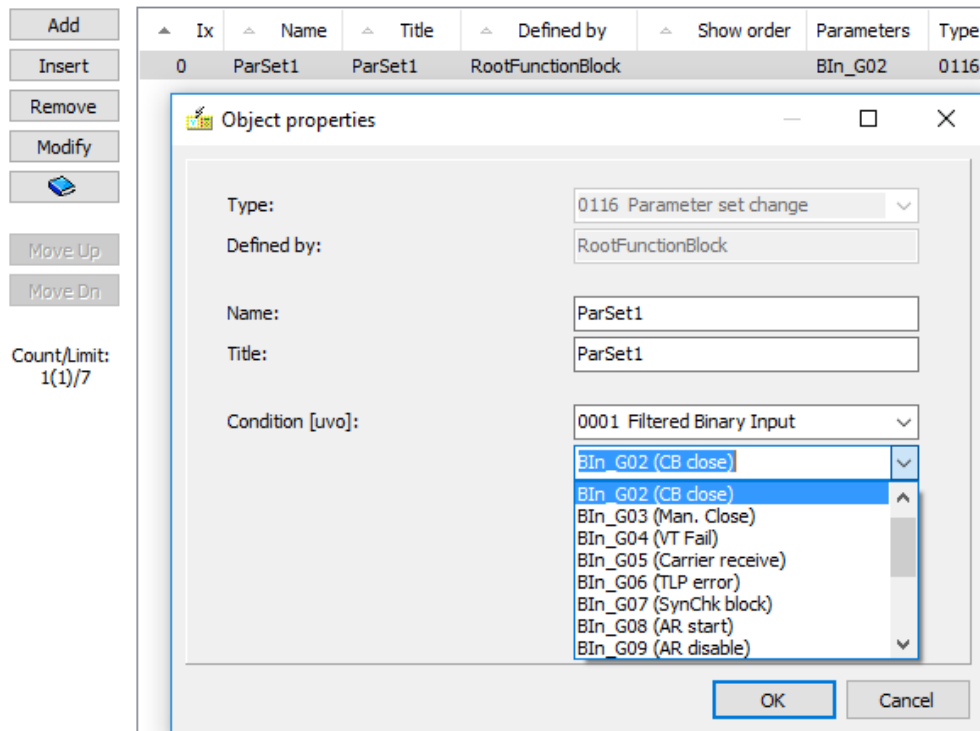

Figure 0-37 The "Parameterset change" window and the "Object properties" data block

Busbar protection

A factory default primary topology is set in all central unit of a distributed or a centralized busbar protection device. The user can modify this pre-configured topology, using the following types.

The object lists are sortable by "Ix", "name", "title", "defined by" and "show order" if the user clicks on header of the proper column. Note: "Ix" of an object is the creation order by default, but it can be modified for some type of objects by the "Move up" and "Move down" buttons (like for disturbance recorder signals, matrix inputs and outputs), because this number means also the displaying order for those object types.

Sectionalizers

The sectionalizer can combine zones when you have disconnectors in the sectionalizer bay without current transformer. If no sectionalizer has been defined yet, then the active "Add" button can be clicked and the "Object properties" window is also opened (see Figure 0-38).

User can choose a Disconnector closed status which combines the selected Bus Sections (Zones). A Master View user can not add new Bus Section function blocks into the configuration. Busbar protection algorithm can handle maximum 10 pieces of Sectionalizers.

Busbar Protection / Sectionalizers

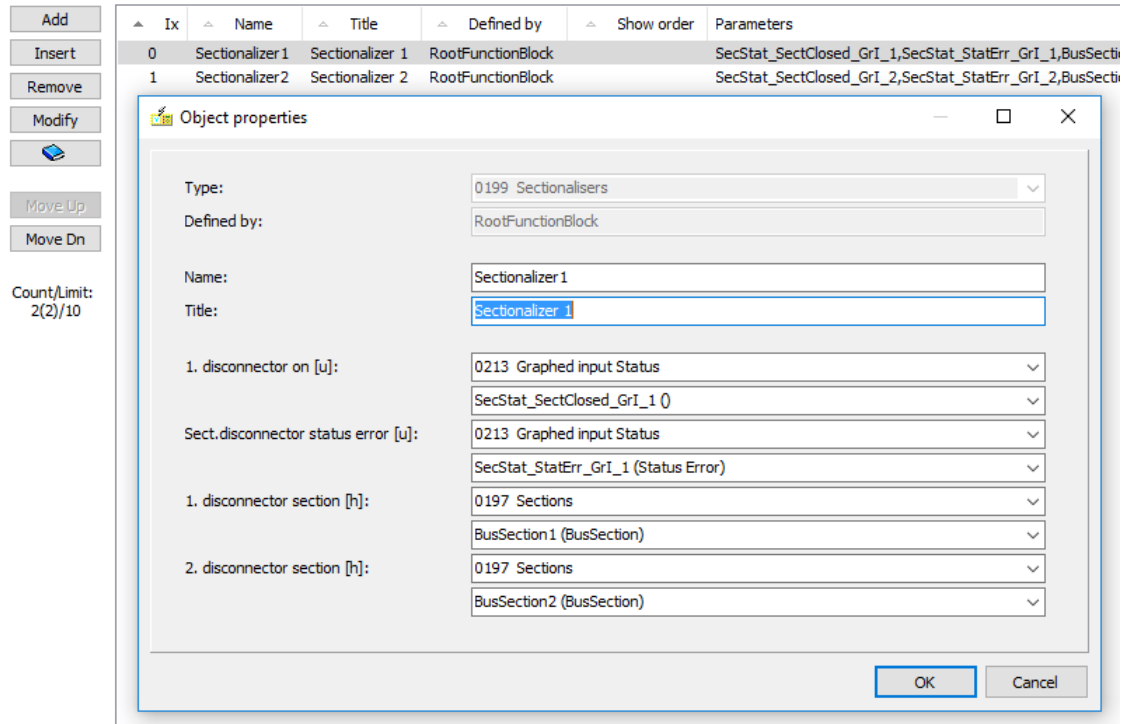

Figure 0-38 The "Sectionalizers" window and the "Object properties" data block

Bay topology

The bay topology handles all bays where current transformer(s) is available. Incomer or feeder bays, bus coupler bays with one or two current transformer(s) and some special bays.

If no bay unit has been defined yet, then the active "Add" button can be clicked and the "Object properties" window is also opened (see Figure 0-39).

All fields can be modified by the user. The maximum bay element number is 36.

For some examples and detailed information please visit our webpage and find the detailed description of "Centralized busbar differential and breaker failure protection function" or "Distributed busbar differential and breaker failure protection function"

Busbar Protection / Bay topology

The screenshot shows a software interface for configuring busbar protection. On the left, there are buttons for 'Add', 'Insert', 'Remove', 'Modify', and 'Move Up/Dn'. A table lists two bay objects: Bay01 and Bay02, both defined by 'RootFunctionBlock'. An 'Object properties' dialog box is open for 'Bay01', showing its configuration details.

▲	Ix	▲	Name	▲	Title	▲	Defined by	▲	Show order	Parameters
	0		Bay01		Bay01		RootFunctionBlock			BayUnit_BU_BBU_E01,BusSection1,,,,1,0,0,0
	1		Bay02		Bay02		RootFunctionBlock			BayUnit_BU_BBU_E02,BusSection2,,,,1,0,0,0

Object properties

Type: 0200 Bay topology
 Defined by: RootFunctionBlock
 Name: Bay01
 Title: Bay01
 Assigned bay []: 0198 Bay units
 BayUnit_BU_BBU_E01 (Bay Unit)
 1. disconnecter section [h]: 0197 Sections
 BusSection1 (BusSection)
 2. disconnecter section [h]: (nothing)
 3. disconnecter section [h]: (nothing)
 4. disconnecter section [h]: (nothing)
 Include to check zone [0,1]: 1
 CT Dir.Inverted [0,1]: 0
 Connection ref.No. [0,255]: 0
 Conn.Ref.Condition [0,1]: 0

Figure 0-39 The "Bay topology" window and the "Object properties" data block

Events

The EuroProt+ protection devices log the events with a time stamp of 1 ms time resolution. The list of the possible events is populated in the factory configuration procedure; the user has possibility to modify the "Title", the text identifier of the event. This Title is shown in the event list.

NOTE: User-defined events shall be set up by applying the GGIO16 function blocks in the Logic Editor, then editing its events' titles here. Up to 16 events can be generated per function block.

The object lists are sortable by "Ix", "name", "title", "defined by" and "show order" if the user clicks on header of the proper column. Note: "Ix" of an object is the creation order by default, but it can be modified for some type of objects by the "Move up" and "Move down" buttons (like for disturbance recorder signals, matrix inputs and outputs), because this number means also the displaying order for those object types.

The IEC 61850 DOI description column shows the first non-empty description of the mapped Data Objects (the owners of the mapped Data Attributes).

Event recorder / Reportable objects

	▲	▲	▲	▲	▲				
	Ix	Name	Title	Defined by	Event list	Parameters	Type	IEC101/104	IEC61850 DOI description
	100	GGIO16_stVal01_	Input01	GGIO16	1	GGIO16_stVal01_GrO_1	0009 ...	0	Man. Close
	101	GGIO16_stVal02_	Input02	GGIO16	1	GGIO16_stVal02_GrO_1	0009 ...	0	VT Fail
	102	GGIO16_stVal03_	Input03	GGIO16	1	GGIO16_stVal03_GrO_1	0009 ...	0	TLP error
	103	GGIO16_stVal04_	Input04	GGIO16	1	GGIO16_stVal04_GrO_1	0009 ...	0	SynChk block
	104	GGIO16_stVal05_	Input05	GGIO16	1	GGIO16_stVal05_GrO_1	0009 ...	0	AR start
	105	GGIO16_stVal06_	Input06	GGIO16	1	GGIO16_stVal06_GrO_1	0009 ...	0	Remote Trip
	106	GGIO16_stVal07_	Input07	GGIO16	1	GGIO16_stVal07_GrO_1	0009 ...	0	PSD Block
	107	GGIO16_stVal08_	Input08	GGIO16	1	GGIO16_stVal08_GrO_1	0009 ...	0	
	108	GGIO16_stVal09_	Input09	GGIO16	1	GGIO16_stVal09_GrO_1	0009 ...	0	
	109	GGIO16_stVal10_	Input10	GGIO16	1	GGIO16_stVal10_GrO_1	0009 ...	0	
	110	GGIO16_stVal11_	Input11	GGIO16	1	GGIO16_stVal11_GrO_1	0009 ...	0	
	111	GGIO16_stVal12_	Input12	GGIO16	1	GGIO16_stVal12_GrO_1	0009 ...	0	
	112	GGIO16_stVal13_	Input13	GGIO16	1	GGIO16_stVal13_GrO_1	0009 ...	0	

Count/Limit:
176(176)/512

Figure 0-40 The Event channels with IEC 61850 DOI description column

The button copies the content of the *IEC 61850 DOI description* column to the *Title* column for all selected lines. When the current language is English then the original value, otherwise the translated value of the object's title will be modified. Please select lines carefully because the titles will be overwritten without confirmation. This feature is useful because the *IEC 61850 DOI description* field can be filled already in the Logic editor where the connections of e.g. a GGIO16 defined.

The list on the *IEC 61850 Logical Nodes* property sheet is sorted by the owner Function Blocks (the *Defined by* column). The contents of the ICD / CID files are not affected.

When a language other than English is selected, you can still modify the original (English) title and translatable parameters together with their translations in the *Object properties* window. The translation button appears next to a translation.

Figure 0-41 Translation possibility in the Object properties window

Disturbance recorder

The disturbance recorder function records binary and analogue signals; these signals can be selected (and modified) by the user.

Selecting a binary signal for disturbance recording

Figure 0-42 shows the selection method of binary signals. The user can define

- Name the freely editable name of the signal
- Title the freely editable title of the signal
- Item name the item to be recorded

The item selection method is similar to the method encountered elsewhere in the EuroCAP software: First, the type of the signal must be selected from the drop-down list (in this case, "Graphed input Status," which is an output signal of the function block BRF50). The second step is the selection from another drop-down list displaying all signals of the selected type. (Here, BRF50_BuTr_GrI_(Backup Trip), which is the backup trip signal of breaker failure protection function.)

Object properties

Type: 0097 Dist.rec. digit signals (max64) ▾

Defined by: RootFunctionBlock

Name: DRBin13

Title: Backup Trip

Item name [uocz]: 0213 Graphed input Status ▾
BRF50_BuTr_GrI_ (Backup Trip) ▾

OK Cancel

Figure 0-42 Example: selecting the binary signal for disturbance recording

The available binary signal types for the disturbance recording (Item name) are:

- *Filtered Binary Inputs* These are the signals from the binary inputs of the device. Filtering means that the transient changes within a limited time span are not considered as status changes.
- *Contacts* The binary status of the output contacts
- *Graphed input Status* These are the binary output status signals of the function blocks. These status signals are explained in detail in the documents of the individual function blocks.
- *NonFiltered Binary Inputs* These are the signals from the binary inputs of the device. These signals are the non-filtered versions; they can reflect also the transient changes of the inputs.
- *Volatile user status* When editing the user logic in the Graphic logic editor (see the details in Chapter 0) the user may define new binary output status signals, and compose logic relationship resulting these signals.
- *Non-volatile user status* When editing the user logic in the Graphic logic editor (see the details in Chapter 0) the user may define new binary output status signals, and compose logic relationship resulting these signals. These signals are defined to be stored in non-volatile memory. If the supply voltage of the device is switched off then it is switched on again, these signals preserve their logic status assigned during the previous energized state of the device.

Selecting an analogue signal for disturbance recording

Figure 0-43 shows the selection method of analogue signals.

The user can define

- Name the freely editable name of the signal
- Title the freely editable title of the signal
- Item name the item to be recorded
- Nominal value the nominal value of the signal
- Unit the unit of measure.

The item selection method is similar to the method encountered elsewhere in the EuroCAP software:

First, the type of the signal must be selected from the drop-down list (in this case, "Analogue channel definitions" is selected, which is an input analogue value). The second step is the selection from another drop-down list displaying all signals of the selected type. (Here, Man_R01(U L1), which is the first voltage input signal, e.g., the L1 phase voltage connected to the R01(U L1) input.)

Nominal value and unit can be 100% as in the factory default configurations. Furthermore, primary or secondary values can also be set, so 1A or 5A sec. or e.g.1000A prim. are possible. The COMTRADE file will show these values.

Scaling for VT secondary other than 100V: E.g. when the VT has 110VAC secondary nominal and we want to show it as a percentage, the nominal value of analogue channel has to be 91%, to compensate the 110V nominal.

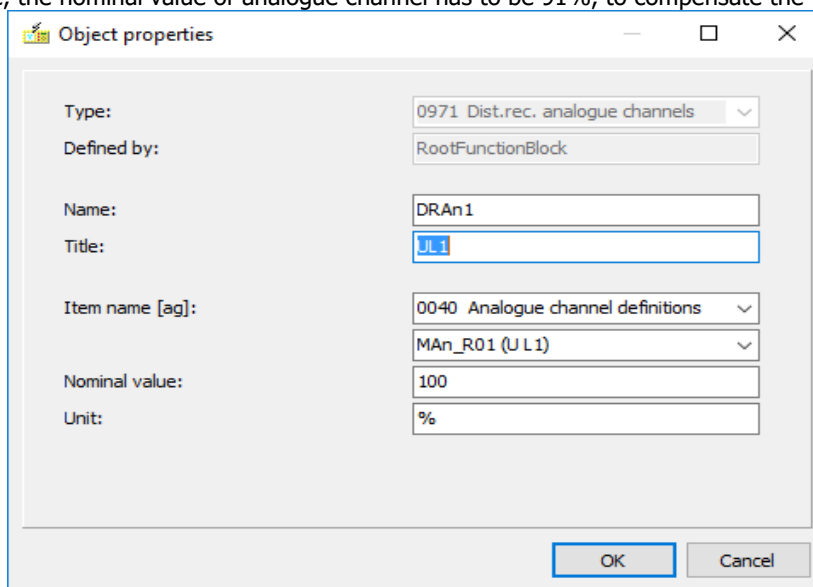

Figure 0-43 Example: selecting the analogue signal for disturbance recording

Starting the disturbance recorder ("DRE" function block, input "Start") can be programmed using the graphic equation editor (see Chapter 0). One simple example is shown in Figure 0-44.

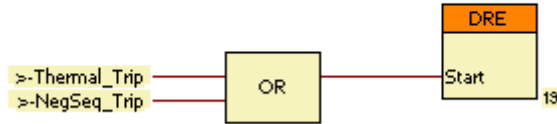

Figure 0-44 Example: Starting the disturbance recorder function

The pre-fault time, the post-fault time and the total duration (max fault time) of the disturbance record depend on parameters, which can be set in the web browser.

Control

Control channels sheet contains the controllable objects of the configuration.

Software Configuration / Control

	▲ Ix	▲ Name	▲ Title	▲ Defined by	▲ Event list	Parameters	Type	IEC101/104	IEC61850 DOI descri
	0	Common_Mod_Con_	Mode of device	Common		"N/A,On,Blocked,Test,Test/Blocked,Off",1,5,1	0043...	0	
	1	Common_LEDReset_Con_	LEDReset	Common		"Off,On",0,1,1	0043...	0	
	2	CBWear_Reset_Con_	Counter Clear	CBWear		"Off,On",0,1,1	0043...	0	
	3	DisConn_Oper_Con_1	Operation	DisConn_1		"Off,On",0,1,1	0043...	0	
	4	DisConn_Oper_Con_2	Operation	DisConn_2		"Off,On",0,1,1	0043...	0	
	5	CB1Pol_Oper_Con_	Operation	CB1Pol		"Off,On",0,1,1	0043...	0	
	6	REC79_Block_Con_	AR block	REC79HV		"Release,Block",0,1,1	0043...	0	
	7	CPUETH_DiagRst_Con_	LDCDiagnostic Reset	CPUETH		"Off,On",1,1,1	0043...	0	

Count/Limit:
8(8)/64

Figure 0-45 Control channels menu

The following modifications are allowed:

- **Title** This is a free-text field; the text will be the identifier of the Control on the LCD screen or on the web page (e.g., "Operation")

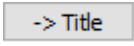
The  button copies the content of the *IEC 61850 DOI description* column to the *Title* column for all selected lines. When the current language is English then the original value, otherwise the translated value of the object's title will be modified. Please select lines carefully because the titles will be overwritten without confirmation. This feature is useful because the *IEC 61850 DOI description* field can be filled already in the Logic editor where the connections of e.g. a Con4Ch are defined. IEC 61850 Data Attributes column shows the Logical Node and DOI structure of the control.

Counters

In this menu the user can find the pre-defined Signal counters (e.g. CB switching operations) and the Cumulative Timers. Adding new counters is not allowed on master level. The following modifications are allowed on the existing counters:

- **Title** This is a free-text field; the text will be the identifier of the Counter on the LCD screen or on the web page (e.g., "Operation counter")

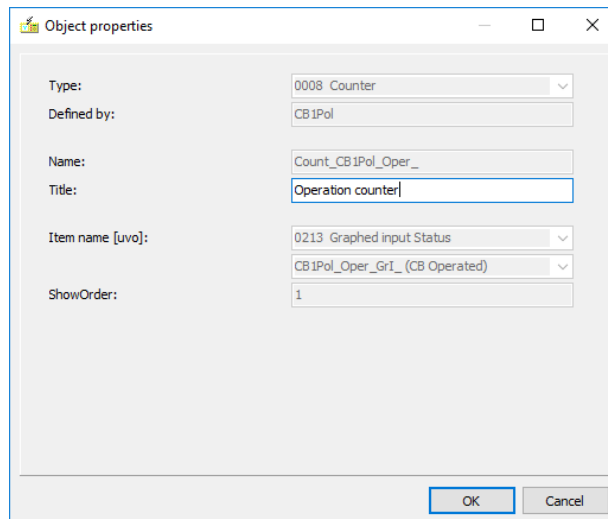

Figure 0-46 Example: Object properties window of counters

NOTE: This example shows a selection of a counter without any reference to IEC 61850. If this kind of modification of the configuration is needed, please contact Protecta support.

Matrix

The Inputs (rows) of the software matrix are binary status signals selected by the user. The columns of the matrix are the outputs. The user defines the assignments between rows and columns during the parameter setting procedure.

Matrix/ Inputs menu

When the "Matrix/Inputs" menu is opened, Figure 0-47 is displayed. In this example two rows are already defined; one with the name "MxRow1" and with the user-defined title "SynChk block". This signal is selected to be "Bin_C07". For the modification procedure, the second row is shown below where the input signal is received on the TRC94_GenTr_GrI_ (General Trip) input.

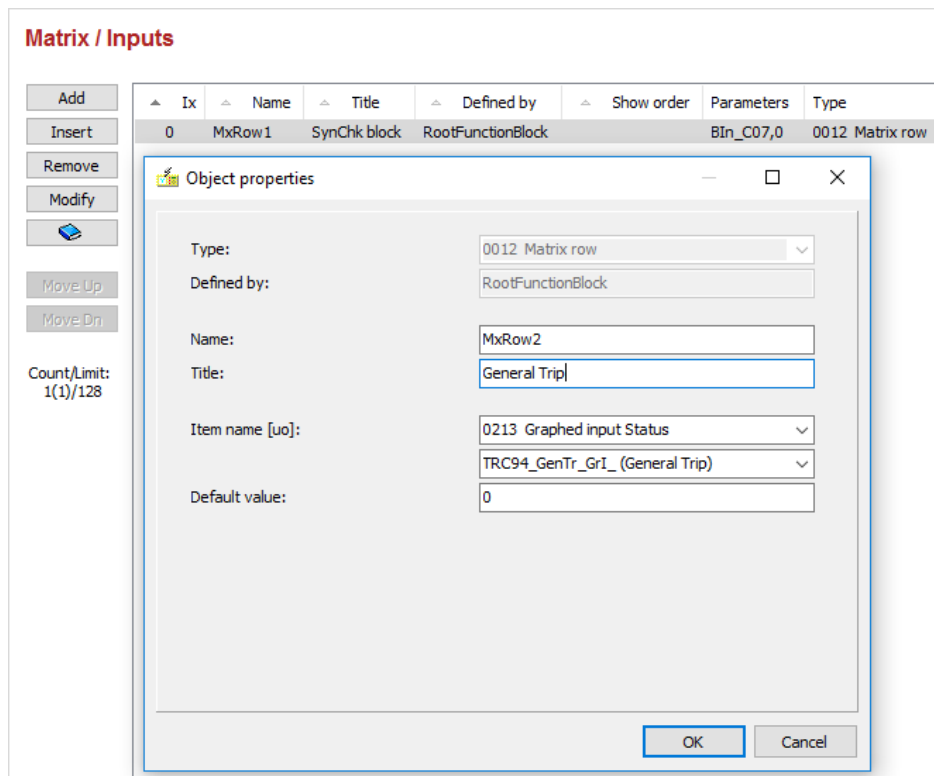

Figure 0-47 The "Matrix Inputs" window and the "Object properties" data block

The user can define

- Name the freely editable name of the row
- Title the freely editable title of the row
- Item name the type of the signal (here a "Graphed input Status") and the name of the signal (here TRC94_GenTr_GrI_ (General Trip))
- Default value the value at starting the device.

The available signal types for the matrix rows (Item name) are:

- *Filtered Binary Inputs* These are the signals from the binary inputs of the device. Filtering means that the transient changes within a limited time span are not considered as status changes.
- *Graphed input Status* These are the binary output status signals of the function blocks. These status signals are explained in details in the documents of the individual function blocks.
- *NonFiltered Binary Inputs* These are the signals from the binary inputs of the device. These signals are the non-filtered versions; they can reflect also the transient changes of the inputs.
- *Volatile user status* When editing the user logic in the Graphic logic editor (see the details in Chapter 0) the user may define new binary output status signals, and compose logic relationship resulting these signals.
- *Non volatile user status* When editing the user logic in the Graphic logic editor (see the details in Chapter 0) the user may define new binary output status signals, and compose logic relationship resulting these signals. These signals are defined to be stored in non-volatile memory. If the supply voltage of the device is switched off then it is switched on again, these signal preserve their logic status assigned during the previous energized state of the device.

Matrix / Outputs menu

The columns of the matrix are the outputs, which can be applied in the graphical equation editor (See Chapter 0) as input signals and then used according to user' requirement. The user defines the assignments between rows and columns during the parameter setting procedure.

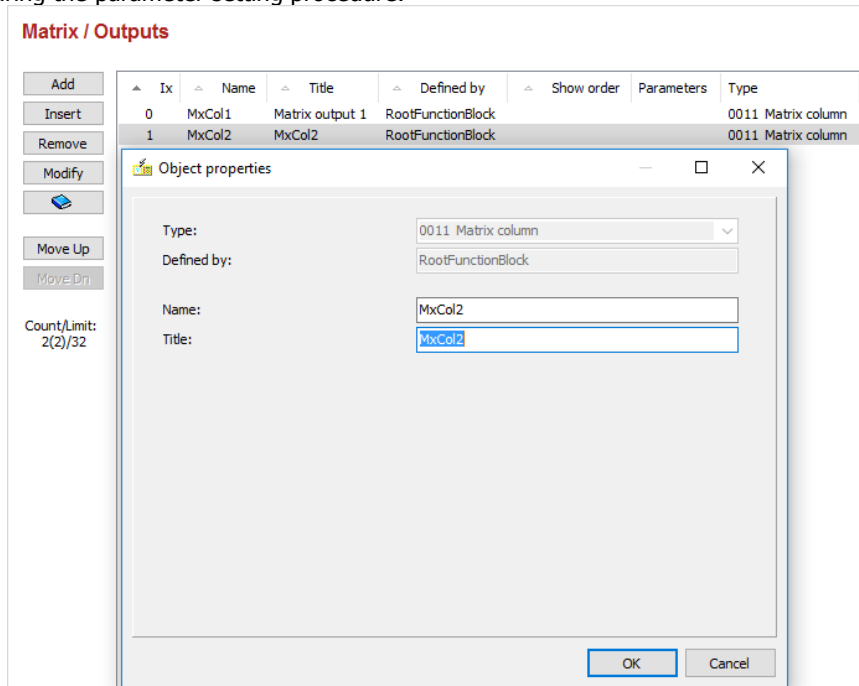

Figure 0-48 The "Matrix Columns" window and the "Object properties" data block

When the "Matrix/Outputs" menu is opened, Figure 0-48 is displayed. In this example a column is already defined with the name "MxCol1" and with the user-defined title "Matrix output 1". Now the procedure for adding a second column is displayed, where the second column name will be MxCol2 and the title is being modified.

The user can define

- Name the freely editable name of the column
- Title the freely editable title of the column. It will be shown on the web page.

THE LCD EDITOR

The "LCD editor" is embedded software used for picture generation for the LCD, integrated in the front panel of the EuroProt+ devices.

The factory configuration usually contains the basic pictures that may be needed:

- "Main", this screen displays the date and time, the names of the substations and that of the device and the IP address. With the information button "I" on the touchscreen the MAC address of the device, the version ID of RDSP/CDSP and the configuration name can also be displayed.

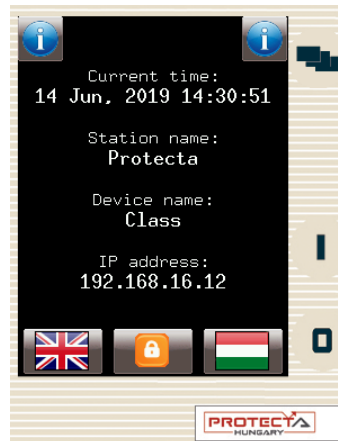

Figure 0-1 The Main screen

- "Param", this screen supports the selection of the applicable parameter sets.



Figure 0-2 The Parameter sets screen

- "On-line", this screen displays the measured values and the information collected.

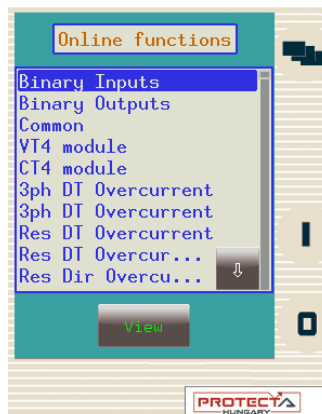
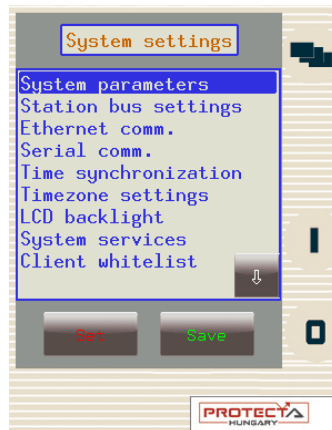

Figure 0-3 The On-line functions screen

- “Events”, the events logged in the device can be displayed on this screen.

*Figure 0-4 The Events screen*

- “System Settings”, This screen serves the purpose of displaying and editing the parameters for the hardware and communication functions.

*Figure 0-5 The System settings screen*

- Any other displays ordered by the user. E.g.:

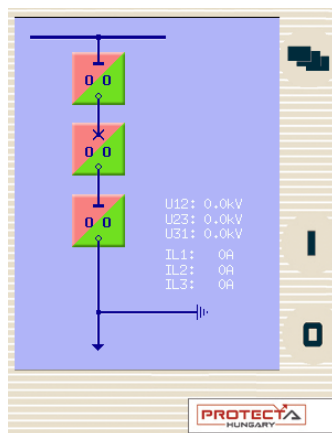

Figure 0-6 The User's screen

Using the LCD editor, the user can generate similar pictures for the LCD.

User's Manual for the LCD editor

The "LCD editor" is embedded software in the EuroCAP configuration tool for creating, editing or deleting user screens of the EuroProt+ protection devices. See Figure 0-6 as an example. These user screens can be uploaded to the device via communication connections.

The factory integrated screens:



Factory integrated screens are shown on Figure 0-1 to Figure 0-5 and with grey letters on Figure 0-8. They are not editable by the user. Displaying them can be disabled; however, their application is advised to make the local operation of the device easier.

The windows of the LCD editor:

The LCD editor works in windows. These windows can be moved with the mouse, holding down the left mouse button on the headline. Resizing is also possible if the left mouse button is held down on the edge of the window and the \leftrightarrow symbol is dragged.

Starting the LCD editor

The LCD editor is opened by clicking the  icon on the toolbar of the EuroCAP configuration tool or in the sub-menu Project/LCD Parameters.

If the  LCD button is inactive, then no EuroProt+ configuration file is open, or the access level does not allow any modification. To open a configuration file, click the  button.

Password protection:

The view modes of the software are password protected. The users can be entitled to perform various operations within the software, controlled by four pre-defined user profiles. When the EuroCAP software is started and the password for the selected view mode is entered, the required EuroProt+ configuration file can be opened and the LCD Parameters icon also becomes available.

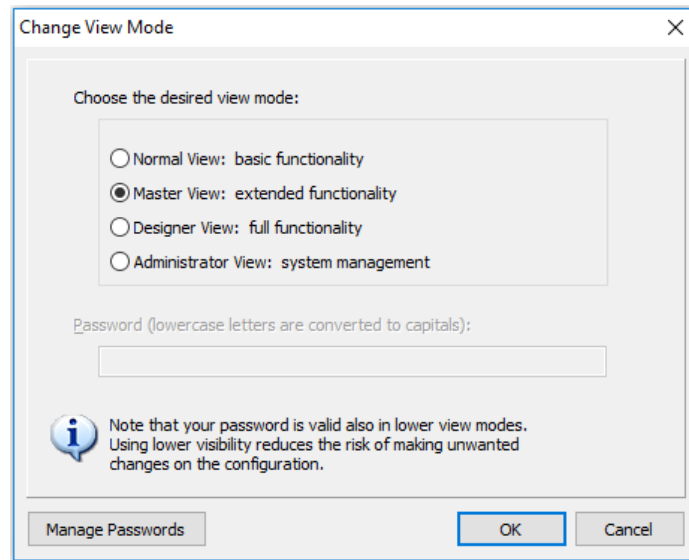



Figure 0-7 The access levels

The LCD editor is not available in „Normal View” mode.

The “LCD Parameters” window

When clicking on the  icon, a new window is opened displaying the list of available screens.

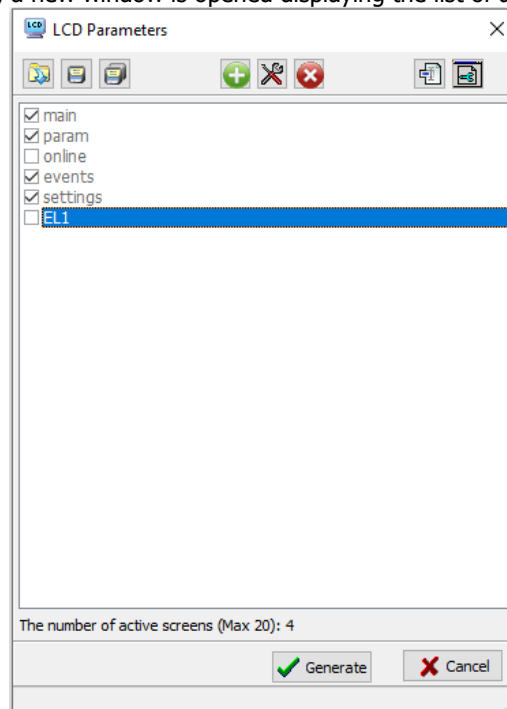

Figure 0-8 The starting screen of the LCD editor

The list contains the available screens. The checkmarks indicate the screens that can be activated on the LCD (in Figure 0-8 some of them are not active). The number of the checked screens is limited to 20. If there are checked more, the user gets error message after clicking the Generate button (see Figure 0-9).

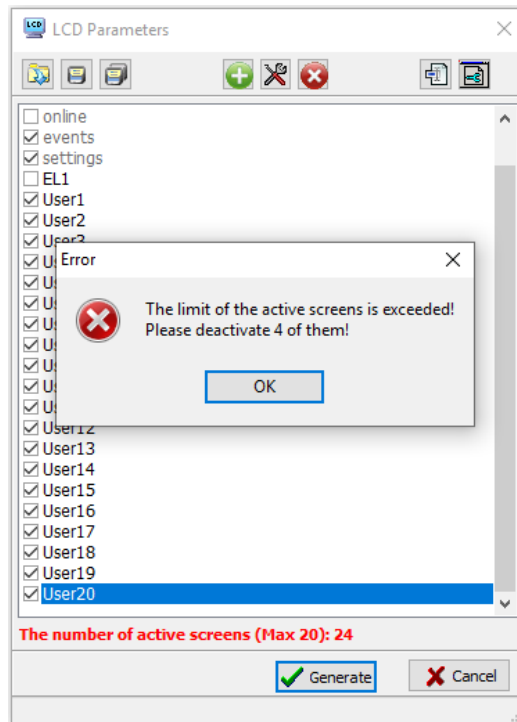











Figure 0-9 Exceeding the maximum number of active screens

The icons of the tool-bar

-  opening a user screen from a file
-  saving a user screen to a file
-  saving a user screen and Icd.conf to a file
-  generating a new user screen
-  deleting a user screen
-  editing the selected user screen
-  rename the selected user screen
-  setting the display properties (size)

The basic screens (main, param, online, events, settings) cannot be modified or deleted by the user.

The user at "Master level" can create new screens or modify the "User screens" (in Figure 0-8 e.g. "EL1" is a pre-defined user screen. It can be modified; the  icon also becomes active.)

The buttons of the toolbar are used to create  user screens or to delete  a selected user screen.

Creating new user screens

A new user screen can be created by pressing the  button. This adds a new "User" screen to the list with a new serial number.

Opening the user screen:

A user screen in the list can be opened by double-clicking on the relevant row of the list or by right-clicking with the mouse, then selecting the / Edit Screen command or by clicking the  button on the toolbar.

Relocating the user screen:

The sequence of the displayed screens can be modified by left-clicking on the row of the selected screen, and dragging the row up or down on the list to the required position.

Renaming the user screen:

Renaming can be done with the  button on the tool bar or with a right-click and the Rename command.

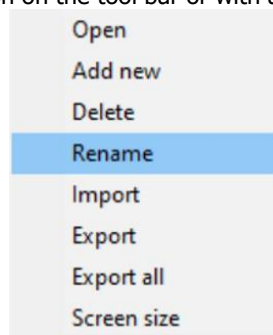



Figure 0-10 The User screen menu

Deleting a user screen:

There are three methods for deleting a user screen: the DEL button on the keyboard, right-clicking then selecting Delete or using the  button on the toolbar.

Saving the screens into a file:

For saving the screens into a file the  button of the menu bar can be clicked. Here a dialog window serves the purpose of selecting the path and name to save the information to. All selected and not factory-made User Screens will be saved in addition to the "lcd.conf" file into the selected directory. After successful saving, a message is displayed. This message can be acknowledged by clicking the "OK" button.

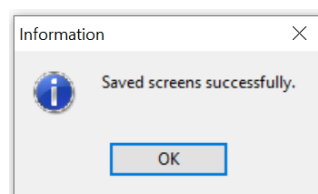



Figure 0-11 The Saved message

Saving only the screen file (*.lcd) without configuration information can be done by pressing the



button in the menu bar.

Reading the screens from a file:

To read the screens from a file, the  button of the menu bar can be clicked. Here a dialog window serves the purpose of selecting the path and name of the file to be read. Only one User Screen may be loaded. If the name of the screen already exists on the list of screens, the program asks for permission to overwrite the information.

Generating the LCD configuration:

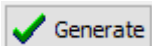
Before uploading press . The downloadable version will be generated and the editor window is closed.

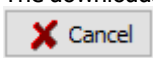
If no generation is needed, then press . The editor window is closed without generation or saving. Uploading a new screen is part of uploading a new configuration. The icons to be applied are described in Chapter 0.

Setting the LCD setup:

The window where the properties of the LCD can be set is opened using the  button. Two pre-configured resolutions can be selected (240*320, 320*240).

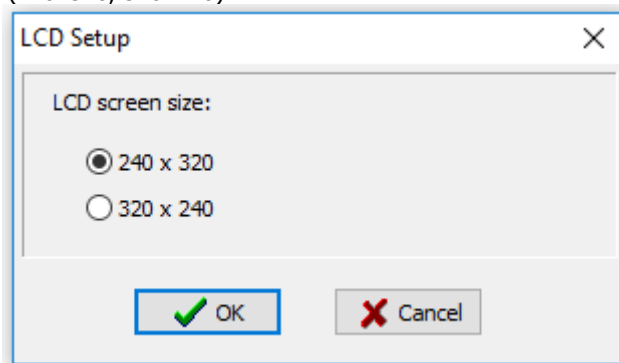

Figure 0-12 The LCD setup screen

Exit from the LCD editor:

- Save changes:

To save changes, press the  button. As a result, all changes are saved.

- Cancel changes:

If there is no need to save the modifications, press . In this case, the program asks for confirmation to reject the changes.

- Direct exit:

To quit the program, click on the close button (x) on the top right corner. If there are unsaved changes, the program asks for confirmation to reject the changes.

- Confirmation:

In the dialog window asking for confirmation, there are two choices: the  and the

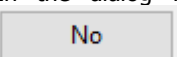
 buttons. If the  button is clicked, the changes will be lost. If the

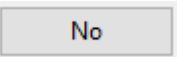
 button is clicked, the program returns to the LCD Parameters window. Similarly: when the close button (x) is clicked, confirmation is also needed.

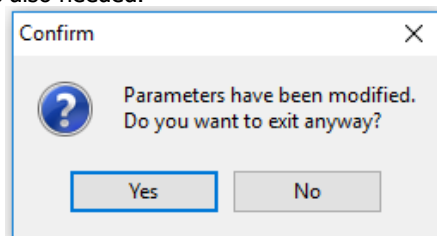

Figure 0-13 The Parameters message

Editing User Screens:

The LCD screen editor is composed of windows. The window in the middle is the graphic area showing the screen picture to be edited. The left side window is the Object List, showing the objects located on the graphic area. The window on the right side displays the properties of the selected objects. This window is also used for modification.

The toolbar is located in the upper part of the window. The icons on the toolbar are for copying and pasting existing objects. Additionally, new static and dynamic objects can be placed on the graphic area, too.

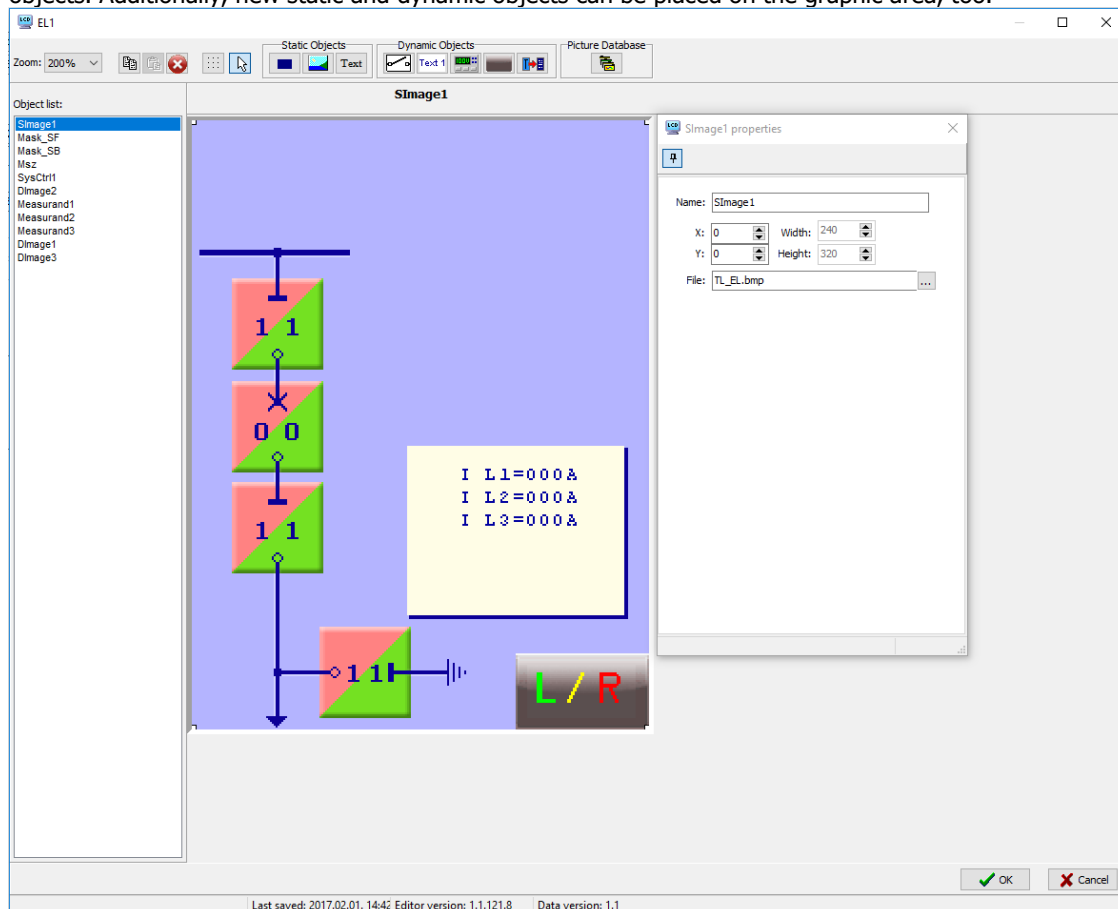

Figure 0-14 The screen editor

Zoom:

The Zoom dropdown menu supports selecting the zoom mode. The enlargement is expressed in percent.

Copying objects:

The selected object can be copied by clicking on the  button or by using the Ctrl + C key combination, or by right-clicking on the object, then selecting the Copy command. The selected object remains on the original location.

Inserting objects:

The objects placed previously on the clipboard can be inserted by clicking on the  button or by using the Ctrl + V key combination, or by right-clicking on the working area, then selecting the Paste command. The location of the inserted object will be 10 pixels down and 10 pixels to the right of the original object, but it can be dragged freely. The object remains on the clipboard, too, and it can be inserted again.

Deleting objects:

A selected object can be deleted using the  button.

Moving objects:

The selected objects can be dragged keeping the left mouse button pressed. The new location can be defined directly in the object properties window, too.

X:	21	Width:	48
Y:	79	Height:	48

Grid:

Using the grid (or raster), the objects can be placed more accurately on the User Screen. For toggling the grid, use

the  button. The distance between grid points is 4 pixels. They are invisible but if the grid is switched on, then the objects will match the grid positions.

New objects: (see below for details)

- Static objects:
 - Static rectangle (Rectangle),
 - Static picture (Image),
 - Static text (Label),
- Dynamic objects:
 - Dynamic picture (Dynamic Image),
 - Dynamic text (Dynamic Label),
 - Measured values (Analogue),
 - Switch for mode selection (SysCtrl)
 - Switch for screen selection (Screen Ctrl)

Placing a new object:

Click on the symbol (icon) of the selected object type on the toolbar, then click on the graphic area. The contour of the object will appear in the editor area. The new object can be moved as required.

The Object List:

The left side window is the Object List, showing the objects located on the graphic area. The sequence of the objects is of great importance. If an object is located at the top of the list, then the subsequent objects will overlap and cover the preceding ones. The position of the objects on the list can be modified by clicking and dragging the object while keeping the left mouse button depressed. The object names can be also overwritten by clicking on the name, then using the object properties window or by double-clicking the name.

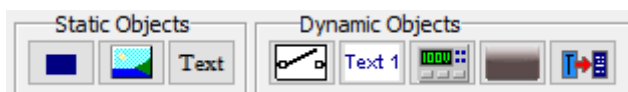
The objects:*Figure 0-15 The Objects toolbox***Static rectangle: (Rectangle)**

Using this icon, a rectangle can be placed on the screen, the size and color of which can be modified as required. The „Name” field contains the identifier, which is shown on the Object List, too. In addition to the size and the color, the position can be defined as well. When the „Fill” option is ticked, the area of the rectangle will be filled with the selected color.

Name:

X: Width:
Y: Height:

Fill

*Figure 0-16 The properties of the Rectangle***Static image: (Image)**

The first step is to place a symbolic square on the screen, the properties of which can be defined additionally. A name and the starting position can be given, then if the „Assign picture” button is pressed, the required picture can be selected from the available database.

Name:

X: Width:
Y: Height:

File:

*Figure 0-17 The properties of the Image***Static text: (Label)**

The name of the label, its size and position can be defined here. The „Text:” field contains the text to be displayed, then the „Font:” dropdown menu can be used to define the character size. The color of the text is selected using „Font Color”, the background can be colored using the „Back Color” button. To show the background color, „Fill” must be ticked.

Name: SLabel1

X: 151 Width: 35
Y: 37 Height: 13

Text: Text1

Font: small (7x13)

Font color Back color

Fill

Figure 0-18 The properties of the static text



Dynamic picture: (Dynamic Image)

The difference between dynamic and static pictures is that several states can be assigned to a dynamic picture based on external information. This external information can be selected in the „Source“ dialog box. The pictures assigned to different states can be selected from the „Files“ list. The serial number of the selected file (usually bit-map) means the value of the variable of the file is assigned too. A control command can be assigned to these dynamic images in the „Command“ dialog box. Select the required control object from the available object type „Control Channels (43)“, then assign the On and Off commands. If confirmation is required, then check the “Confirm Before Execute” box, too.

Name: CB

X: 21 Width: 48
Y: 137 Height: 48

Files:
0-Intermediate: CB_00.bmp
1-Off: CB_Off.bmp
2-On: CB_On.bmp
3-Bad: CB_11.bmp

Source
CB1Pol_stVal_ISt_ (Status)

Command
CB1Pol_Oper_Con_ (Operation)

I On
O Off

Confirm Before Execute

Figure 0-19 The properties of the Dynamic image

Text 1

Dynamic: (Dynamic text)

The treatment of dynamic text is similar to that of dynamic pictures: several states can be assigned and displayed based on external information. Text can be typed in by clicking on the "T" letter, then its size and color can be selected. The command assignment is also similar: in the „Command“ dialog box, a „Control Channel (43)“ can be assigned.

Name: Status

X: 152 Width: 98
Y: 47 Height: 13

Texts: 0-False: SynChk OK
1-True: SynChk Blocked

Font: small (7x13)

Font color Back color

Fill

Source: BIn_G07 (SynChk block)

Command: [] [X]

I Not Used
O Not Used

Confirm Before Execute

Figure 0-20 The properties of the Dynamic text

Measured value: (Measurand)

To display measured values, the following information must be assigned: name, location and size. „Prefix“ means the short text to be displayed as static text before the displayed value, „Suffix“ means the short text added to the displayed value. The number of the displayed digits can also be defined under „Spacing“. The source of the measured value is selected using the „Source“ dropdown list.

Name:

X: Width:
Y: Height:

Prefix:

Suffix:

Spacing:

Font:

Fill

Source

Figure 0-21 The properties of displaying a measured value

Toggle mode of operation: (SysCtrl)



This button on the user screen is used to set the local/remote operational mode for one channel in the common function block. There are four channels available in the common FB and after selecting the desired one the user has to set the operating mode.

The list of available operating modes (values):

- Disable all
This option disables all operations.
- Local only
This option enables local operation only.
- Remote only
This option enables remote operation only.
- Both enable
This option enables both local and remote operation.
- Invert Remote
This option is for toggling remote operation.
- → Local → Remote →
This option is for switching between operating modes.
- → None → Remote →Local → Both →
This option sets disabled, remote, local and full enabled operating modes in turn.

The above values describe the selected control channel output value in the common FB after touching the SysCtrl button. Additionally, it is also possible to set confirmation for command generation.

Apart from the "usual" information (name, position, file of the image), some additional information can also be defined: there are three options available for "Button Width": 40, 70 or 85 pixels. The button width determines the required size of the image as well: for a width of 40 pixels, it is 40*40, for 70 it is 40*70, and for 85 it is 40*85. No other sizes can be applied.

Name: SysCtrl1

X: 170 Width: 70
Y: 280 Height: 40

File: LR.bmp ...

Button Width: 70

Confirm: SysCtrl1

Channel: Local/Remote Switch 1

Value: -> Local -> Remote ->

Figure 0-22 The properties of a dialog for confirmation

Screen control: (ScreenCtrl)

Caution! This function is supported from CDSP firmware version 1530 and higher only. Loading the configuration to a device with an older CDSP version will result in LCD malfunction!

This button on the user screen is used to jump to another user screen.

There are two options for the symbol to be used on the screen:

- Select a picture from a file
- Use text (by selecting this option a standard symbol will be shown in the background of the text)

Apart from the "usual" information (name, position, file of the image), some additional information can also be defined: there are three options available for "Button Width": 40, 70 or 85 pixels. The button width determines the required size of the image as well: for a width of 40 pixels, it is 40*40, for 70 it is 40*70, and for 85 it is 40*85. No other sizes can be applied, and if the size is wrong, the database cannot be closed. The button with setting will be applied for image selected from a file but also for text option.

Name: ScreenCtrl1

X: 137 Width: 40
Y: 44 Height: 40

File: ...

Button Width: 40

Text: EL 1

Font: small (7x13)

Font color

JumpTo: EL 1

Figure 0-23 The properties of a dialog for confirmation

Status bar:

The Status bar contains three important bits of information: date and time of the last saving, the version identifier of the software and the version identifier of the database.

Last saved: 2/1/2017 2:42:06 Editor version: 1.1.121.8 Data version: 1.1

The object properties window:

This is a separate window located on the right side of the computer's screen, displaying the properties of the selected object. If this window is not needed, it can be closed using the "X" button. To re-open this window, simply double-click on the object needed.

Right-clicking on an object:

When right-clicking on an object, the following menu is displayed:

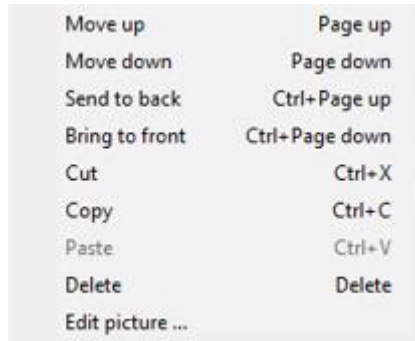

Figure 0-24 The menu of an object

- Move up:

This menu item moves the selected object one position up on the object list. This means that all objects located lower on the object list will be on top of the selected object.

- Move down:

This menu item moves the selected object one position down on the object list. This means that the selected object will be on top of all objects located higher on the object list.

- Send to back:

The selected object will be sent to the background and covered by all other objects.

- Bring to front:

The selected object will be sent to the foreground covering all other objects on the list.

- Cut:

This menu item cuts the selected object and places it on the clipboard.

- Copy:

This menu item copies the selected object to the clipboard.

- Paste:

This menu item inserts the object previously placed on the clipboard to a new location, which is 10 pixels down and 10 pixels to the right from its original position. This inserted new object can be moved freely to any other position.

- Delete:

This menu item deletes the selected object.

- Edit picture:

This menu item serves to edit the active picture element. Editing will be performed by the Windows-default graphic editor. All required changes can be made here.

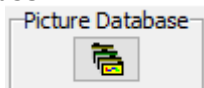
The LCD Picture Database:

The LCD Picture Database contains all pictures applicable on User Screens. The unused pictures may be deleted, new pictures can be added for future application. The content of the database is displayed if a static or dynamic picture or a SysCtrl switch needs picture assignment.

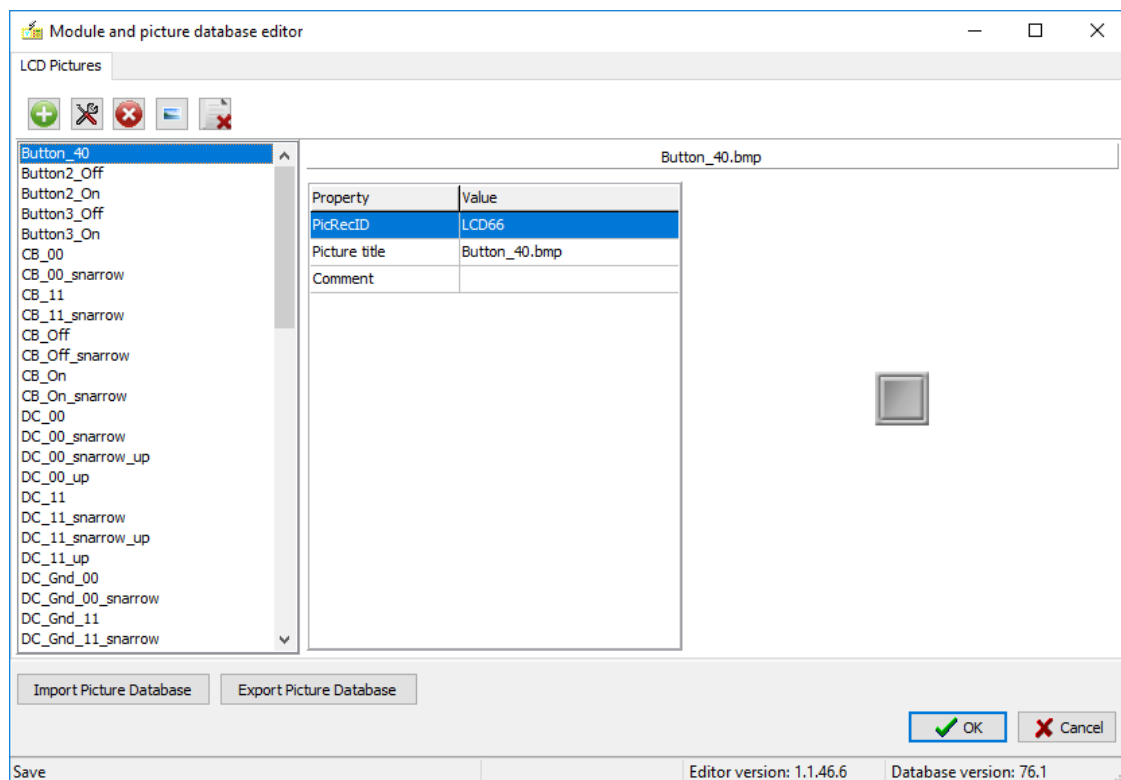



Figure 0-25 The database editor

Importing a new picture to the database:

The  button is for importing a picture to the database. After pressing this button, a file selection dialog serves the purpose of locating the required picture.

Replacing a picture in the database:

A picture can be changed by pressing the  button and replacing it with another one.

Editing a picture:

To edit a picture, simply right-click on the selected picture and activate the „Edit Image” menu item or press the



icon. The windows-default picture editor will be opened to perform the required modifications.

Deleting a picture from the database:

A picture can be deleted from the database by selecting the picture and pressing the  button. For deleting all

LCD pictures from the list press . Only pictures not applied on the user screen may be deleted.

Inserting a selected picture:

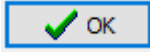
A selected picture can be inserted by pressing the  button.

Discarding changes:

If there is no need to save the performed changes, simply press the  button. The LCD Picture Database will be closed and the changes will be lost.

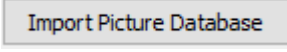
Importing and export the picture database is also possible with the  and

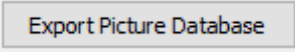
 buttons. When importing a new database, the existing database will be overwritten.

Composing a new user screen

The procedure of composing a new screen is best explained through an example.

Let's compose a screen for the following task:

EXAMPLE: A feeder bay for a 20 kV substation will be composed. The applied scheme is shown in Figure 0-26.

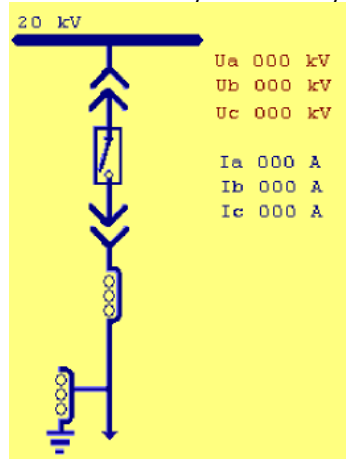

Figure 0-26 Required user screen for a feeder bay

The scheme includes:

- A voltage transformer; the measured phase voltages will be displayed
- A current transformer; the measured phase currents will be displayed
- An active circuit breaker
 - The status is received on two bits (ON, OFF)
 - Position indication: ON, OFF, INTERMEDIATE, BAD
 - Active element to support switching on/off from the screen with command confirmation
- A pair of active disconnectors
 - The status is received on two bits (ON, OFF)
 - Position indication: ON, OFF, INTERMEDIATE, BAD

1

The proposed steps are as follows:

The required hardware environment

There must be at least one voltage transformer input module and one current transformer input module configured in the device. (See HW configuration.)

There must be at least one relay (trip) binary output module in the device. (See HW configuration.)

There must be at least one binary input module in the device. (See HW configuration.)

2 The required software environment

The software configuration of the device must include

- a module for generation of measured voltage and current values
- a module to process the information related to the circuit breaker
- a module to process the information related to the disconnecter

The inputs of the software module MXU_L are the calculated Fourier components and true RMS values of the voltages and currents, and these values are offered for displaying, logging, etc. This example is going to display the true RMS values of phase voltages and phase currents. These are:

MXU_U1_OLM_ (Voltage L1)

MXU_U2_OLM_ (Voltage L2)

MXU_U3_OLM_ (Voltage L3)

MXU_I1_OLM_ (Current L1)

MXU_I2_OLM_ (Current L2)

MXU_I3_OLM_ (Current L3)

The CB1Pol circuit breaker module inputs the status signals received from the circuit breaker, and calculates the values of the enumerated variable:

CB1Pol_stVal_ISt_ Intermediate, Off, On, Bad

The outputs of the CB1Pol circuit breaker module are the switching commands to the circuit breaker:

CB1Pol_Oper_Con_ Command

The DisConn_LineDC disconnecter module input inputs the status signals received from the disconnecter and calculates the values of the enumerated variable:

DisConn_stVal_ISt_ Intermediate, Off, On, Bad

3 Preparation of graphic elements

There is a default set of available pictures to create representations of CB, DC elements, indicators, buttons, switches, etc. Other elements, such as busbar drawings (see below) must be created by the user with an external graphic editor program (e.g. Paint). These elements will be stored in a directory using the indicated file names. The following elements are needed:

The passive background containing the scheme (240 x 320 for small-LCD devices or 320x240 for large LCD devices).

The freely selected file name is *Feeder1B_simple_meas.bmp*.

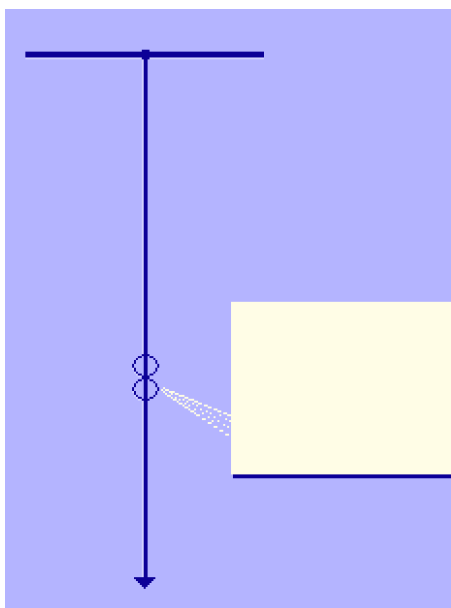

Feeder1B_simple_meas.bmp*Figure 0-27 The background (Example)*

The active scheme of the circuit breaker can display the closed position, the open position and symbols for intermediate and bad status.

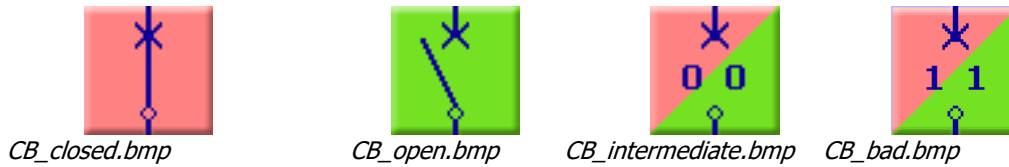
*Figure 0-28 The pictures of a circuit breaker (Example)*

The active scheme of the disconnector can display the upper and lower component in the closed position, in the open position and symbols for intermediate and bad status for both positions.

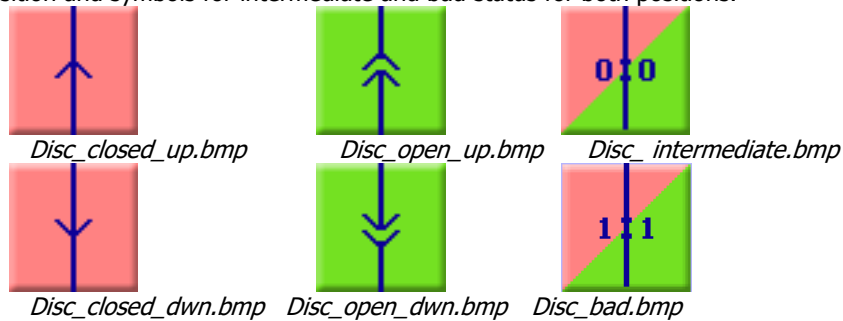
*Figure 0-29 The pictures of a disconnector (Example)*

4 Working in the graphic LCD editor

Open the graphic LCD editor clicking on the  icon. You will see the window shown in Figure 0-8, then start with "Create User Screen". A new item will appear on the list: "User1". Navigate the cursor to this item; then you have three options for opening the editor window:

- double-clicking on "User1" (only user screens are available for editing)
- clicking the  icon (when the cursor is on "User1")
- right-clicking on "User1" and then selecting "Edit Screen".

You will get an empty editor window (or the window displays the previously edited screen(Figure 0-30 The empty LCD editor window (Example)

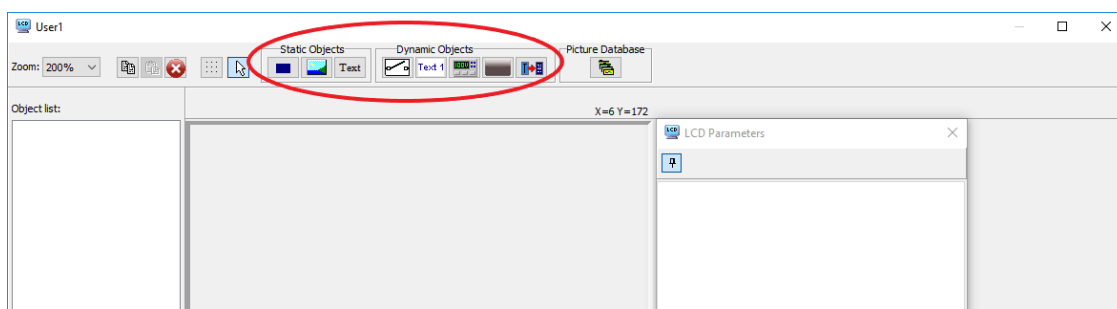

Figure 0-30 The empty LCD editor window (Example)

In this procedure, the "Static Object" icons and the "Dynamic Objects" icons will be used.

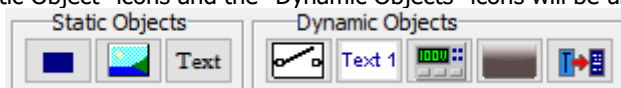



Figure 0-31 The Objects toolbox

First create the passive background. Click on the static  icon, and then click on the area in the middle of the screen (the editor window). In the editor window, a square symbol is drawn with black lines, the LCD Parameters window is filled with the dialog boxes. The *Feeder1B_simple_meas.bmp* file should be selected but, unfortunately, it is missing from the "Picture Database". When clicking on the

File: 

file selection, the screen in Figure 0-32 is displayed.

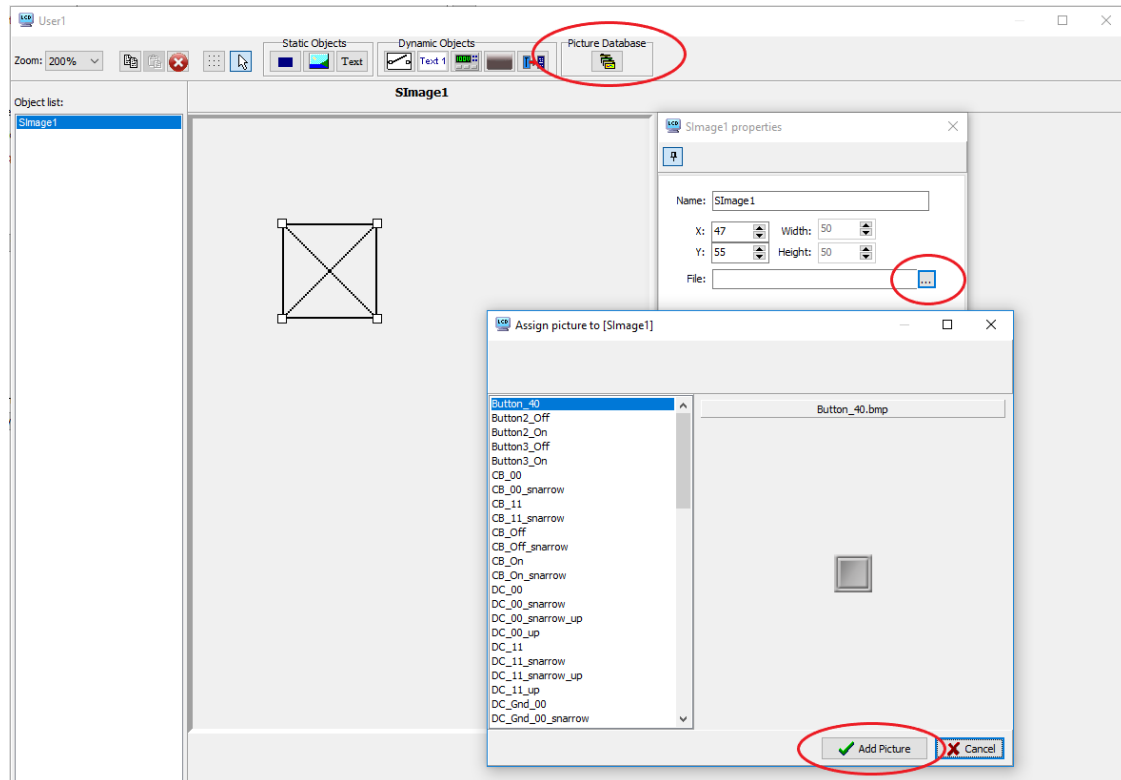
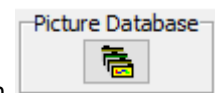

Figure 0-32 The LCD editor window for picture selection



To **import the previously prepared .bmp files**, click the "Picture Database" button and select the button for adding (Green +, see Figure 0-33). In the "Set picture properties" window click on "Load Picture" (see Figure 0-33).

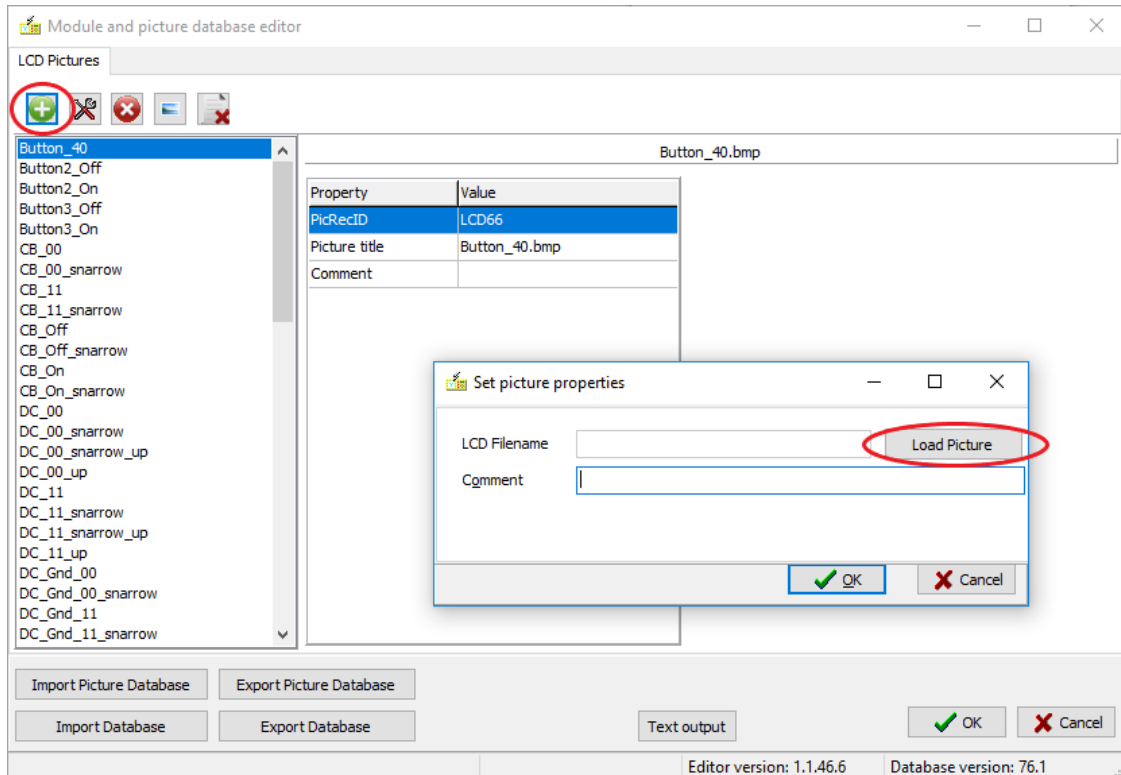

Figure 0-33 Adding new pictures to the picture database

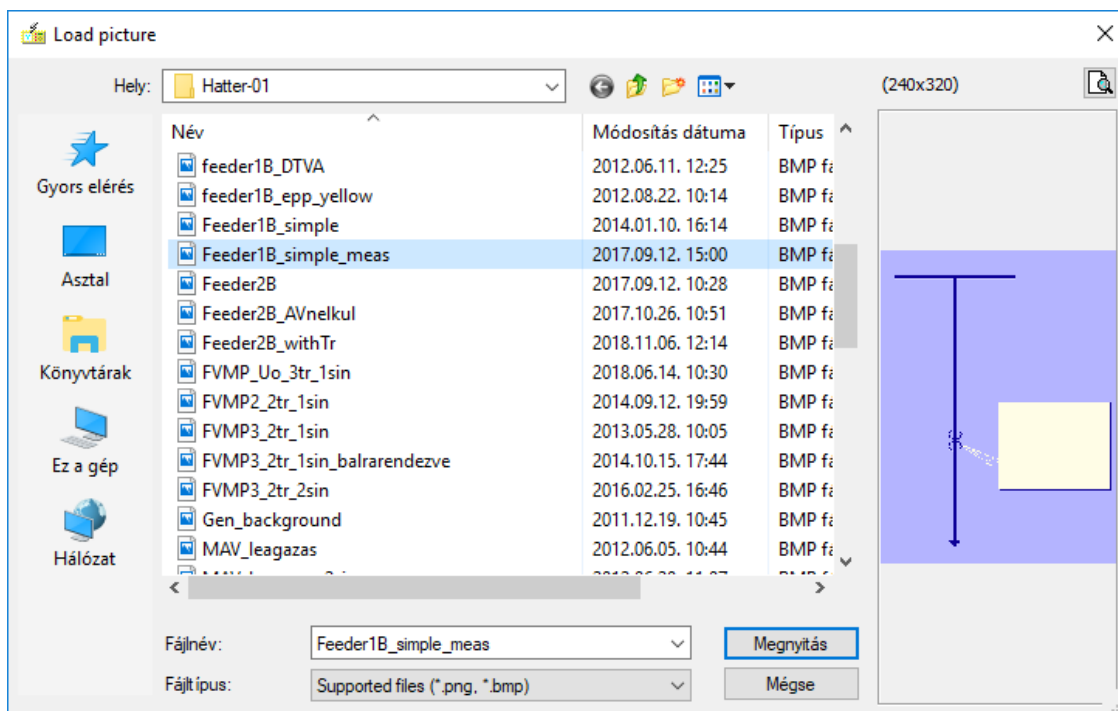

Figure 0-34 Selecting a prepared .bmp picture

Placing the background on the graphic editor window

Now that the database is complete, the background can be placed on the graphic editor window as shown in Figure 0-35. Select *Feeder1B_simple_meas.bmp* and click "Add picture". Using the "Drag and drop" technique (or typing the X and Y coordinates), find the optimal location for the background.

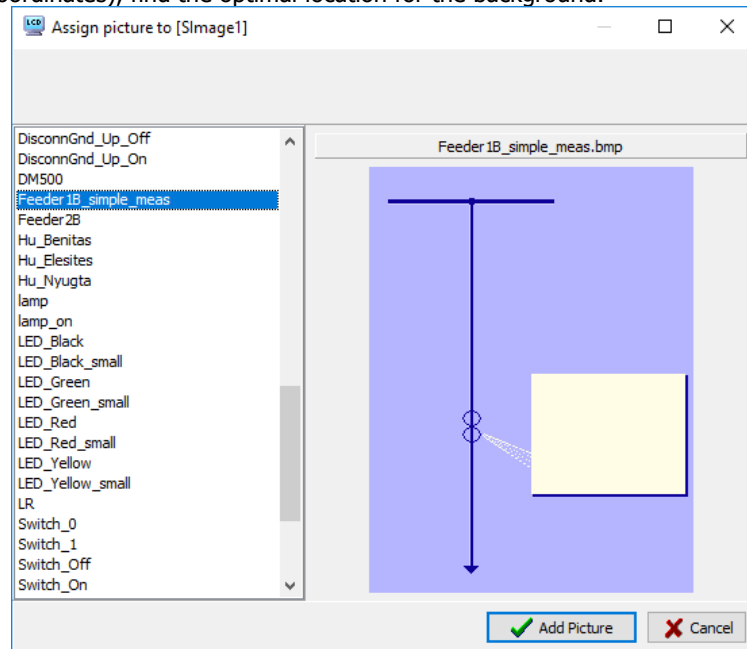

Figure 0-35 Selecting the background

Placing the CB dynamic object

As shown in Figure 0-36, select the "Dynamic object" icon, then click on the desired location of the CB symbol in the graphic editor window. In the "DImage1 properties" window, select "Source". In the opened "Choose object" window, first select "Integer status", then the CB1Pol_stVal_IST_ integer status variable. This will deliver the status of the CB, to be displayed with the prepared CB images.

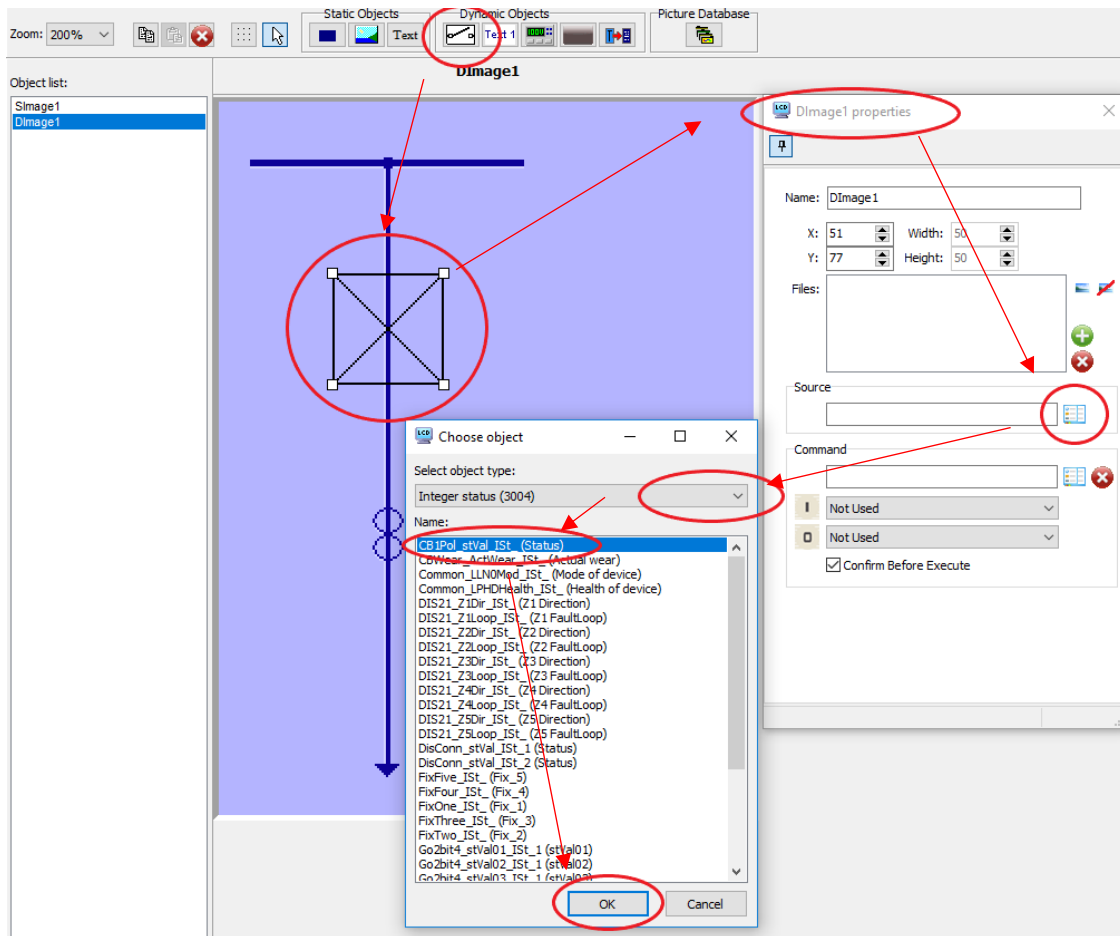

Figure 0-36 Selecting the source of the CB status indication

Selecting the CB symbols

Once the source of the CB status is selected, the "DImage1 properties" window requires 4 files (0-Intermediate, 1-Off, 2-On, 3-Bad). When on any of these rows is double-clicked, the "Assign Picture to" window is opened. Select the required .bmp file. Figure 0-37 shows the stage where "Intermediate" and "Off" have already been selected; now the picture for the "On" state is being selected. Finish all four files one by one using the "Assign Picture to" button.

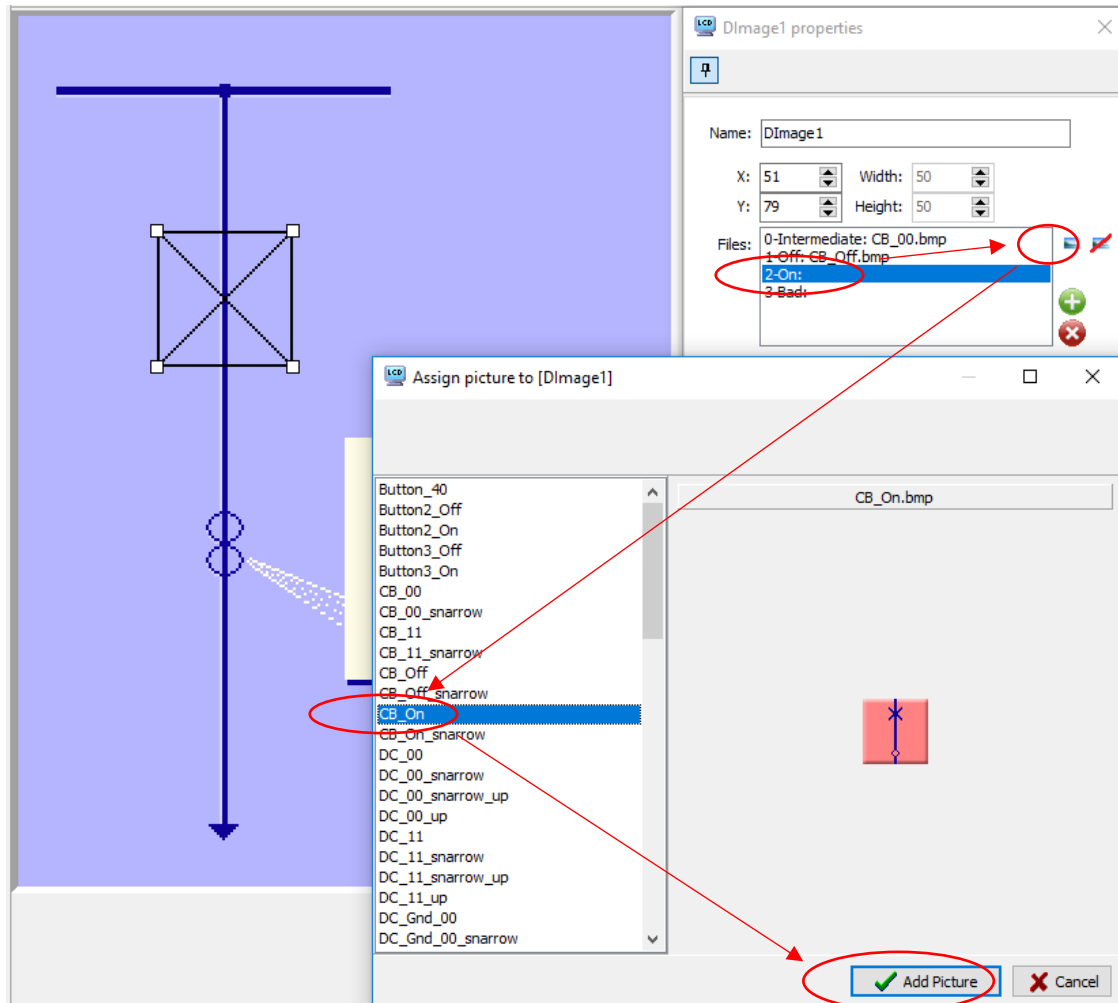

Figure 0-37 Selecting the pictures for the CB status indication

Selection ON and OFF commands

In the "DImage1 properties" window, select "Command", then in the "Choose Object" window, first select "Control channels" and the "CB1Pol_Oper_Con_" control variable. See Figure 0-38.

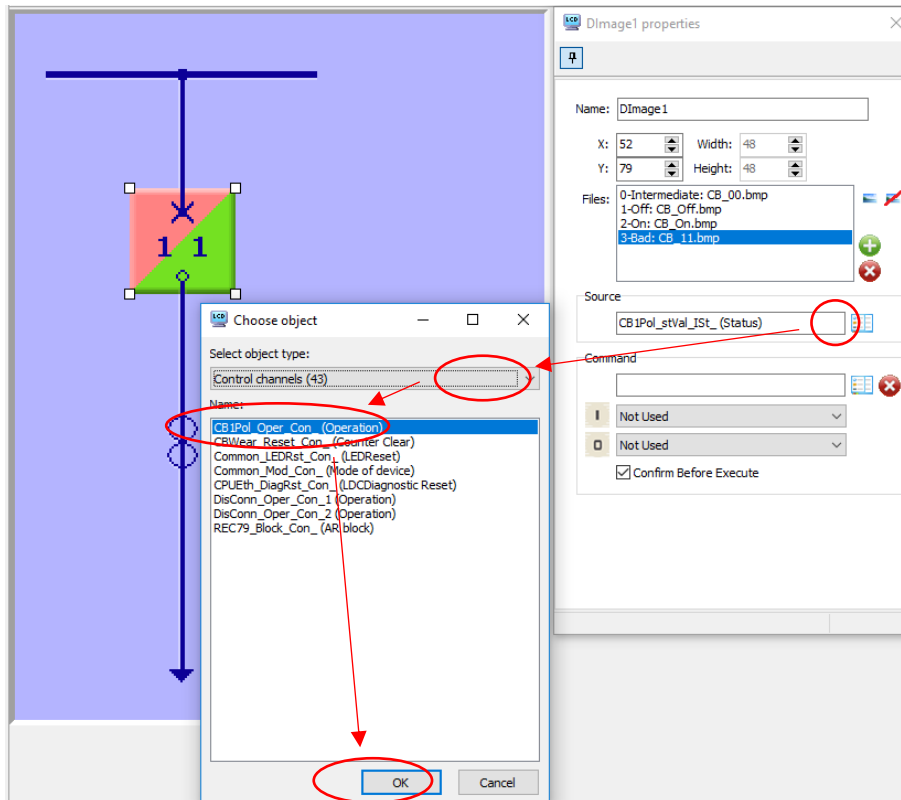

Figure 0-38 Selecting command variable for the CB switching

The on and off commands must be assigned to the buttons "0" and "1" on the front panel. This is done according to Figure 0-39.

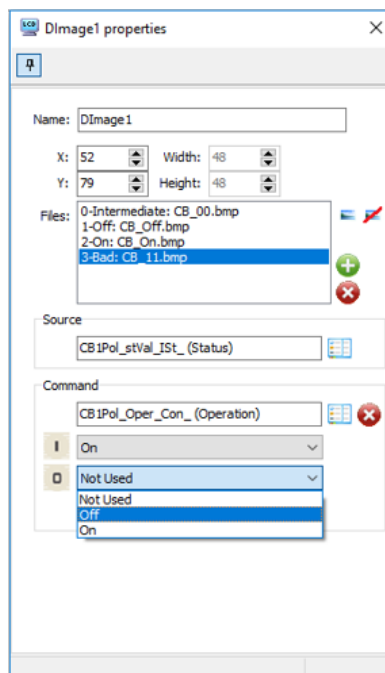



Figure 0-39 Assigning the "0" and "1" buttons to CB switching

Here the "On" command has been assigned to button "1" and the "Off" command is being assigned to button "0" using the dropdown menu.

Procedure for the "Disconnecter" dynamic object

This procedure is similar to the one used for the CB but no remote command is possible; the operation is performed manually. Please repeat the referred procedure without command assignment.

Inserting measurements on the screen

Figure 0-40 shows the procedure. First select the measurement  dynamic object. Click on the required location on the editor screen. The "Analogue properties" window requires the static text (Prefix), Font color, Back color. Select them as needed. Clicking on the "Source" line opens the "Choose object" window. Select "Online measurands" from the dropdown menu, then select the source (here MXU_IL3_OLM). This figure shows that IL1 and IL2 have already been selected. Now IL3 is being selected, which automatically determines the Suffix in Amps as well. Voltage measurement can be inserted similarly.

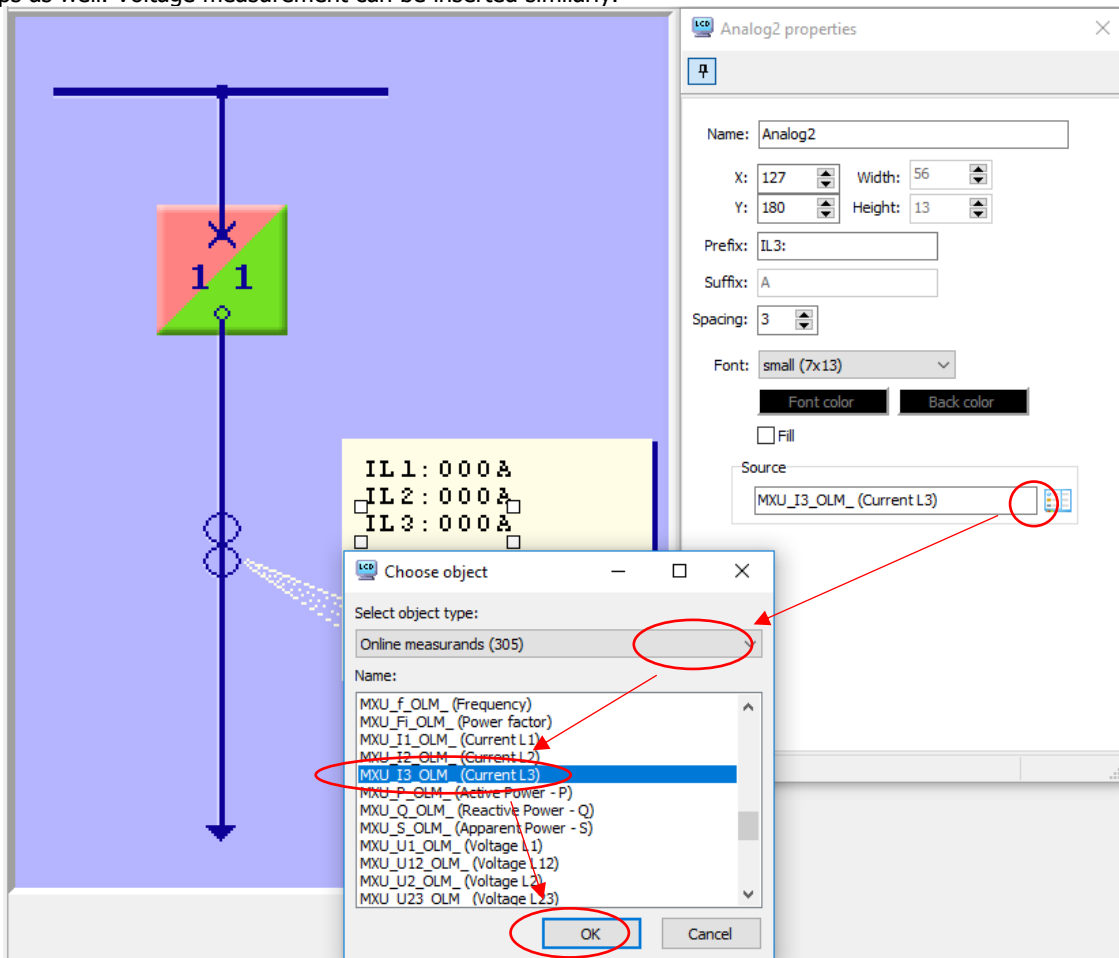

Figure 0-40 Inserting measurements on the screen

Finally, save the new screen and generate the LCD for the configuration.

(Based on this guide, the application of other elements should not cause any problem.)

For the detailed description of the LCD screen editor, see the Chapter 0 "User's manual for the LCD editor" above.

THE OFFLINE PARAMETER SET EDITOR

The EuroCAP configuration software provides a special tool for processing the parameter sets of the EuroProt+ devices. The following operations are possible:

- Reading the parameter values from a .par file *
- Modifying the parameter values off-line
- Saving the parameters to a .par file *
- Exporting and importing the parameter files to and from Excel files
- Preparing "RIO" files for testing some of the protection functions implemented in the EuroProt+ configurations

- Printing the parameter settings

The EuroCAP configuration tool cannot perform the following operations:

- Uploading directly the operating parameters from a EuroProt+ device
 - Uploading directly the operating parameters to a EuroProt+ device
- These tasks are supported by the webpage of the devices accessible via the recommended internet browsers. In general, there are two scenarios, when the user has to work on parameter settings off-line and then load them into the device. The recommended procedures are the following:
- Creating parameter settings for a new application (open the off-line parameter set editor, the standard parameter set will be loaded, type in the desired parameter values, save them as a .par file*, the created .par file* can be loaded into the device with the web browser)
 - Modifying parameters of an existing device (save parameters from the device with the web browser as a .par file*, open the off-line parameter set editor, the standard parameter set will be loaded, load the .par file* saved from the device, modify parameters as required and save the changes, the modified .par file* can be loaded into the device with the web browser)

After creating or modifying parameters in the off-line editor it is also possible to save the changes. As previously mentioned, by opening the Off-line Parameter Set Editor always the standard parameter set will be loaded. With the button "Set as Default Parameters" any change on the parameters can be saved as a new default for the actual configuration.

Starting the off-line parameter set editor

The off-line parameter set editor is started by clicking the  icon on the toolbar of the EuroCAP configuration tool. The alternative method of opening is to select Project / Off-line parameter set editor from the menu. When the off-line parameter set editor is started, the long window shown in Figure 0-1 is displayed. This window can be scrolled and contains all parameters of all implemented functions. The parameters are grouped in boxes (e.g. "Common", in this case, the Ext LR source, the CT4 module, etc., see Figure 0-1.) The parameters at startup are the factory default parameters.

Offline Parameter Set Editor [EPC Default]

User defined objects

2000	↑↓	msec	(200 - 20000 / 10)
2000	↑↓	msec	(200 - 20000 / 10)

Common

Ext LR Source

VT4 module

Range	Type 100	↓	
Connection U4	Ph-Ph	↓	
Direction U1-3	Normal	↓	
Direction U4	Normal	↓	
VT correction	100	↑↓	% (100 - 115 / 1)
Rated Primary U1-3	100.00	↑↓	kV (1.00 - 1000.00 / 0.01)
Rated Primary U4	100.00	↑↓	kV (1.00 - 1000.00 / 0.01)

CT4 module

Rated Secondary I1-3	1A	↓	
Rated Secondary I4	1A	↓	
Starpoint I1-3	Line	↓	
Direction I4	Normal	↓	
Rated Primary I1-3	1000	↑↓	A (100 - 4000 / 1)
Rated Primary I4	1000	↑↓	A (100 - 4000 / 1)

DeadLine Detection

Operation	Off	↓	
Min Operate Voltage	60	↑↓	% (10 - 100 / 1)

Figure 0-1 The Offline Parameter Set Editor window

The available icons are:

- for reading the parameter values from a file (.par file).
- for saving the parameter values to a file (.par file)
- for exporting the parameter file to an Excel file
- for importing the parameter file to an Excel file
- for printing the parameter values
- for generating input parameters for a relay test set
- for translation; when pressing this button, a new window shows the available languages:

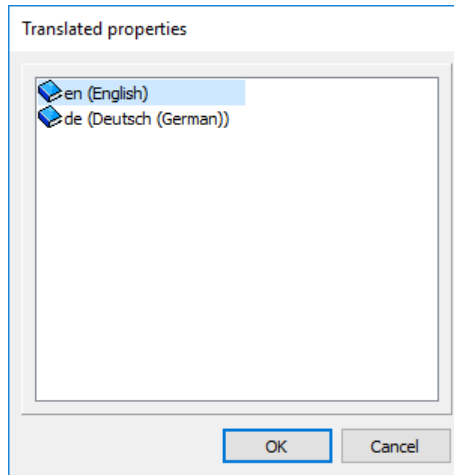

Figure 0-2 The window for language selection (Example)

NOTE: the default language of the Offline Parameter Set Editor is the selected language of EuroCAP, see Paragraph 0.

- **Set as Default Parameters** set actual parameter set as a new default. By re-opening the parameter set editor, the saved parameters will be loaded as default.

Editing the parameter values

After reading the parameters from a file (or having the default values), the parameter settings can be modified and the modified values can be saved to .par file.

Setting options

Figure 0-3 shows the usual setting methods:

- Checkbox
- Dropdown menu
- Numerical value

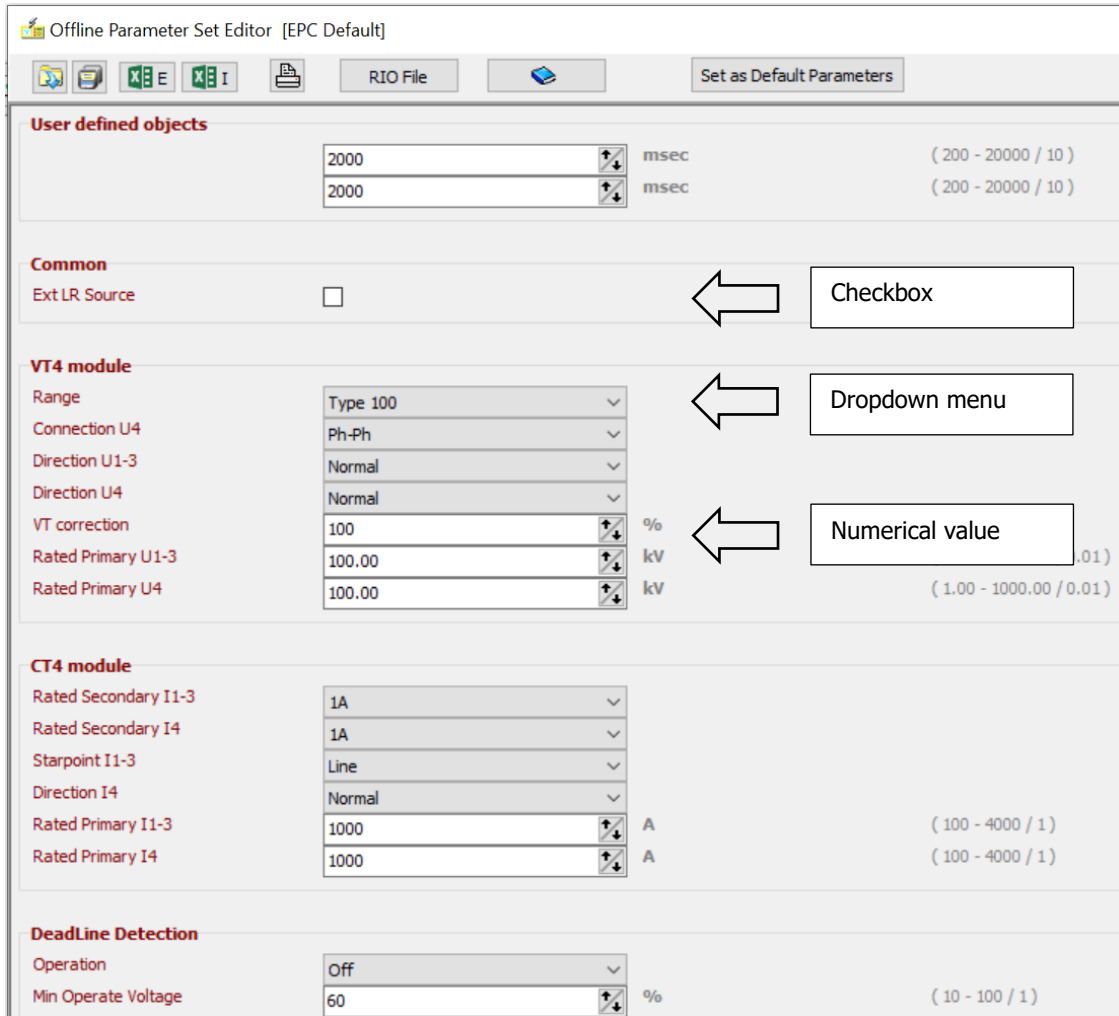

Figure 0-3 Setting methods in the Offline Parameter Set Editor

Figure 0-4 shows an example of selecting an alternative from a drop-down menu (in this case, Voltage Transformer Supervision). The title of the changed parameter value is indicated by blue colour to warn the user of unsaved modification (The changes against the *default settings* are indicated).

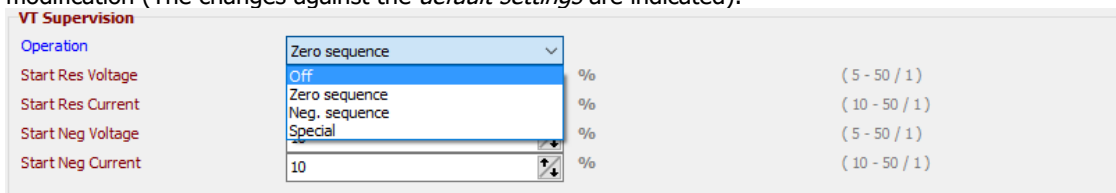

Figure 0-4 Example: dropdown menu

Helptexts

Helptexts are descriptions for parameters intended to assist the user to clearly understand what a given parameter is about. Where a parameter has a helptext, a question mark is displayed beside the parameter name. See Figure 0-5 below. To display the helptext, hover over the question mark with the mouse cursor.

3ph Time Overcurrent 1

Operation	Off		
Start Signal Only (?)	<input type="checkbox"/>		
Start Current	200	%	(10 - 3000 / 1)
Time Multiplier (?)	1.00		(0.05 - 999.00 / 0.01)
Min Time Delay (?)	100	msec	(40 - 60000 / 1)
Definite Time Delay	100	msec	(40 - 60000 / 1)
Reset Time (?)	100	msec	(60 - 60000 / 1)

Figure 0-5 Parameters of a function showing helptexts in question marks "(?)"

Exporting and importing the parameter files to and from Excel files

It is possible in the Offline Parameter Set Editor to export the parameter file to an Excel file, edit it in the MS Excel software and import the spreadsheet back to the editor. The only criterion for the use of these functions is an installed Microsoft Excel software on the computer. No other type of spreadsheet software is acceptable.

To start the export procedure, simply press the  button. The file name and location must be selected in the usual file selection dialog window, then the file is saved.

If the user starts an import procedure by the  button, he has to choose from the existing sheets in the Excel file:

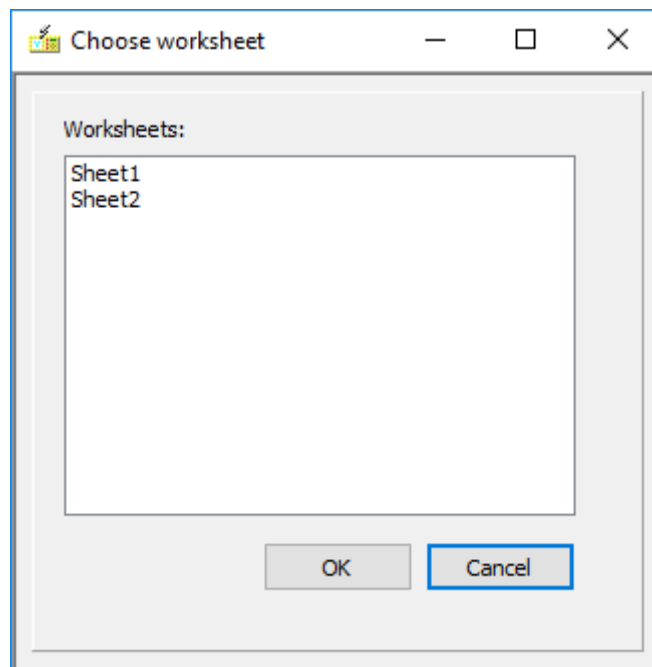

Figure 0-6 Selecting worksheet from an MS Excel file

If the Excel file is correct, its settings will be copied into the Offline Parameter Set Editor.

If however there are one or more settings which are out of the setting range, the import process will not be executed. The displayed error message will be like this:

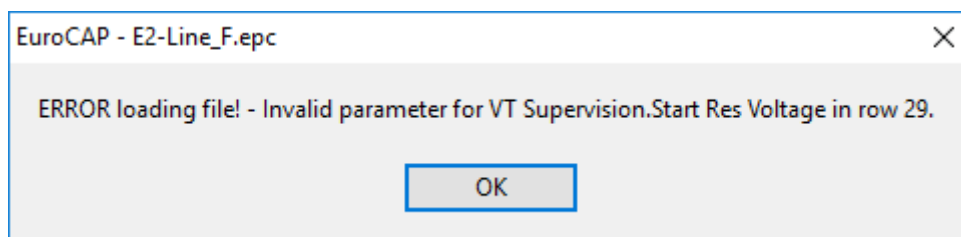

Figure 0-7 Error message because of one or more settings are out of range

If the Excel file was exported from a different type of configuration (which has different functionblocks), the import procedure will be also stopped with this error message:

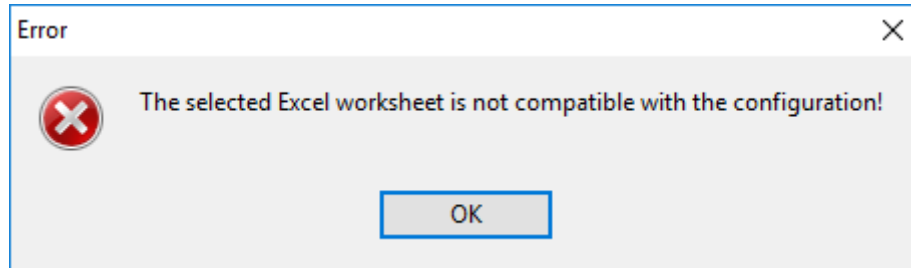

Figure 0-8 Error message because of missing function blocks in the Excel file

If the Excel file includes extra function blocks over that are in the configuration, the import process will be executed. The settings of the extra function blocks will be ignored.

Application of RIO files for testing

When a function is to be tested, the parameters of the function and the parameters of the testing device must be set to the same parameter values. The purpose of testing is the verification of correct operation.

To make the test procedure error-free and easy, RIO files are applied. At present, the Offline Parameter Set Editor supports the generation of RIO files only for 3 different types of the "5 zone Distance" protection function (normal, with independent characteristics for ph-n and ph-ph faults and with independent arc resistance parameter for ph-n and ph-ph faults). Furthermore, two types of parametrization of the test set regarding the network modelling is available (positive sequence impedance or loop impedance calculation). To start the procedure of RIO file

generation, simply press the **RIO File** button.

Figure 0-9 shows the RIO file generation window. Here the RIO Template for the distance protection function is selected

- phs: positive sequence impedance calculation,
- loop: loop impedance calculation,
- phsEnh: positive sequence impedance calculation with independent characteristics for ph-n and ph-ph faults,
- phsR: positive sequence impedance calculation with independent arc resistance parameter for ph-n and ph-ph faults

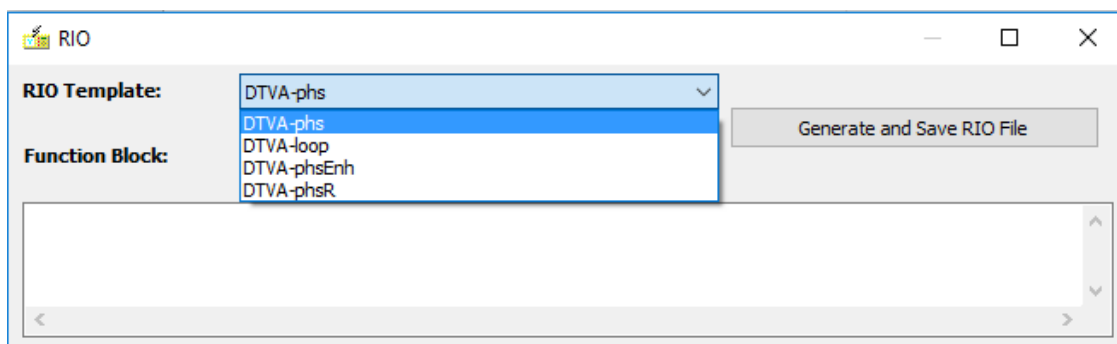

Figure 0-9 Example: RIO Template selection

Figure 0-10 shows, on an example, how the "5 zone Distance" protection function is selected for testing. (At present there are no RIO templates for other functions, only for the different types of distance protection function.)

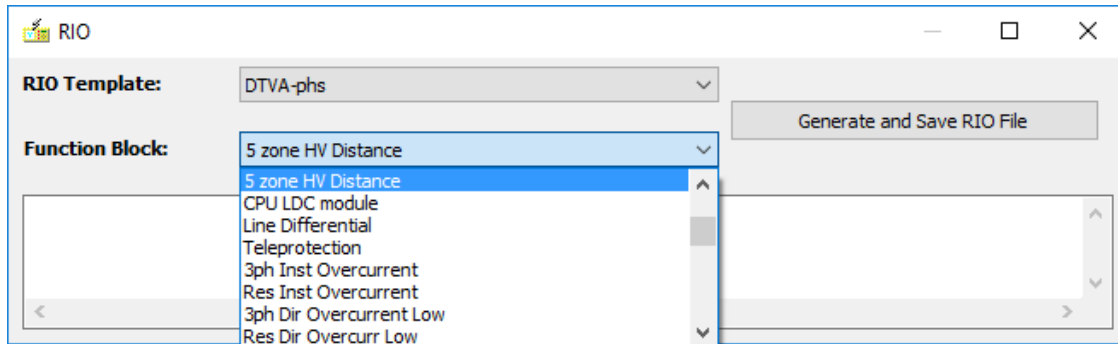

Figure 0-10 Example: RIO Template selection

When the "Generate and Save RIO file" is pressed, first the file name and location must be selected in the usual file selection dialog window, then the file is saved and the RIO window also shows the generated file. The file can be checked with a text editor but the machine coded content may be difficult for the user to understand. The test set will set the test parameters according to this information.

Please note that the generated RIO files can be used by test sets capable of UTF-16 character encoding only.

In order to further support protection device testing, Protecta offers an option with the use of XRIO files as well. These files are available for multiple function blocks and can be downloaded from the website under Downloads/EuroProt+/Software.

THE RACK DESIGNER

The "Rack designer" is an embedded software needed for assembling the hardware modules of a EuroProt+ device. A device consists of:

- a rack, the size of which is factory selected (84HP = full size, 42HP = half size)
- a front panel, the size of which is matched to the rack
- a bus panel, the size of which is matched to the rack
- several hardware modules.

The Rack designer can be opened by the  -icon from the icon bar or from the menu: Project / Rack designer... **Designing the rack**

Protecta provides factory configurations, the module arrangement of which can be changed or extended by the user. For an example, see Figure 0-1.

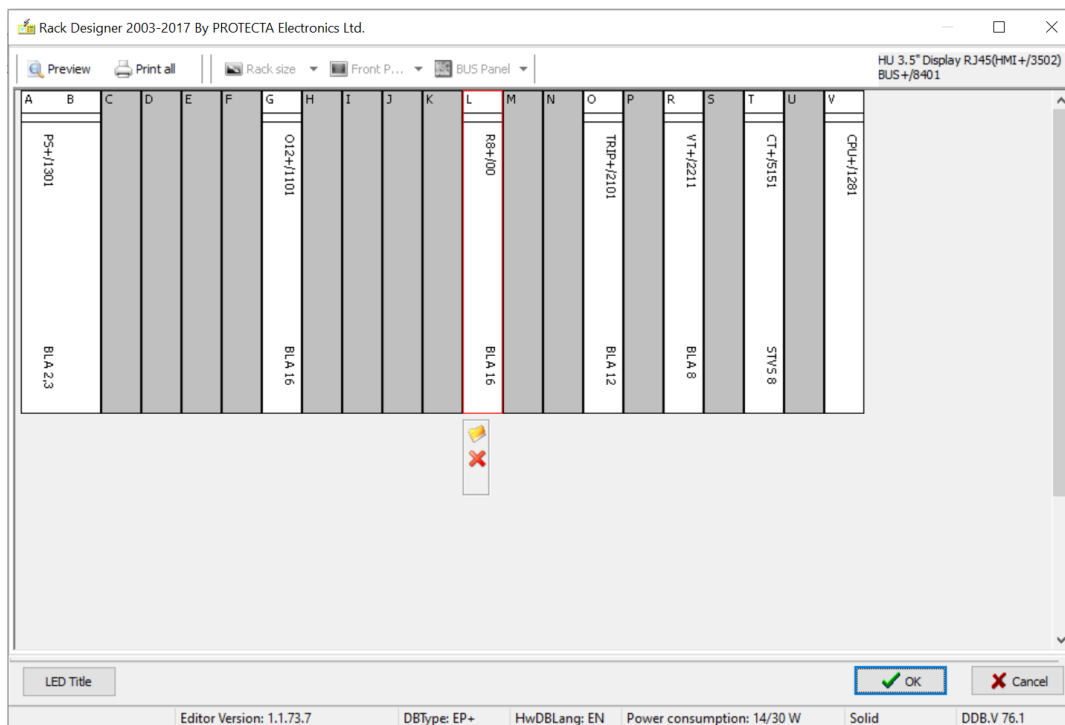

Figure 0-1 A factory configuration in the rack designer

The rack size, the type of front and BUS panel are factory selected, so these options cannot be modified by the user in Master View.

Figure 0-1, as an example, shows a “full-size” version, containing (from right to left in rear view):

- CPU module in position V
- CT input module in position T
- VT input module in position R
- Trip relay module in position O
- Signalling relay module in positions L
- Binary (optocoupler) input module in position G
- Power supply module in positions A-B
- The other slots are empty

The CPU module is always in the rightmost position in rear view (I in a half-size rack, V in a full-size rack and F in S24 devices); the power supply unit is located on the left side (positions A (and B)).

The technical details of hardware modules are described in the Hardware description; this document discusses only the selection method.

When clicking on a module or on an empty position (e.g., position C in the example), a small symbolic menu shows



the possible actions:

Here the icon  opens the module selection window, offering the main selection menu of the module type depending on the type of the module on which the user has clicked. By clicking on empty slots, binary input and binary output (signalling) modules can be selected for addition. By clicking on existing modules, only from the same type can be selected for modification. Power supply, current transformer, voltage transformer and trip modules can be modified in Master View. Note, that if the type of the CT or the VT is changed, some parameter ranges might have to be changed, as well! In these cases, please contact Protecta support!

Figure 0-2 shows, as an example, the selection of the binary output modules. Although the trip module types also appear in this window if an empty slot or a binary input/output module is chosen, trip modules cannot be added in Master View, only the type of an existing trip module can be changed.

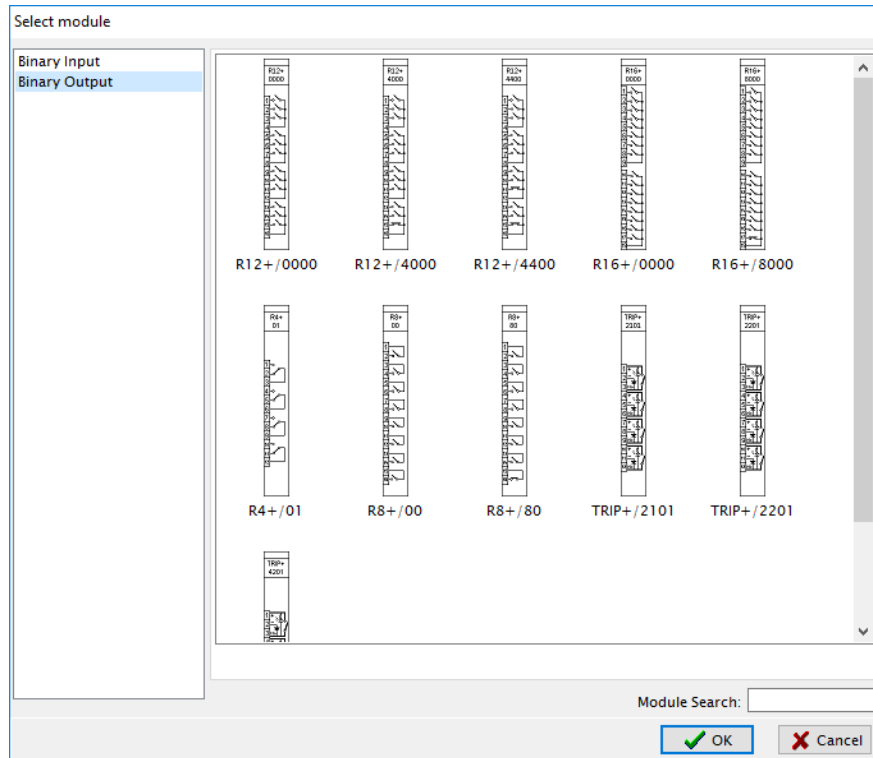



Figure 0-2 Module selection window showing the choice of the binary output modules

The user in Master View can remove binary input and output modules by the icon . If other module type is selected, a warning message will inform the user, that deleting that module is not allowed for master users. If an empty slot is chosen, this icon is greyed out showing that this function is not active. If you would like to add, change or remove a module which is not allowed in Master View, please contact Protecta support!

Selecting  Preview on the toolbar shows the arrangement familiar to the user, according to Figure 0-3. The connectors and the symbolic functions of the modules are also shown.

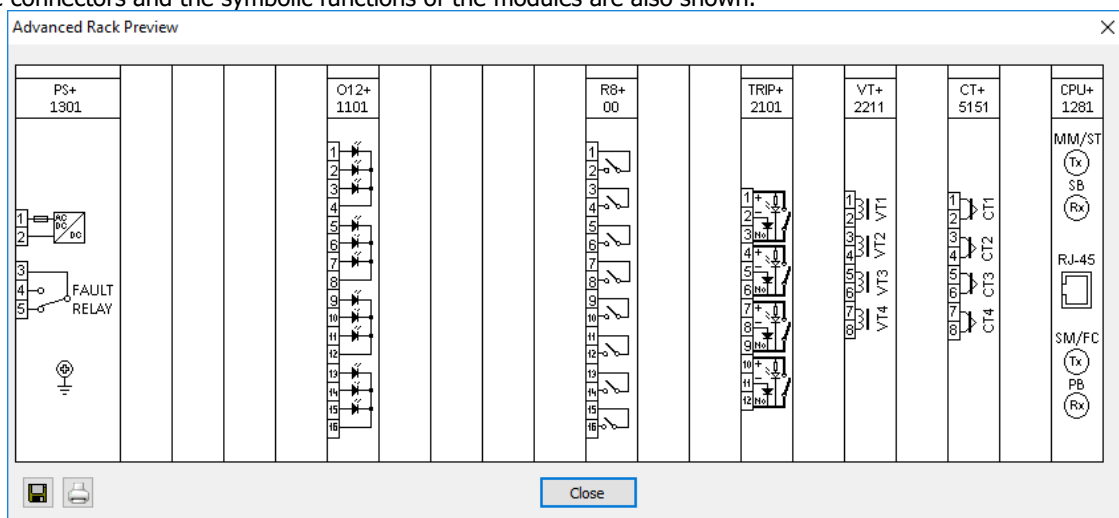

Figure 0-3 The rack preview

When the number of binary inputs or outputs of the device has been changed (because of changing, addition or removing one or more input or output module), attempting to leave the Rack designer by pressing the "OK" button (Figure 0-1), an information message is displayed.

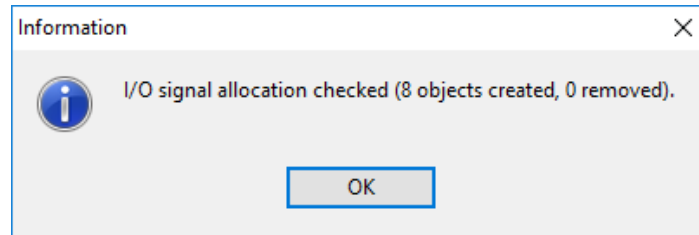

Figure 0-4 Message after adding an R8 module

The Rack designer allows modification of the LED titles for the printed front panel of the device. For this procedure press **LED Title**. The "LED title" window supports editing:

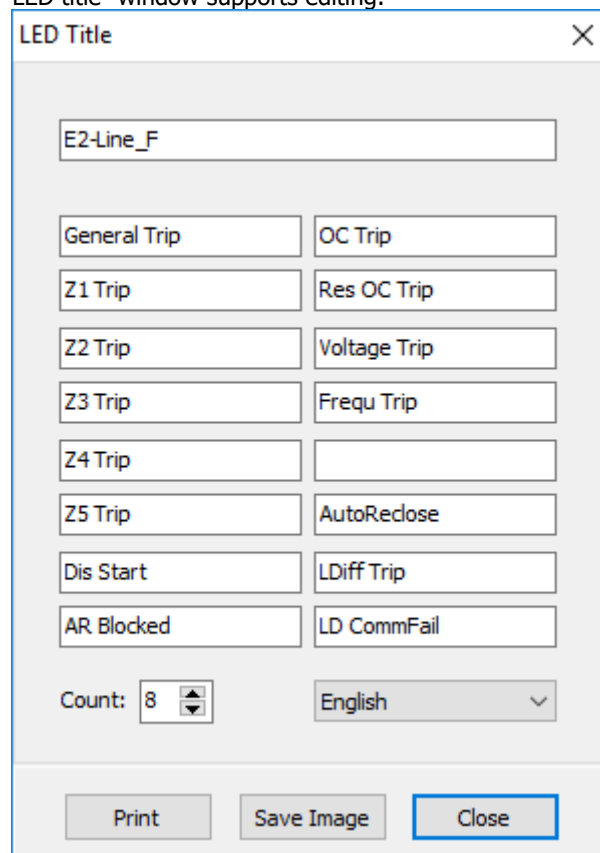

Figure 0-5 The LED text editor (Example)

You can modify the LED titles to be printed. However, these modified titles will appear only on the printed sheet and not on the mirror of the front panel on the webpage of the device! There the titles will be displayed, which are defined in the menu Hardware Configuration / LED assignment.

It is possible to set in this window the count of the LED-title pages on the A4-size sheet. The count can be between 1 and 8. The size of one LED-title page does not depend on this count, it is always the same, which fits to the pocket on the front panel.

Also, the language of the titles to be printed can be selected by the dropdown menu, if there are more translations in the configuration file.

Before printing the print preview is shown, like below:

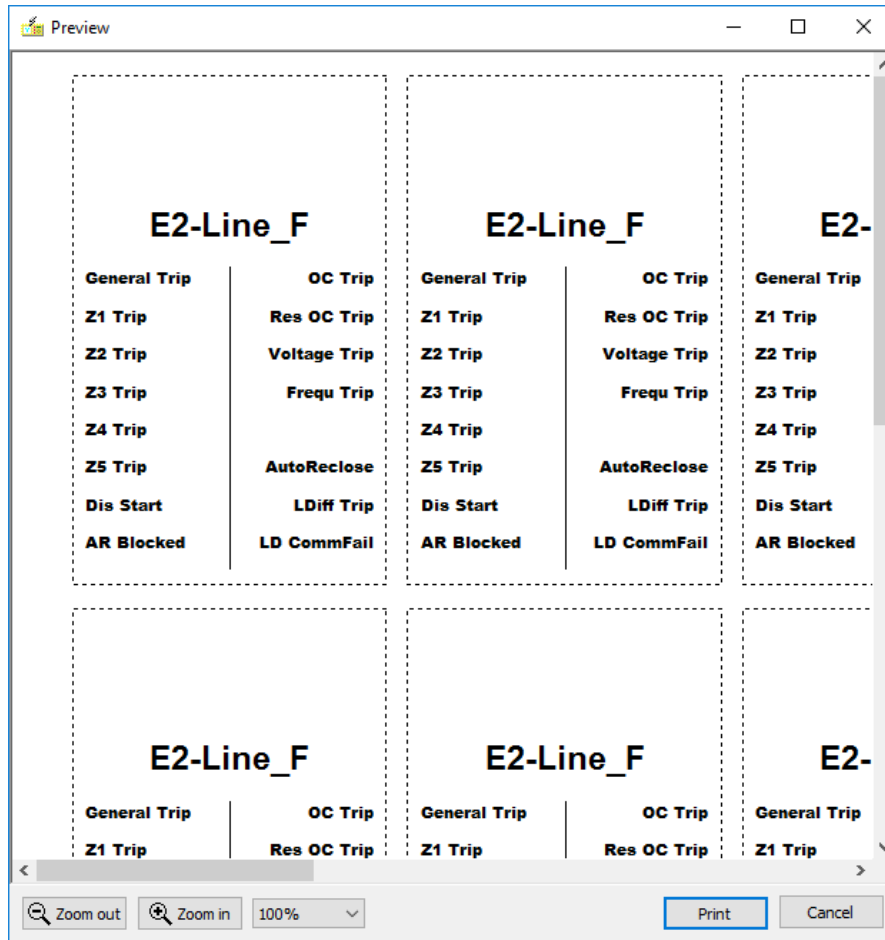

Figure 0-6 The LED-title pages print preview (Example)

The LED-title page can be also saved as image by the **Save Image** button in the LED title window. The format of the image can be .png or .bmp.

Displaying the details of the I/O signals

The details of the I/O signals can be checked in the left-side configuration menu by selecting "Connector allocation". For more details, see chapter 1.7.1.

THE GRAPHICAL LOGIC EDITOR

Application

The graphical editor is a powerful tool available for the user to compose logic equations based on the analogue and binary signals of a factory configuration.

The inputs of the logic equations can be:

- Filtered binary inputs
- Graphed input statuses
- Logic parameter variables
- Matrix columns

The outputs of the logic equations can be:

- Contacts
- Graphed output statuses

The applicable logic operators are:

- AND
- OR
- NOT

The functional objects are:

- Function blocks
- Timers
- Macros

Starting the graphical logic editor

There are two methods for starting the graphical logic editor:

- clicking the "Graphical Logic Editor" icon  on the toolbar, or
- selecting the "Project" menu item on the header, then clicking "Logic Editor". (See Figure 0-1)

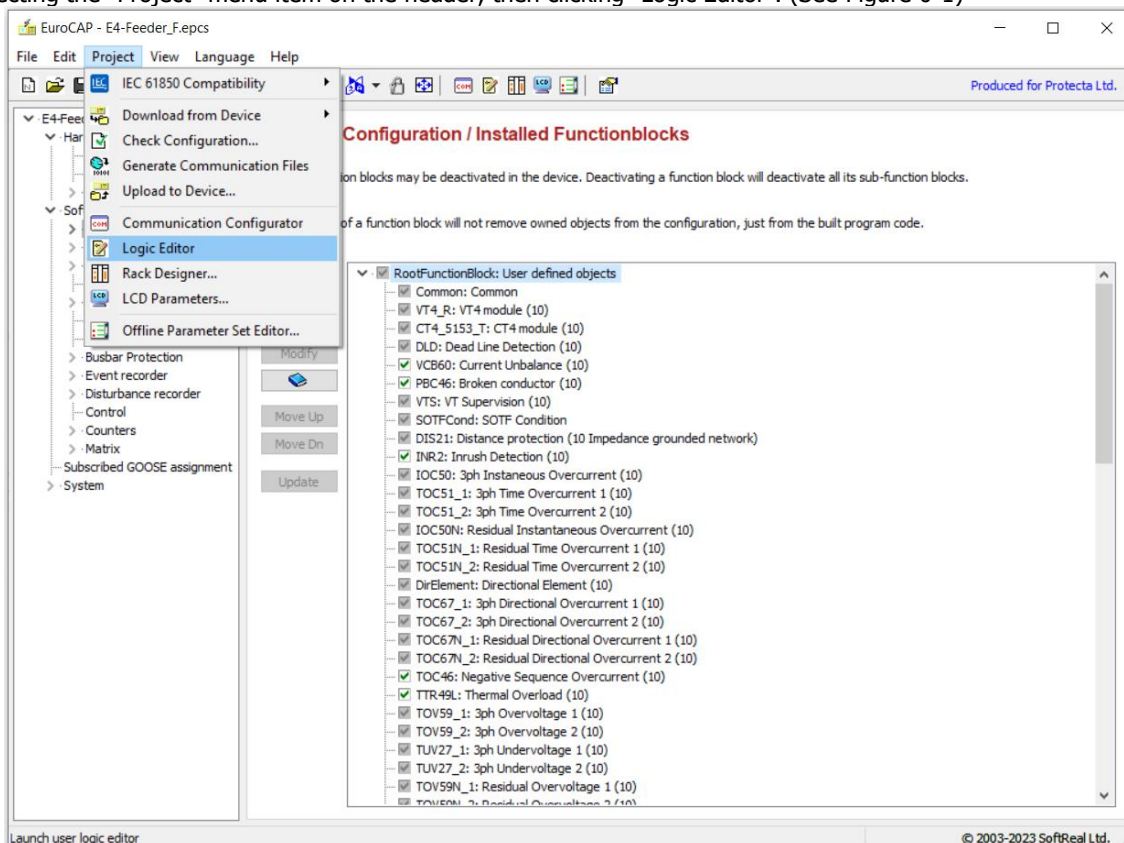

Figure 0-1 Opening the graphical logic editor

Active icons at starting the graphical logic editor

After starting the graphical logic editor, the window opens showing a drop-down menu and the icons on the toolbar. The editor is divided into "sheets", each of them contains one or more graphic equations. The names of the sheets are free to define. At the first opening, "Sheet 1" and "MACRO EDITOR" are available.

The **drop-down menu** provides a tool for selection among the sheets; Figure 0-2 shows an opened drop-down menu, using names given in the factory configuration.

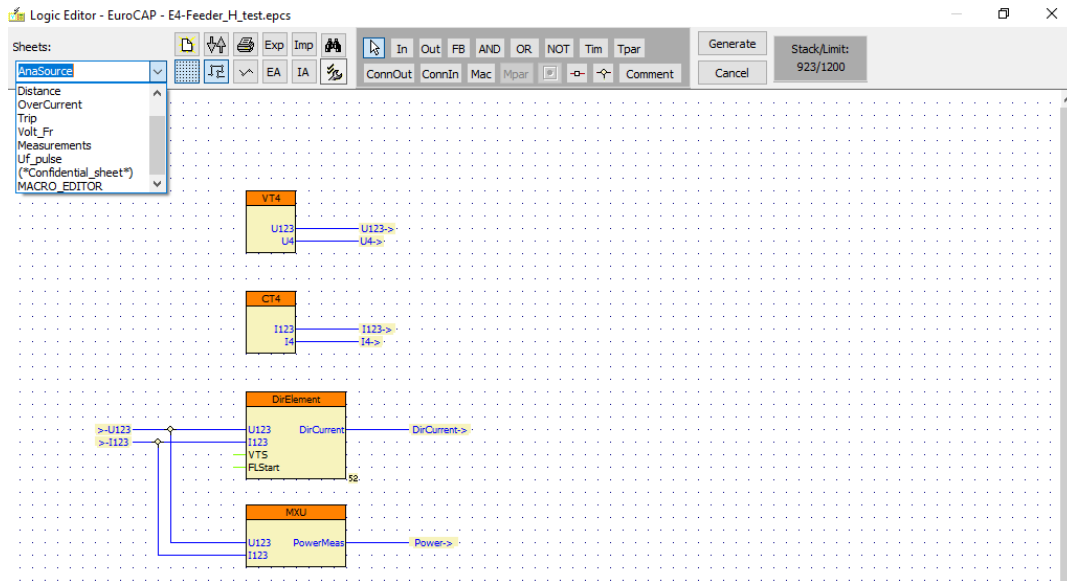















Figure 0-2 The toolbar of the graphical logic editor





NOTE: All the sheets can be opened in "Master" view except sheets that are locked in the factory. These are displayed enclosed in asterisks on the drop-down menu. See *Confidential_sheet* in Figure 0-2 above.

The **icons on the toolbar** are as follows (the details of their use are described in this chapter below):
The icons related to the sheet:

-  "New sheet" icon for adding an empty sheet to the list. A name is given automatically but it can be modified easily in the "Sheet properties" dialog.
-  This icon can change the sequence of the sheets
-  This icon is for printing the graphic equation. It opens a dialog that controls printing the way similar to any Windows-based software.
-  This icon can export and save the sheet
-  This icon can export and save all sheet
-  This icon can import a saved sheet
-  This icon can import a set of sheets
-  The properties of the sheet (colors, size, parameters for printing, etc) can be set using this icon.
-  The sheet can be viewed with or without grids; this icon serves for toggling.
-  When connecting the elements and this mode is active, only horizontal and vertical lines can be drawn.
-  When connecting the elements and this mode is active, any straight line can be drawn.
-  Icon starting the search function. The name of the last selected item is offered when launching the search window

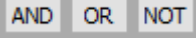
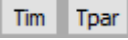
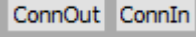
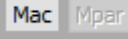
The icons symbolizing the sheet elements:

-  Using this "Selection tool," elements on the sheet can be grouped and moved as a single unit.
-  With these icons, the inputs and outputs of the graphic equation can be selected from drop-down lists.

-  The function blocks configured in the device can be placed on the sheet and the related binary inputs and outputs can be included in graphical equations.
-  Selection of simple AND, OR, NOT "gates" for processing the binary signals.
-  Selection of timers and related timer parameters for processing the binary signals.
-  These icons are used to transfer signals from one sheet to another (also within a sheet).
-  These icons serve the purpose of processing "macros" (pre-defined parts of logic equations) to simplify the most common operations.
-  Macro compilation if the MACRO_EDITOR sheet is active.
-  Icon for creating a node (a location for breaking the line) on a connecting line at the cursor location
-  Icon for creating a junction on a connecting line at the cursor location
-  Icon for inserting a text comment

The active **buttons of the toolbar**:

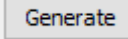
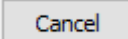
-  Using this button, the graphic equation can be checked for errors and compiled for executable format.
-  Using this button, un-compiled modifications can be rejected.

Stack/Limit monitoring:

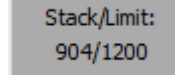
-  This icon shows the limit and the current number of the stack operation. Displaying current number of stack operation does not change during editing, only at the next opening of the Logic editor. If the stack is close within 10% of the limit or exceeds the limit, a warning message appears. This way the user logic can be generated and saved, but the upload process is disabled. The same operation applies, if a generated equation is too long. A warning message appears for every long equation to help correcting.

The detailed description below explains the application of these icons for editing logic equations in a graphical format.

Analogue signal assignment in logic editor

Starting from version 3.1.1 there is a possibility to assign analogue inputs to function blocks from the logic editor. There are now graphical representations of the voltage and current input modules which can be used to generate transferrable ConnOut signal outputs. Transferred ConnIn signals can then be assigned to protection function blocks.

NOTE: Analogue signal assignment in the logic editor requires an upgrade in device firmware to version 2.10.2.3010 and above, which supports configuration versions with this feature.

New VT & CT function blocks

Figure 0-3 below shows the voltage and current input function blocks. In newer configuration versions, these function blocks have outputs that can be used to process different analogue signals. The outputs of the function blocks are the so-called analogue sources. These analogue sources can be further split into different types depending on the application of the output. The most common as seen in the figure below is to group the first three channels and designate them three-phase voltage/current and the fourth channel as a different group, designated residual voltage/current.

Logic Editor - EuroCAP - E4-Feeder_H_test.epcs

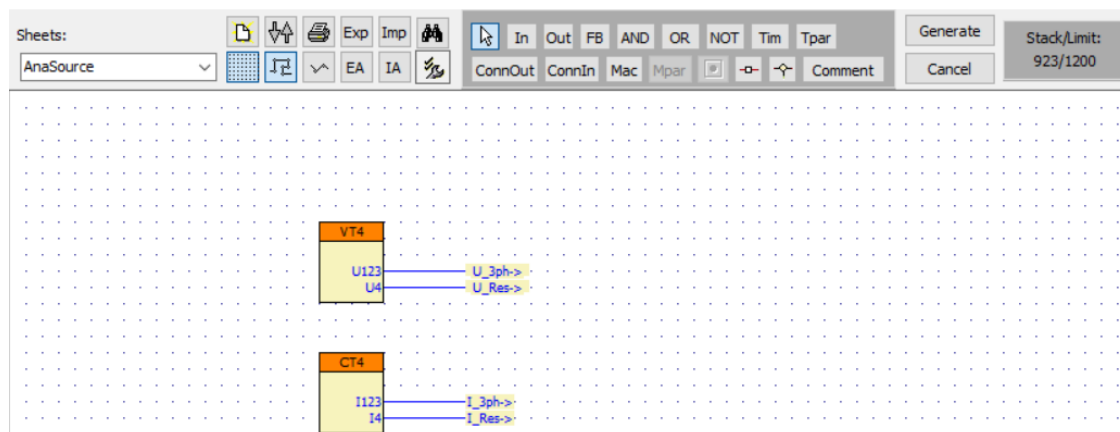

Figure 0-3 Voltage and current input modules in the logic editor

The signals from the analogue sources can be transferred to the relevant function block inputs through ConnOut objects. In Figure 0-3 above, the analogue signal sources are connected to ConnOut objects U_3ph & U_Res for voltage and I_3ph & I_Res for current.

Analogue input assignment for function blocks

The analogue source signals from the current and voltage input function blocks can be transferred to other function blocks through ConnIn objects. In newer configuration versions, protection and control function blocks have a provision for a new type of input, a graphical analogue input. In Figure 0-4 below, three-phase current analogue signal (in blue lines) is connected to overcurrent function blocks through ConnIn object I_3ph . The displayed overcurrent function blocks, the two instances of TOC51, and IOC50, have an $I123$ analogue input, where the I_3ph signal is connected. Other function blocks may have different types of analogue inputs depending on their application. All analogue inputs are displayed in blue while the binary inputs in black.

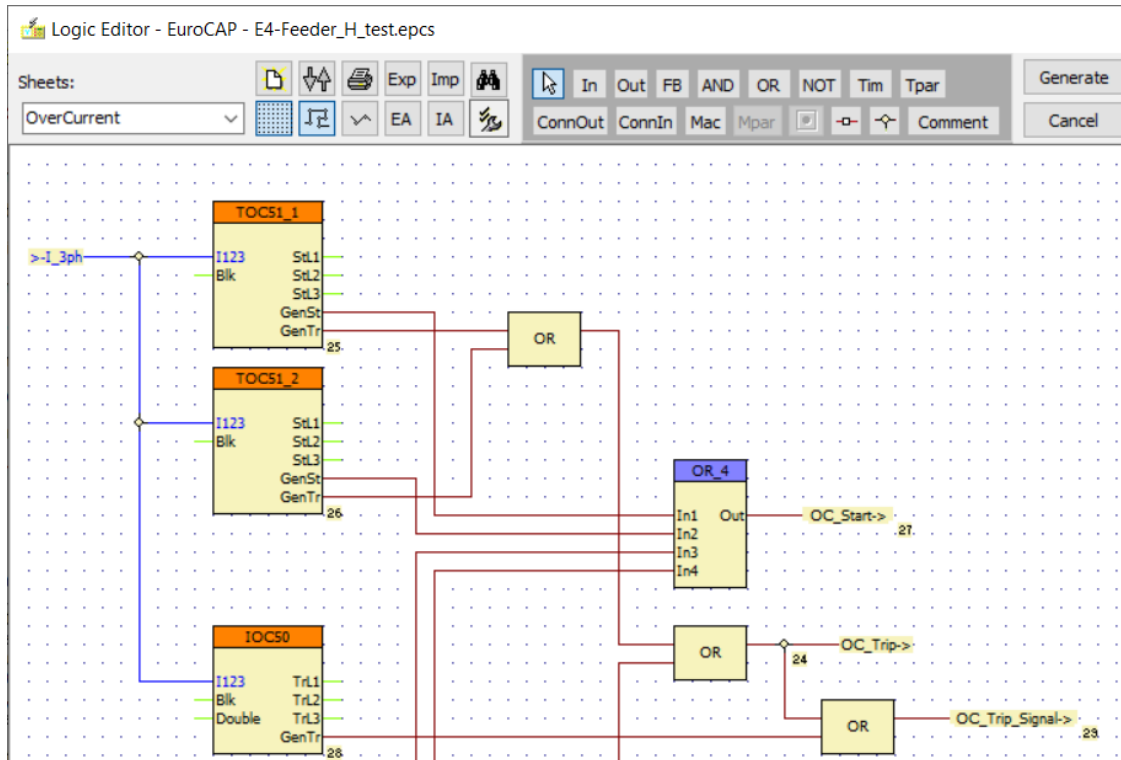

Figure 0-4 Analogue input assignment for protection function blocks

Drawing new graphical logic

The operation of the graphical logic editor is best explained through an example.



Let's compose a logic for the following task:

EXAMPLE: *The under-frequency protection function must be blocked by dead-line detection or by any of two dedicated binary inputs.*

The start signal of the under-frequency protection function must be delayed by a timer parameter, and then a pulse of a given duration must be directed to a free binary output of the device.

The proposed steps are as follows:

1. **Open a new sheet and name it "Uf_pulse".**

Using the  icon and the  icon, fill in the dialog boxes as shown in Figure 0-5. The contents of the boxes are defined by the user at his discretion.

- The left-side box of Figure 0-5 shows the definition of the sheet name, size and color on the "Sheet" tab;
- The box in the middle shows the definition of printing details;
- The right-side box shows the definition of the identifiers of the printed page.
(These definitions are not compulsory but advised.)

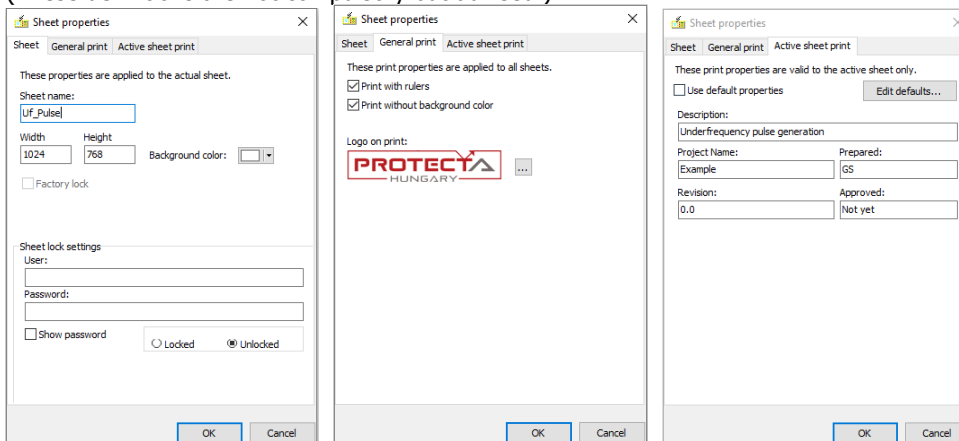



 info@microener.com +33(0)1 48 15 09 09	Configuration du logiciel EUROCAP	FDE : 23AA2420958
		Rev. : B Page 96 sur 127

Figure 0-5 Example for defining the graphic sheet

2 Place the graphic elements on the sheet:

- The required function blocks are DLD (dead-line detection) and TUF81_3. Click the icon  (Function blocks), then click on the empty sheet. A selection window is opened (showing the selection of the function block TUF81_3 according to Figure 0-6). Clicking "OK" and the block is placed on the sheet. Repeat the procedure with the function block DLD as well.

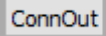
NOTE: if the desired function block cannot be found on the list, then either the configuration excludes this block (it cannot be applied) or the block is already used on some other sheets.

In the second case, use the   icons to transfer the required signal for further processing.

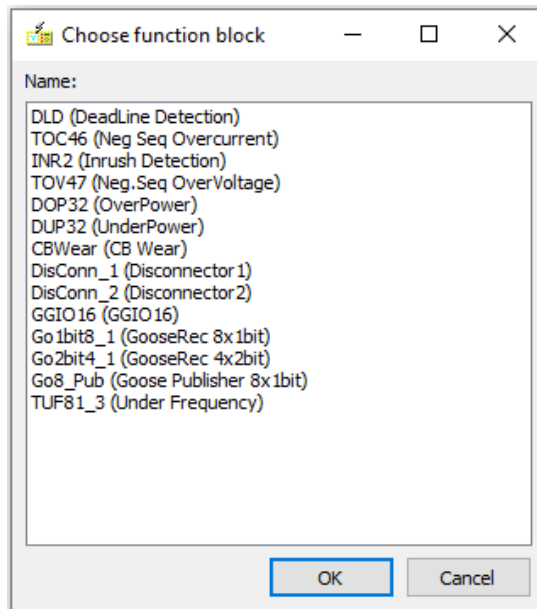



Figure 0-6 Example for FB selection

- The example needs OR connection of three signals (two binary inputs and the DLD function output). This can be achieved using two OR gates, or simply using a pre-defined macro clicking the icon , then selecting from the list of factory-defined macros according to Figure 0-7.

NOTE: See paragraph 0 below for details on macros.

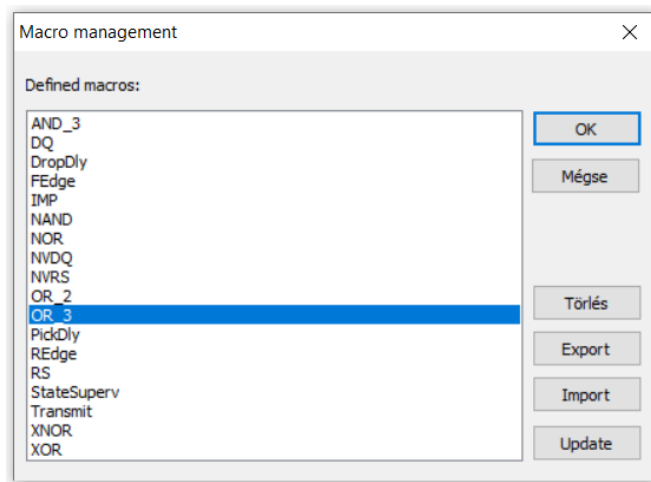



Figure 0-7 Example for macro selection

- The example needs two timers: one for the delay and one for pulse duration. This can be realized with two general purpose timers; however, it is more convenient to select the predefined macros "PickDly" for pick-up delay and "IMP" for pulse duration. (The selection method is similar to "OR_3" selection, see above.)
- The two timers need timer parameters. These are defined using the icon  (timer parameter). The window of Figure 0-8 must be filled in. This figure shows the selection of the "Variable" timer parameter. In this case, the delay is defined in a normal parameter setting session. (The "ShowOrder" information indicates the location of this parameter on the parameter list; all other information is self-explanatory.) The parameters to be defined are: "TUF_PickDelay_TPar" and "TUF_Imp_TPar".
- Using multiple function blocks or logical gates of the same type can be simplified with copy+paste commands. The recommended procedure is to use the FB or logical gate local menu (copy) by right clicking on the element. Then point the cursor on the desired location and use the right click again (paste). Keyboard command Ctrl+V is not supported.

Timer parameter

Type

Constant Variable Factory parameter

Name:

...

Title:

Default value [0 - 2000000]

ms

Minimum Value [0 - 2000000]

ms

Maximum value [1 - 2000000]

ms

Step [1 - 1000]

ms

ShowOrder [1 - 200000]

OK Cancel

Figure 0-8 Example for timer parameter selection

- The equation needs two binary inputs and one binary output. Select them using the **In Out** icon. The selected inputs are "BIn_B04" and "Bin_B06" found on the dropdown list, the selected output is "Bout_E08" (See Figure 0-9). It is also possible to put down more inputs or connector inputs at the same time with the use of Shift or Ctrl keys in the input selection and in the connector input selection windows.
- The output of this sheet can be transferred to other sheets by creating a dedicated output "TUF_Start" with the **ConnOut** icon. 'Create user status' and 'Non-volatile' attributes can also be selected for the connector outputs during the creation process in the dialog box. The output signal can be used on other sheets by clicking on the **ConnIn** button and clicking on the desired place on the sheet. A list with all available ConnOut signals will pop up and the user can select "TUF_Start". Once the ConnIn is created, its source can be easily tracked down with a right mouse click and selecting "Find source".

The result of these steps is shown in Figure 0-9. Here the icon  is depressed: the grid is visible on the sheet. The location of the elements can be altered using the drag-and-drop technique.

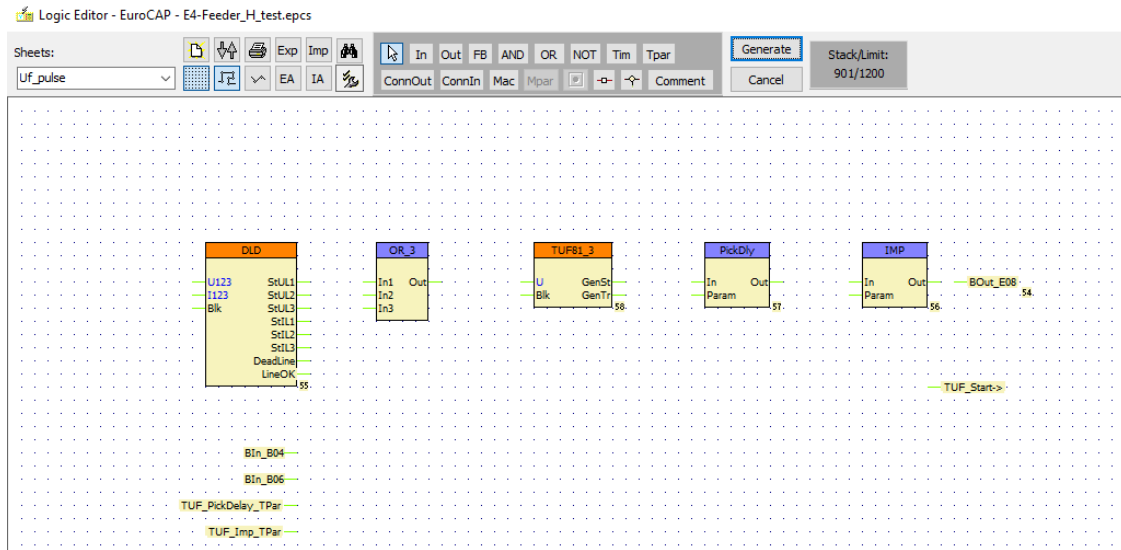

Figure 0-9 Example for placing the elements on an empty sheet

3 Draw the interconnections:

As Figure 0-9 shows, the elements placed have green connection points. Draw a line by clicking on a green start point, clicking on the required corners and clicking on the green end point. A finished line and corners can be rearranged using the drag-and-drop technique. (The line can also be deleted.)

4 Connect the analogue input signals

The analogue input signals are relevant for the two function blocks: DLD and TUF_81. Connect the necessary analogue inputs by clicking on the **ConnIn** button. On the pop-out window, select "Analogue" port type from the bottom side of the window, click on the relevant analogue signals from the top side of the window to lay the signals down on the logic editor. Repeat this process until you have all the necessary analogue signals, i.e., 2x U123 and 1x I123. Connect each signal to its respective function block input.

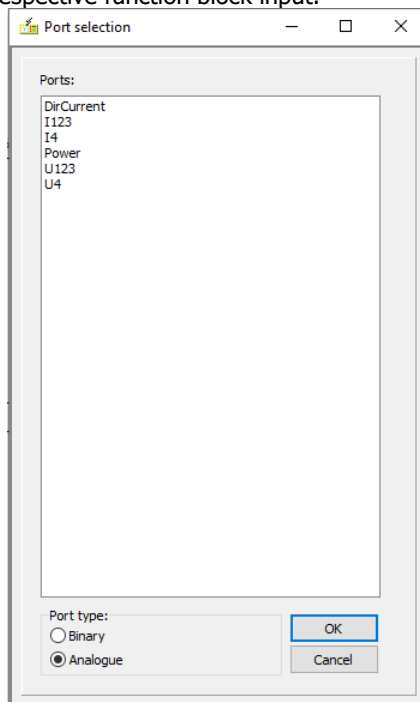

Figure 0-10 Pop out window showing analogue inputs

5 **The finished equation needs the "generation" of the executable format.**
This is done automatically when pressing the "Generate" button on the toolbar.
The result is shown in Figure 0-11 below.

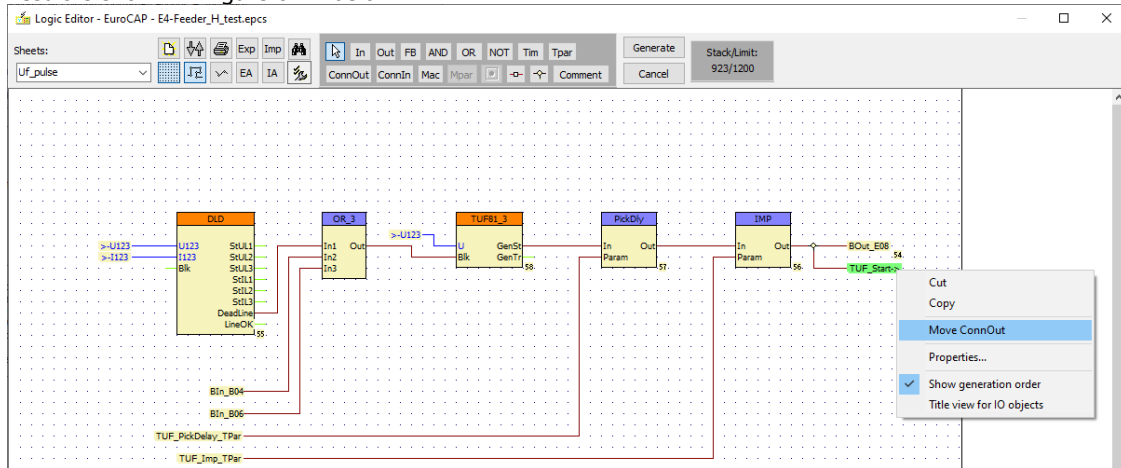

Figure 0-11 Example for a defined logic

When double-clicking on a line, a potential node point can be inserted.
When double-clicking on a node point, a junction can be inserted.
When right-clicking on a junction, the properties of the automatic new binary variable can be modified.
Connector outputs can be moved from one sheet to another. It can be done by selecting from the right click pop-up menu the "Move ConnOut" item on the source sheet (Figure 0-11) and the "Paste ConnOut item on the destination sheet".

NOTE: the small numbers at the bottom right corner of the blocks shows the processing sequence. This sequence can be modified by selecting the logical block, holding "Alt" and pressing the "Up" or "Down" arrows. The same can be done with right mouse click on the object-> "decrease" and "increase" commands. Additionally, exact sequence number definition can be done with "Set to..." User shall make sure about proper sequence numbering before clicking the "Generate" button.

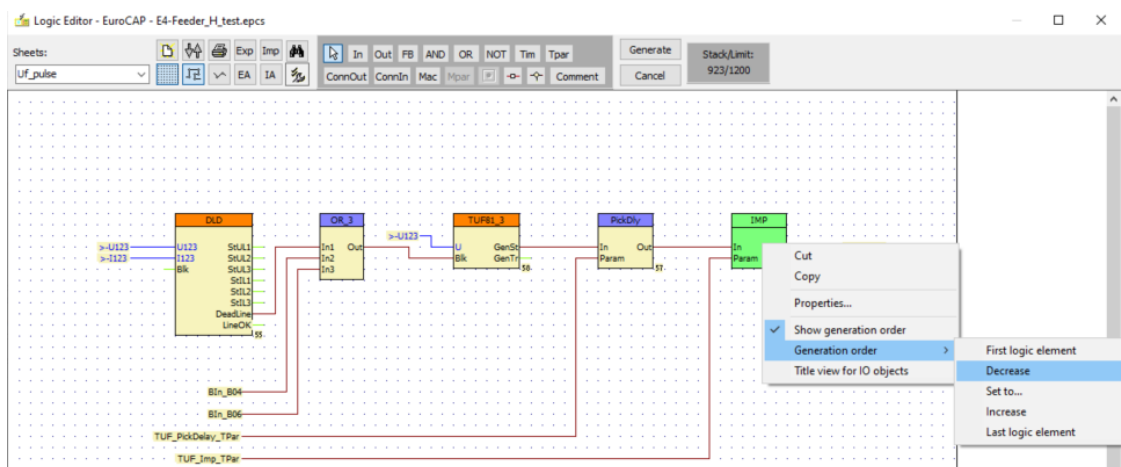



Figure 0-12 Right-click menu of an object

Printing graphic logic

The graphic equations can be printed using the  icon. The required settings for printing were made using the  icon, as shown in Figure 0-5. These settings will apply when printing the sheets (e.g. portrait/landscape arrangement).

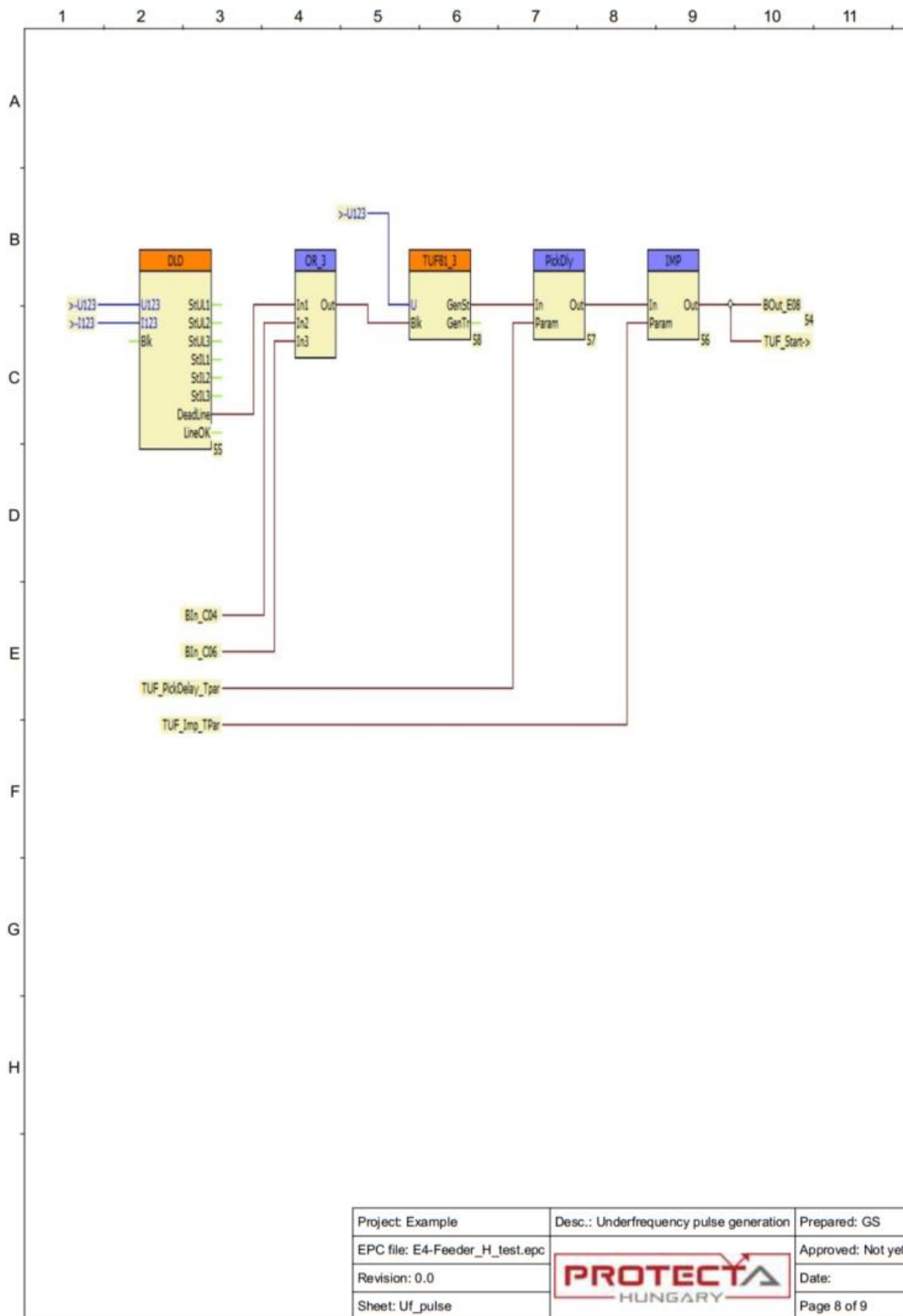

Figure 0-13 Example for a printed graphic equation

Using macros

For the most common protection tasks Protecta prepares "macros", which can be applied by the user in the graphic equations. The details are hidden from the user, which promotes the readability of the defined equations. Examples

for factory defined macros were shown in Figure 0-7. Additionally, basic logical blocks like AND/OR gates are available with up to 8 inputs in the basic factory configuration. The details of macros are described below.

Macro definition and modification

Figure 0-15 shows, as an example, the macro for impulse generation. These details can be seen if the "MACRO_EDITOR" sheet is selected in the dropdown menu of the graphic editor's toolbar. The primary purpose of this sheet is to create new or to edit existing macros. When the new macro is completed, it shall be saved and not stored on the "MACRO_EDITOR" sheet. If there is a graphic equation here, it is advisable to delete it. When right-clicking on the empty "MACRO_EDITOR" sheet, a dialog appears, see Figure 0-14.

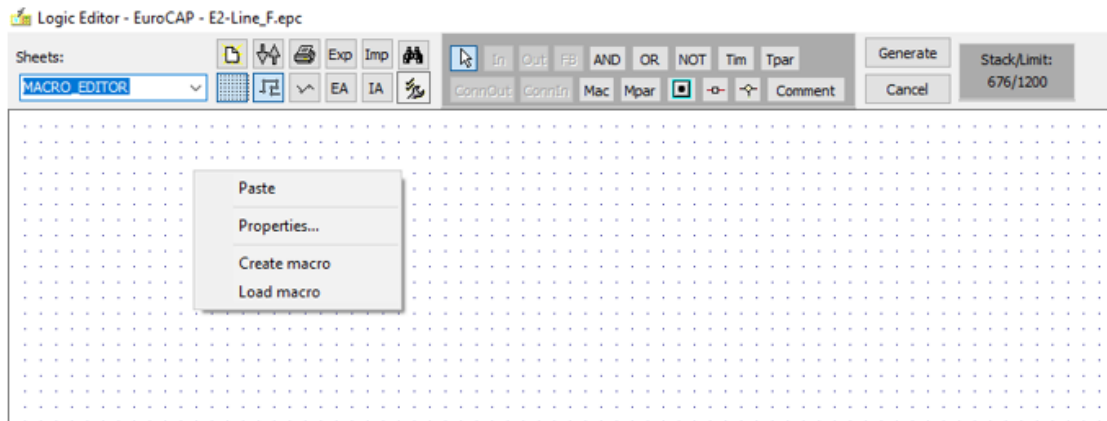



Figure 0-14 The MACRO_EDITOR sheet

Here:

- Paste (any details marked elsewhere with the selection tool  can be pasted here)
- Properties are similar to those described in connection to Figure 0-5
- Create macro a new macro can be defined
- Load macro the details of an existing macro can be viewed and edited.

When "Load macro" is selected, a list of the existing macros can be seen and any of them can be selected. In our example the "IMP" macro is shown.

The short explanation of the IMP macro:

The Macro has two inputs ("In" and "Param") and one output ("Out"). These connection points can be created with the  icon.

The timer is a "general" timer, selected by the  icon. In this case it is called IMP. (This timer can be started by several inputs, the "Running", "Expired" or "Stopped" state can be used for further processing, timer parameter can be assigned, it can be named, etc.) For pulse generation, the "Start if Stopped" input is used for starting, and the "Stop" input is used for stopping. The stop condition is that the input starting signal is FALSE, AND the timer is "Expired". The output is the running state, the duration of which is defined by the parameter. During the running state it cannot be restarted, and the expired state is not sufficient to reset in "Stopped" state if the input signal is still active.

The application of this impulse timer is demonstrated in Figure 0-11.

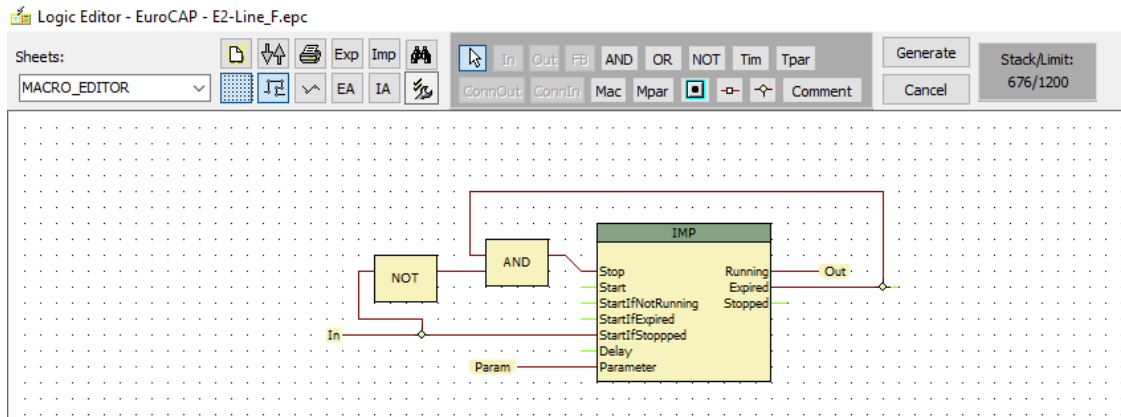



Figure 0-15 Example of a factory-defined macro for impulse generation

The edited macro must be tested for syntactic error and “compiled” using the  icon. (The same procedure can be started by right-clicking on the sheet and selecting the “Create macro” menu item.) For compilation, the graph to be compiled needs to be marked using the selection tool . See Figure 0-16.

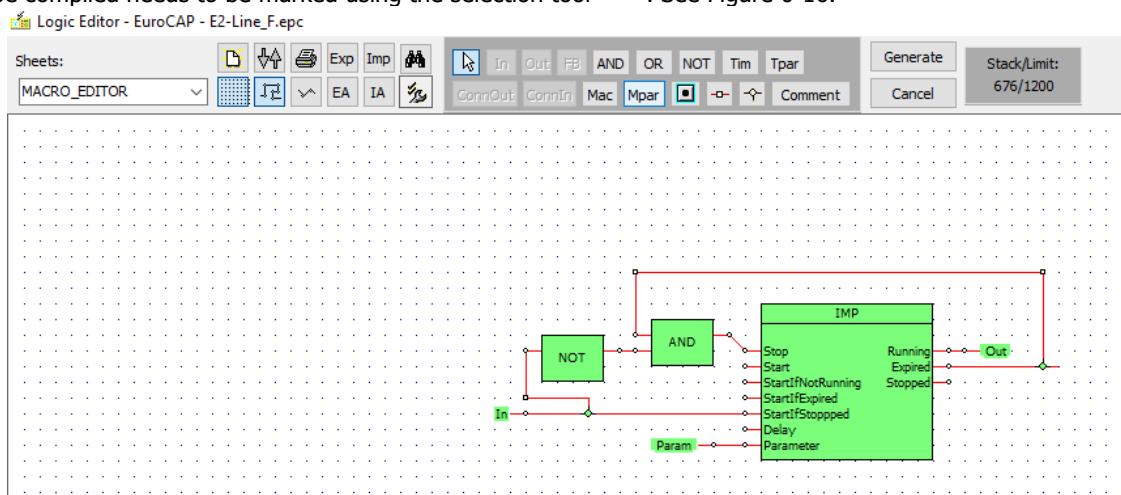



Figure 0-16 Selection a macro for “compilation”

During compilation, a special window is opened, as seen in Figure 0-17.

Figure 0-17 Macro “compilation”

The macro must be named in the “Macro name” dialog box, then the “OK” button is to be pressed for compilation. As a result, the macro can be found on the list of the available macros when the icon  is selected on a sheet.

Managing Macros

In the Macro management window (Figure 0-7) the user can execute multiple operations with compiled macros. "Export" means saving the selected macro in a file for application in other configurations, while "Import" means that a ready-made macro stored in a file can be imported to the active configuration's list of available macros. It is also possible to update the available macro list based on a selected folder which contains macros. Unused macros will be updated, while new macros will be loaded after clicking the "Update" button and selecting the intended folder. The edited and imported macros must be generated by clicking on the "Generate" button on the toolbar, and then saved in the configuration file. The location of this file is shown on the figure below.

NOTE: the indicated location needs to contain a folder named "Macros" to export the generated macros. If it is missing, please generate it manually.

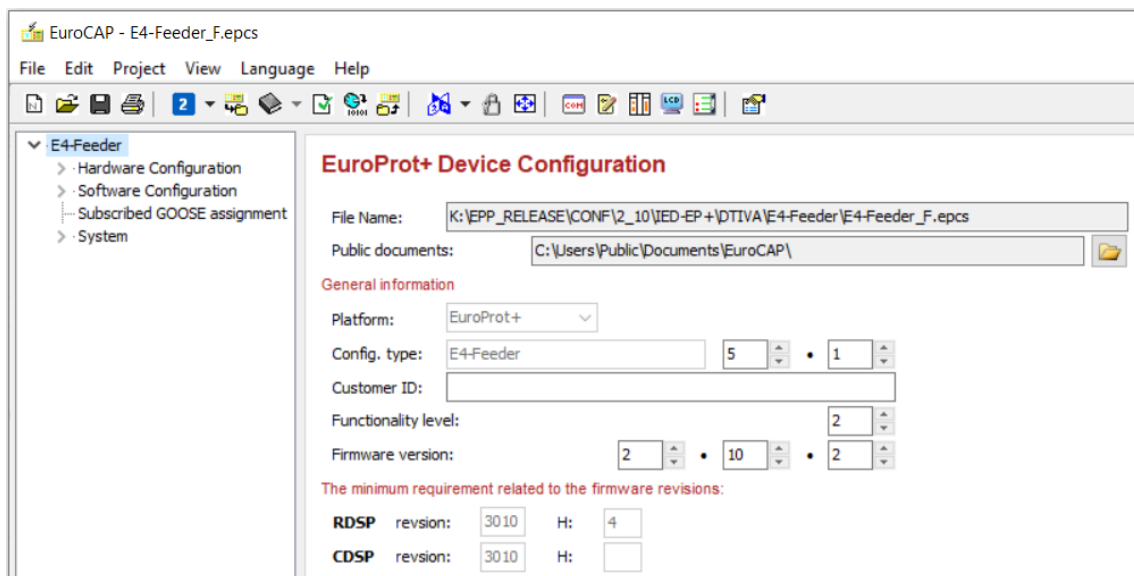

Figure 0-18 Path for saving the .epc/ .epcs file

Logical sheet export/import

The paragraphs of this chapter describe the logical sheet export/import process in the Logic Editor tool of the EuroCAP configuration software.

Sheet export

Every sheet can be exported individually by the  button as an .sht file.

Export all sheets

The  button can be used for the all sheets export. The exported file format is Multi sheet files (.sheets file extension). This feature can be launched from the EuroCAP software version 1.5.1.10 and higher.

Sheet import

The import button  can be used for importing the previously saved logical sheets (.sht file extension).

NOTE: If an active sheet is being modified and a new sheet needs to be imported, the modified graphical logic on the active sheet has to be generated first. Then the import process can start. By not following this procedure, the EuroCAP will notify the user. This message (Figure 0-19) can be acknowledged by clicking the "OK" button.

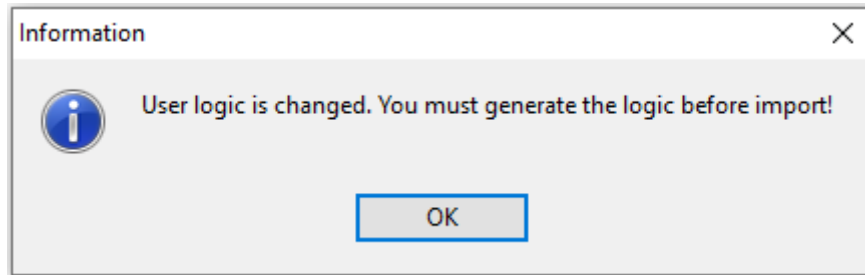

Figure 0-19 Information window related to the sheet import

NOTE: The imported sheet will be inserted before the active sheet in the sheet order.

The following warning/information messages can possibly pop-up during the sheet import process:
If you see the message which is written in the Figure 0-20 or Figure 0-21 and press the „OK” button, the import process is interrupted.

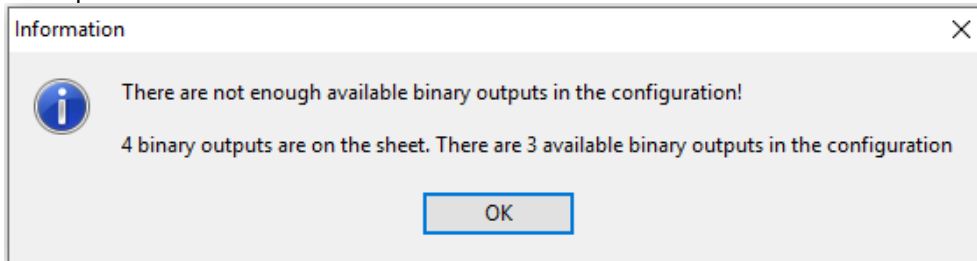

Figure 0-20 Information window related to the sheet import

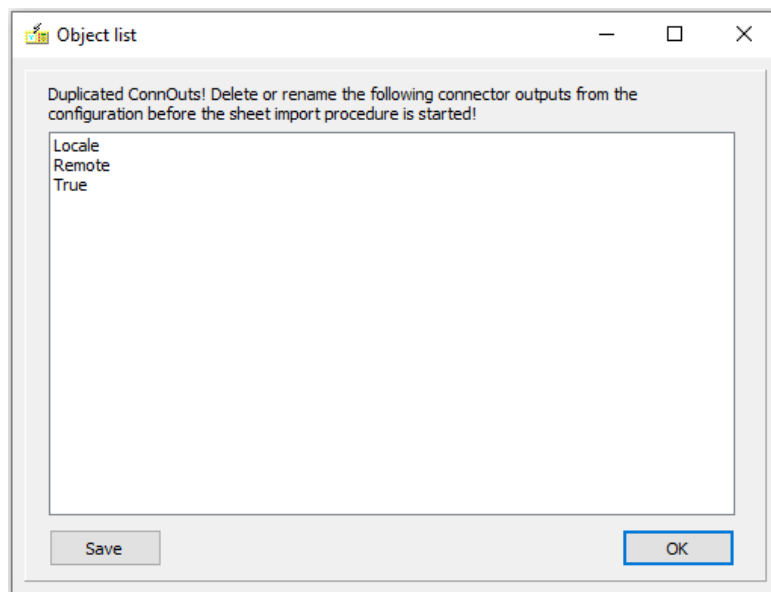

Figure 0-21 "Duplication ConnOuts!" pop-up window

The following window (Figure 0-22) is displayed if the name of the required imported sheet and the name of one sheet in the configuration are the same. In this case the imported sheet must be renamed before clicking the "OK" button.

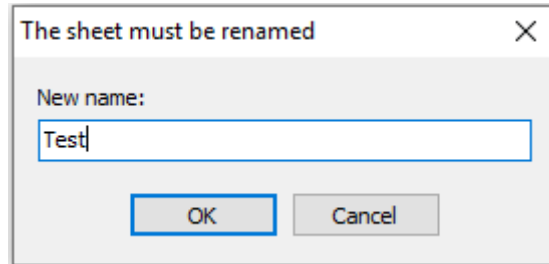

Figure 0-22 Pop-up window during the sheet import

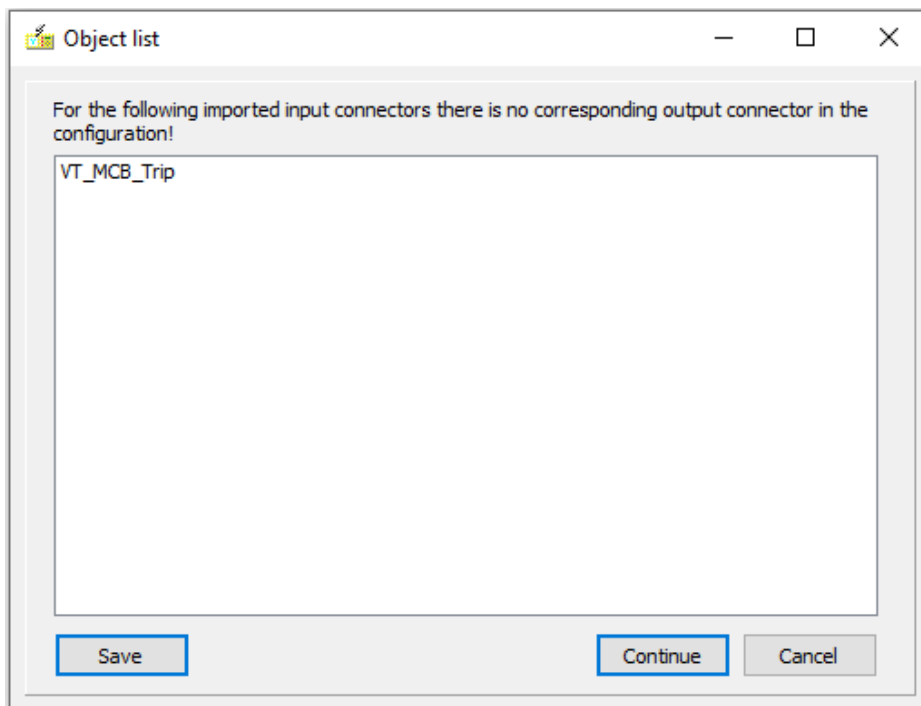

Figure 0-23 Message window while the sheet import

Figure 0-23 shows the list of the connector inputs which have no corresponding output connectors in the current configuration. It can be exported to file by clicking the "Save" button.

The following situation can be met if the required imported function block is deactivated or not defined in the configuration, as shown in Figure 0-24. The list of the function blocks can be exported to file by the „Save" button. If "OK" button is selected the import process is interrupted.

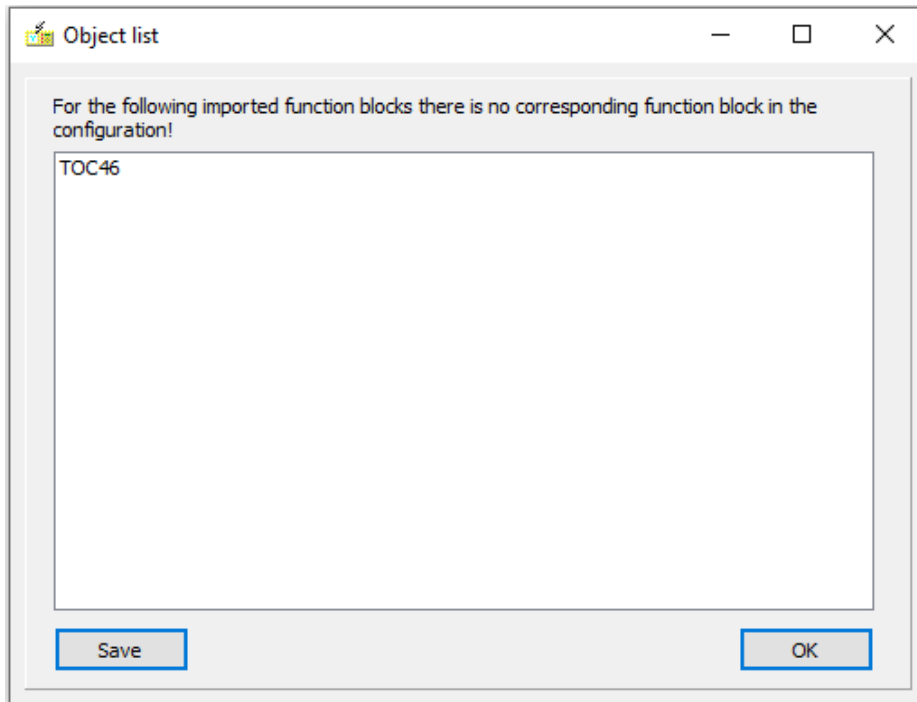

Figure 0-24 Message window concerning to the sheet import process

Matching during the sheet import process

If there are function blocks, binary inputs, connector inputs or matrix columns on the required imported sheet the following pop-up windows can be seen during the import process.

The EuroCAP software pre-matches the function block pairs automatically but the user can reassign them, see Figure 0-25 below.

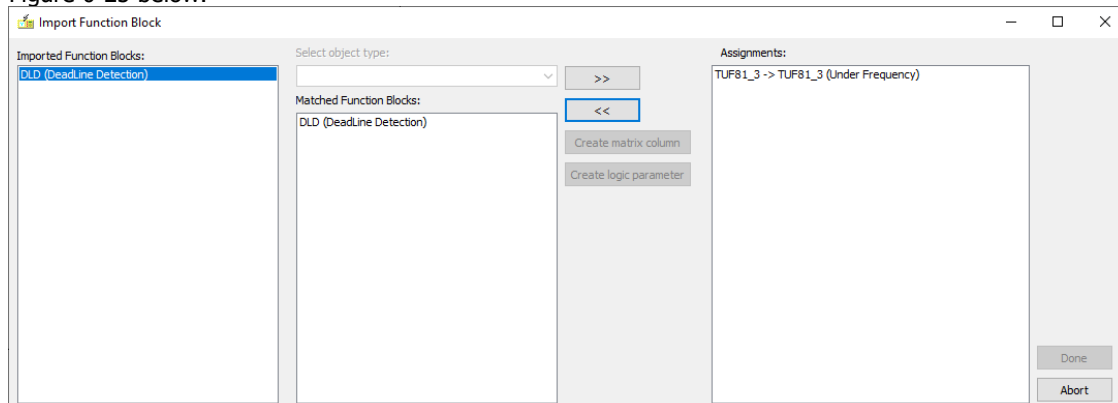
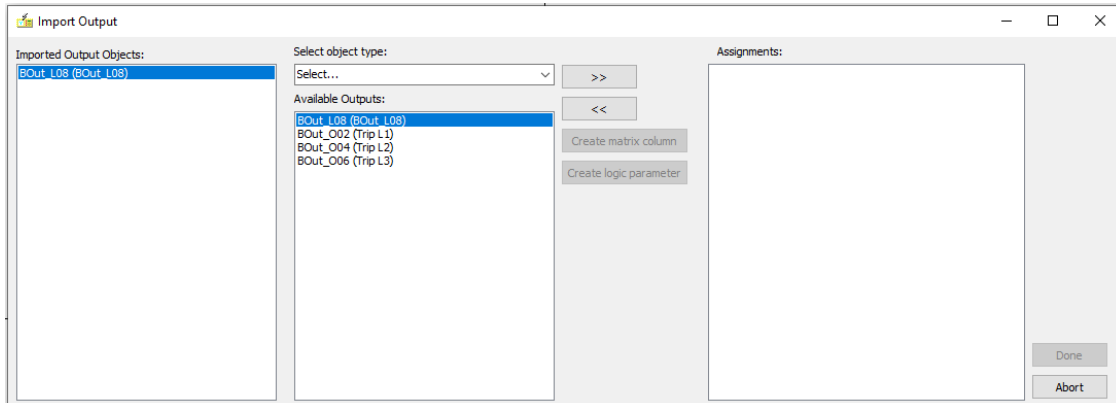
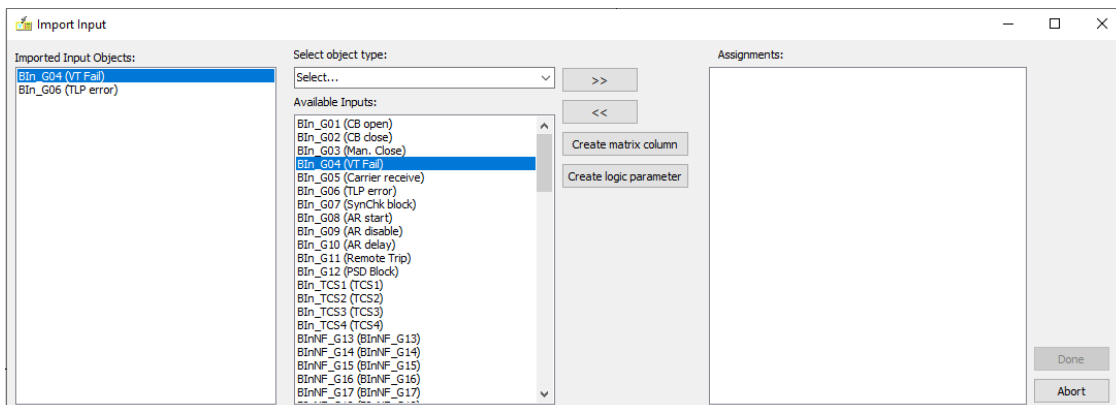

Figure 0-25 Import Function Block

There is a possibility to create matrix column or logic parameter for the imported Binary inputs or the matrix columns, see Figure 0-26 and Figure 0-27 below.

*Figure 0-26 Import Binary input**Figure 0-27 Import Matrix column*

If new matrix column or logic parameter shall be created and there is matrix column with the same name in the configuration then the following message will be generated.

*Figure 0-28 Error message during the matrix column assignment*

The Figure 0-29 is related to the matching of the connector input. Here there are listed all connector inputs, which are on the imported sheet.

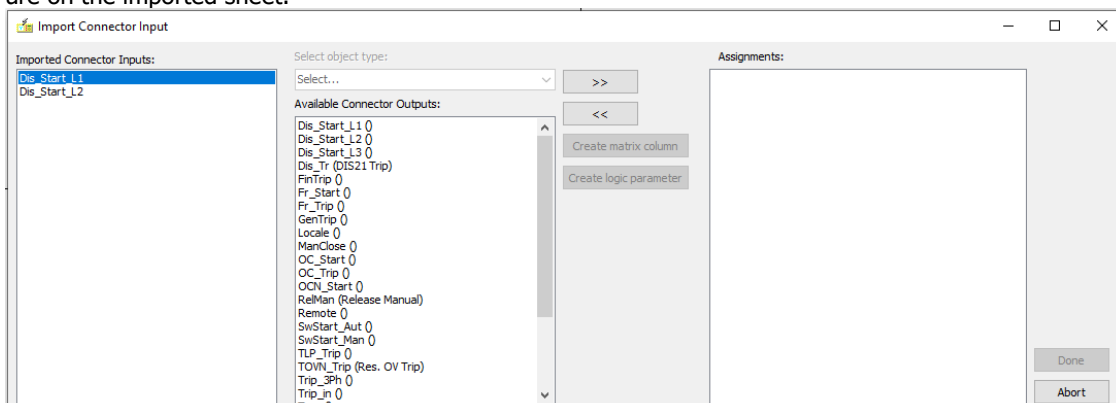



Figure 0-29 Import Connector input

NOTE: Anytime if clicking the "Abort" button during the assignment then the sheet import process will be interrupted.

Import all sheets

The  button is for the all sheets import from another configuration. The applied file format is the Multi sheet files (.sheets). This feature can be launched from the EuroCAP software version 1.5.1.10 and higher.

NOTE: If the "all sheets import" option is selected the current logical sheets will be changed to the imported sheets. The following warning message informs the user about it before the all sheet import.

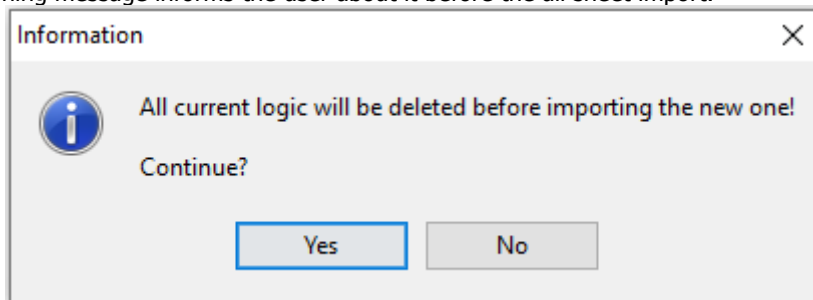
*Figure 0-30 Information window related to the all sheet import*

NOTE: During the all sheet import process the deactivated FBs are activated in the configuration automatically which are used on the imported sheets.

If the required imported function blocks, matrix or binary inputs are missing in the current configuration you will get the following information window (see Figure 0-31).

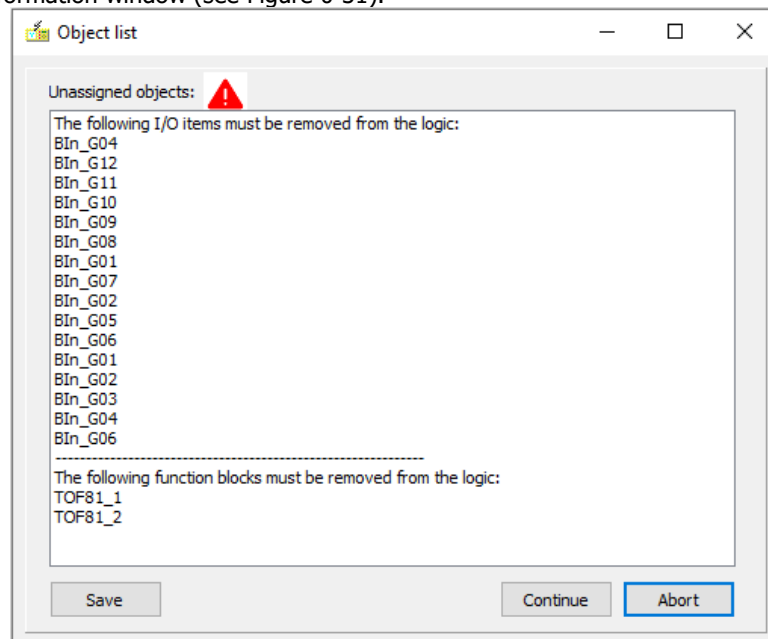
*Figure 0-31 Information message during the all sheet import process***Setting DOI descriptions for IEC 61850 Logical Nodes**

When a Function Block owns one or more IEC 61850 Logical Nodes then you can set the description of the contained Data Objects by right clicking on the symbol of the function block.

The DOI descriptions can be automatically filled for *GGIO16, and **GO8_Pub function blocks, if the connected signals' title fields are filled. The text in the title will be copied to the DOI description. If the titles change, simply click Refresh to update the DOI descriptions.

**GGIO16 (16Ch Event) – function block for creating user-defined events*

***Go8_Pub (GOOSE Publisher 8x 1bit) – function block for GOOSE signal publishing*

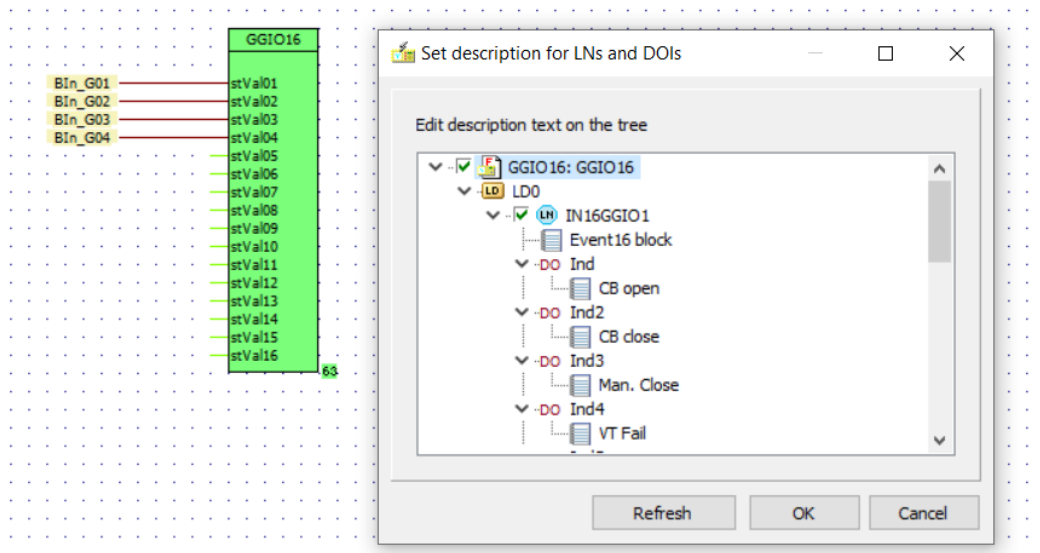



Figure 0-32 Set description for LNs and DOIs in Logic Editor

EUROCAP COMMUNICATION CONFIGURATOR

Overview

The EuroProt+ device supports several communication protocols. Modbus and SPA protocols are "self-configuring" that means the data points are fixed to the event channels of the device. The list of available objects can be found on the web interface (Advanced – Status/Log – Communication files). Other protocols need application engineering, they have specific configuration sheet in the communication configuration tool. This chapter contains information about this software. For more information about the communication protocols please read the corresponding standard's documentation.

The communication configuration software is integrated into the EuroCAP and can be started by clicking the  button on the header of the main display. The alternative method of opening the configuration communicator is to select "Project / Communication Configurator" from the menu.

There are four different sheets that can be selected: IEC 61850, IEC 60870-5-101/104, IEC 60870-5-103 and DNP3. Every sheet is divided into two main panels:

- the left panel displays the objects' overview, the tree of the available data of the current configuration,
- the panel on the right side usually contains the properties of the selected object, optionally lists the selected dataset (only IEC 61850)

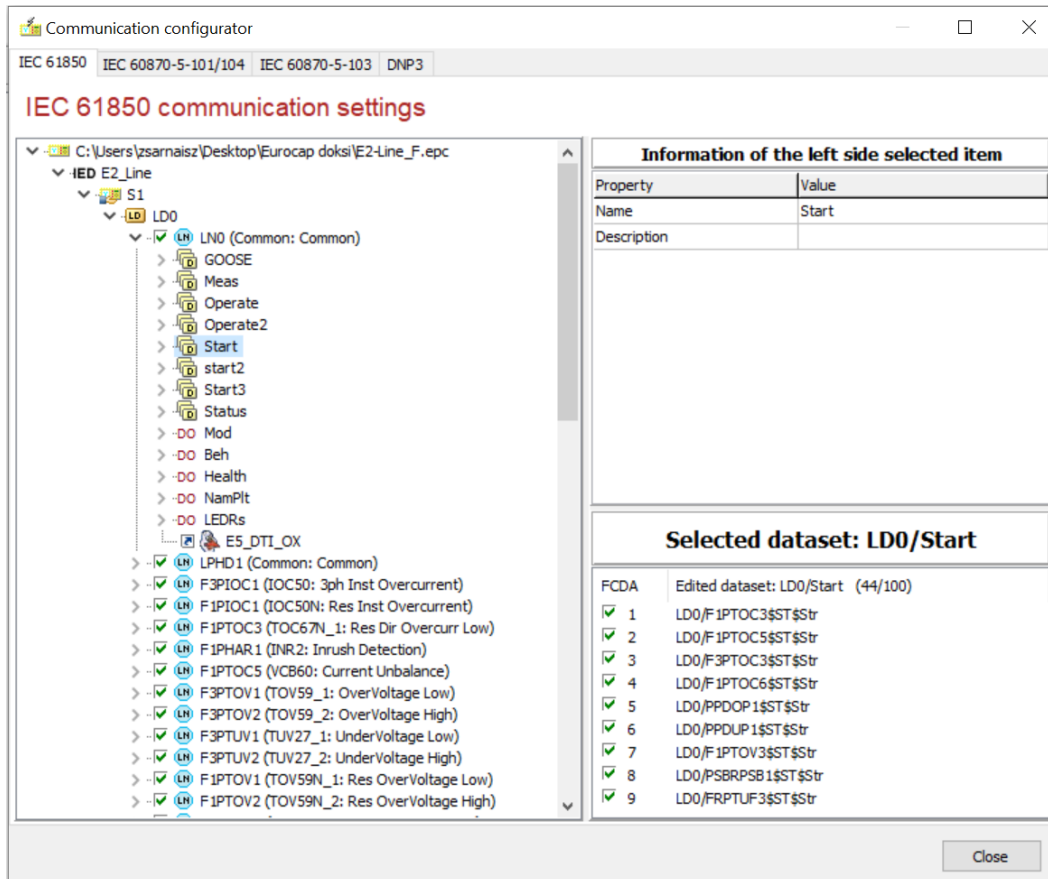

Figure 0-1 Main view of communication configuration

The behaviour of the tree depends on the characteristic of the specific protocol. Detailed description can be found in the following chapters.

IEC 61850

The EuroProt+ family is a native IEC 61850 platform, which means that this new communication standard was a fundamental consideration during the development. There is no protocol converter implemented but all the function blocks contain the logical nodes necessary for correct data modelling. This data model is factory-defined and cannot be changed by the master user. Datasets and control blocks are available for customization.

Export to and import from the system integrator

The factory default configuration contains the logical nodes describing the data model as well as the default datasets and report control blocks. A maximum of four datasets with the report control blocks are created by default, depending on the data model of the configuration. Those datasets contain the most important data object (protection start and operate signals, statuses and measurands). If this default arrangement is acceptable for the user, then no further communication engineering is needed. Otherwise, if customization is needed, the IEC 61850 configurator serves as an advanced engineering tool.

An ICD file for a system integrator is automatically generated together with the other run-time files by clicking "Generate communication files" see Paragraph 0. The generated ICD and CID files contain also those DOIs which have a description. CID file does not contain the IP address of the IED.

An SCD file from the system integrator can also be imported by using the Import/IED Description menu.

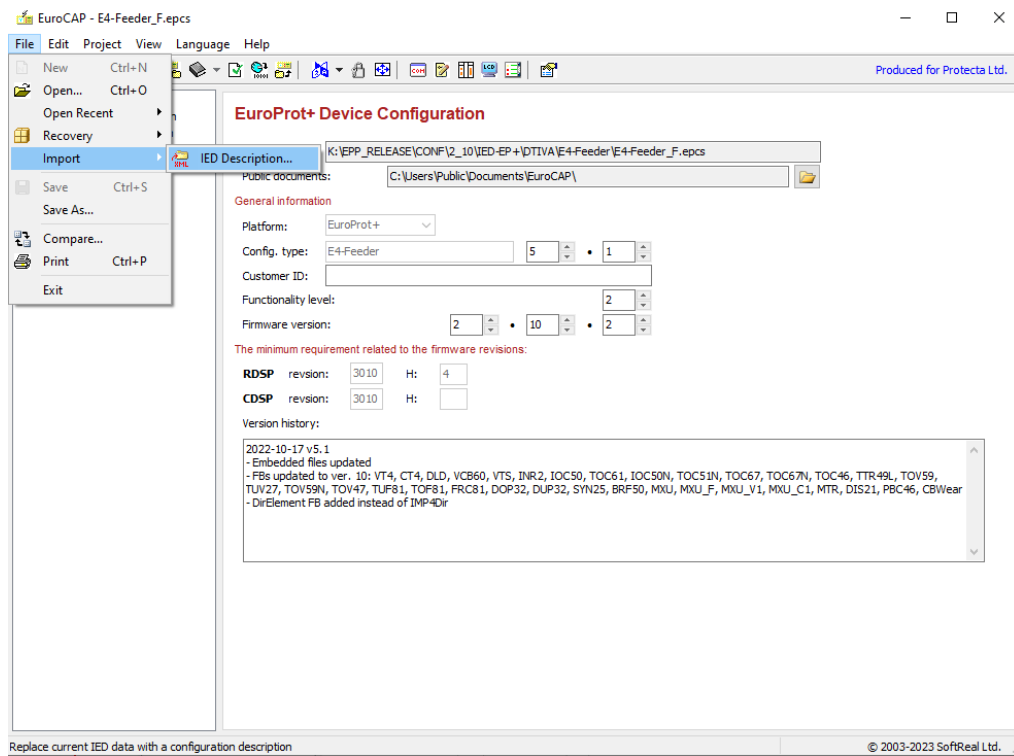

Figure 0-2 Importing IED description

Once an SCD file is selected, EuroCAP searches out the Protecta devices in it and it shows the list of the names of these IEDs. The user must select the IED corresponding to the configuration. The IEC 61850 configuration is updated according to the imported information. If the data model of the configuration and the imported IED do not match, an error message is given and no update is carried out.

The details of the last imported IEC 61850 IED description (.scd or .cid) file are displayed as the property of the root tree node (the .epc / .epcs file).

Logical nodes

The configuration-dependent list of logical nodes and DOIs can be found in the "IEC 61850 Data Attributes" column of Event recorder. User can check a Logical Node belongs to which Event of a function block.

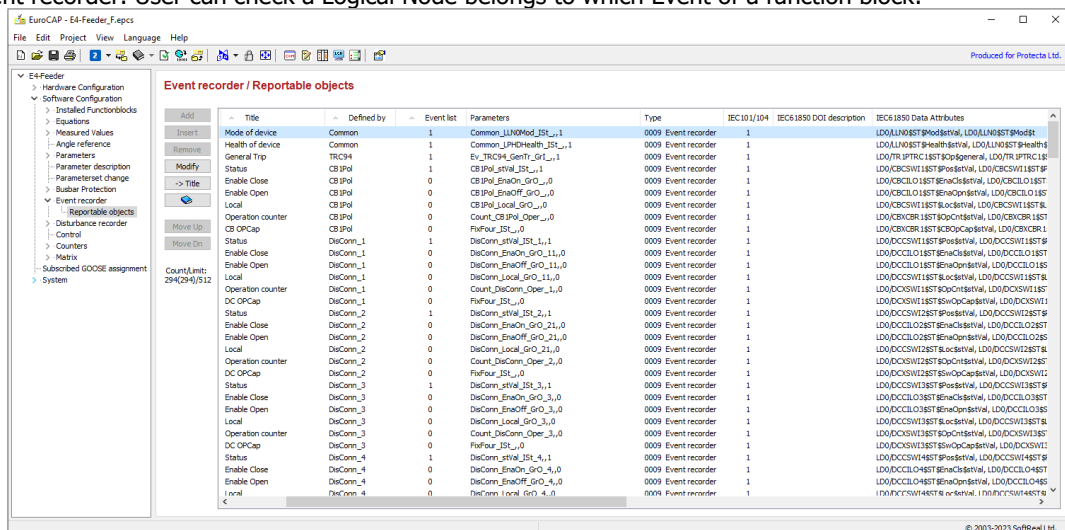

Figure 0-3 List of logical nodes and DOIs in the Event list

The "Defined by" column shows the owner of the function block designation of the corresponding logical node.

The relation between logical nodes and function blocks is also included in the IEC 61850 communication configurator in the logical node names.

IEC 61850 configuration

IEC 61850 systems need system integration process. Its result is a system description (SCD) file which contains the modified data model with configured reports and datasets. It is possible to import this file to EuroCAP configuration, see Paragraph 0. This is the preferred way of the IEC 61850 communication configuration. However, for any reason, it is also possible to do it manually. This chapter describes the manual way of configuration.

The EuroProt+ device is supplied with a default IEC 61850 configuration. The functional logical nodes cannot be changed by the user, they are "hardwired" to the device's function blocks. There is a limited access to the LN's name, prefix and suffix which can be changed (see Paragraph 0)

The integrated communication configuration software of the EuroCAP grants the user to change the remaining part of the data model: the IED name, the structure of logical devices, the datasets and reports.

The data model

The root of the tree is the name of the configuration file (see Figure 0-1). It always contains a single node, the IED device itself. By clicking on it the right panel opens its property editor. The values displayed are general information about the device and important limits regarding the reporting configuration.

The IED Name must start with an alphabetic character, numbers are not allowed.

Next object is the access point (S1) which is shown only for keeping compatibility with the standard, its name cannot be changed.

Logical Devices LD0

Next level is for the logical devices. Theoretically unlimited number of logical devices are possible. For practical reasons it depends on the number of logical nodes. The name of a logical device should contain only characters 'a'-'z', 'A'-'Z', '0'-'9', '_'. Its length concatenated with the IED's name cannot exceed 64 characters.

It is possible to create new logical device by dragging a logical node onto the IED name node. Another option to create new LD is right-clicking on the logical node – selecting copy – right clicking on the IED name – selecting Create new logical device. Moving logical devices is not allowed.

The default logical nodes of a logical device are LN0, LPHD1 and the copied logical node. The property editor of a selected logical device contains the name and a description field. Please note that the text placed in the description field will be transferred to the SCL file's (ICD or CID) corresponding field. It is also true for logical node and dataset objects.

Deleting logical device is only possible for logical devices which contain only LN0 and LPHD1 logical nodes.

There is a check-box in front of the logical node name. The red cross means the function connected to the logical node is inactive in the configuration.

Logical Node LN0

The communication configuration objects have to be placed in the LN0 logical node inside the logical devices. These objects are datasets, report control blocks and GOOSE control blocks. They must be placed to this logical node. The maximum number of the objects is determined by the device type and can be found in the communication configurator. By clicking on the IED name, the properties window will appear on the right side showing the object limits.

Using the tree

The left panel displays the data model. Object names can be changed (if it is enabled for the object type) by clicking on it in the tree or using the property editor on the right side. Since some parameters are not allowed to change, the editor denies the selection of them. Editable parameters are checked against their constraints as the user leaves the field.

IEC 61850 Logical Node prefix can be 6 characters long; prefix + instance cannot exceed 7 characters.

In this dialog, the factory default prefix and the instance number can be modified. It is also possible to edit the description attribute of the logical node. In the same time, the free text entered here is mapped to the attribute of the "NamPlt" data object of the edited LN.

NOTE: These elements must not be modified after system integration (importing an SCD file) because such an action would change the Logical Node references.



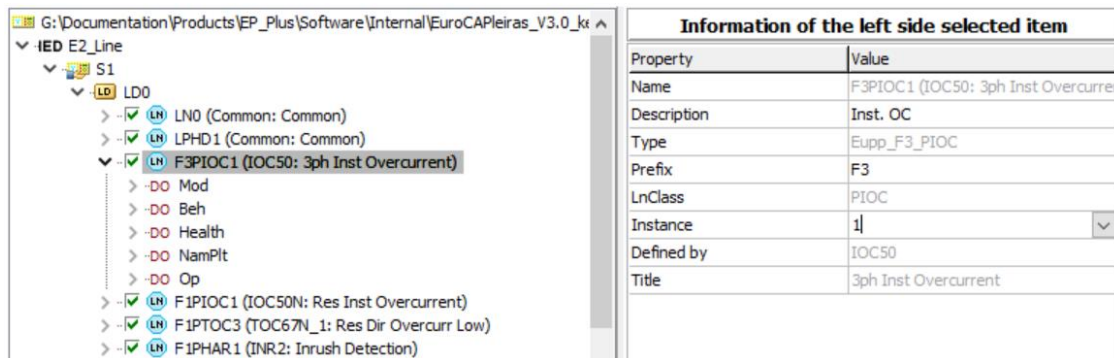

Figure 0-4 Logical Node property

Creating, moving and deleting objects can be done in two ways: using context menu or using drag and drop operation.

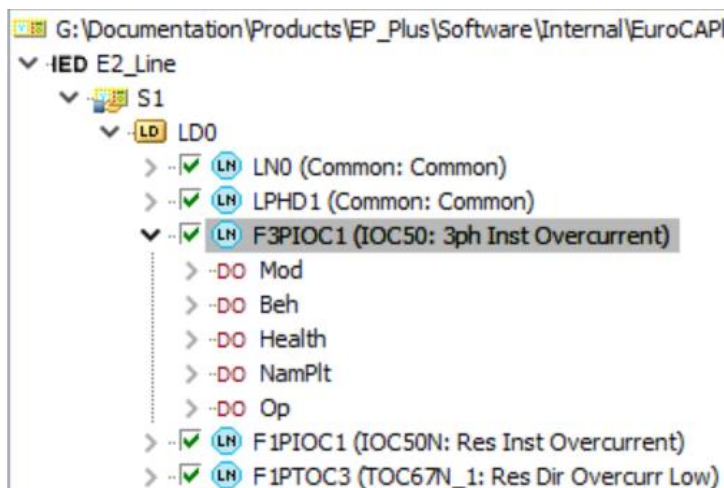

Figure 0-5 IEC 61850 data model in the tree view

Creating new objects using context menu of the tree:

- click with the right button of the mouse on the object you want to be contained by the new object and select **Copy**. Pressing Ctrl-C buttons while the object is selected has the same effect.
- right click on the target and select **Create new ...** (Ctrl-A)

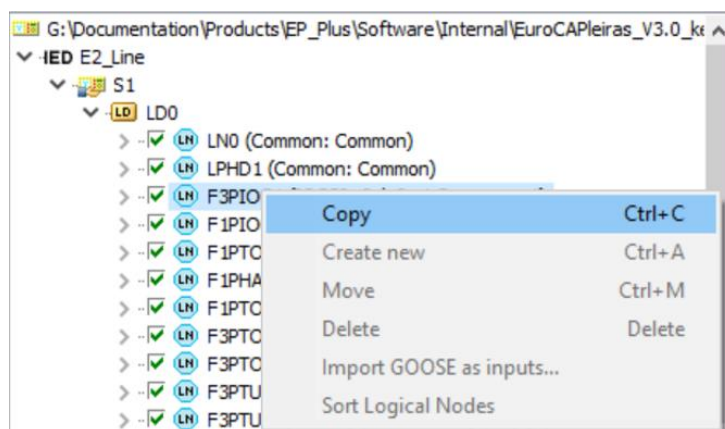

Figure 0-6 Creating object by context menu, copy first...

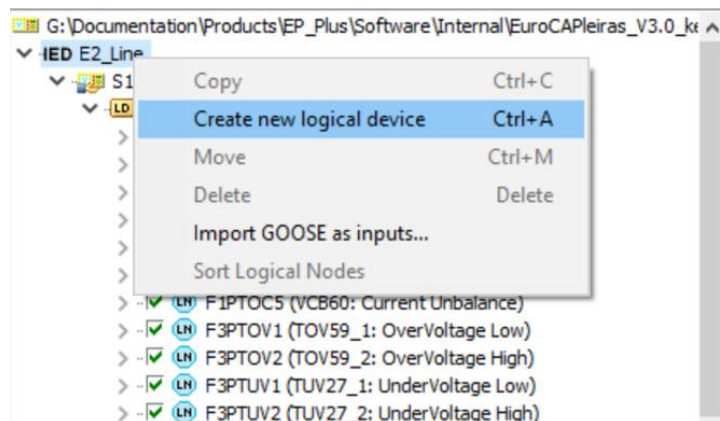

Figure 0-7... then paste it to the target object

Creating new objects using the drag and drop method (use only with objects displayed within one page – there is no scrolling function): click and hold left mouse button on the object you want to be contained by the new object, drag it onto the target object and release mouse button. The new object will be created with a default name. The focus will jump onto this new name allowing the user to give the desired name immediately.

Create operation is allowed for logical devices under the IED, datasets, report control blocks and GOOSE control blocks under the LN0 logical node.

Moving objects is similar to creating. The only difference is that the target object is an existing object which can serve as a container for source object. While dragging an object, the symbol of the dragged object shows that the selected target can be a container of the target or can't be. Movable objects e.g. logical nodes, report and GOOSE control blocks.

Datasets

Datasets are the basic objects for the reporting and GOOSE services. New dataset can be created in the usual way: with context menu or with drag and drop operation. Source object can be a single data object or data object attribute selected from any logical node.

Target object must be a LN0 type logical node. Please don't forget to give new name to the new dataset, immediately after creating it.

The new dataset will have only one item, the source data object. To add new data objects to the dataset use the context menu or the drag and drop method. On the right panel there is a dataset editor (items list) which always shows the last selected dataset items. The list area can also be used as the target for the drag and drop operation. Multiple data objects can be selected for dragging into a Dataset.

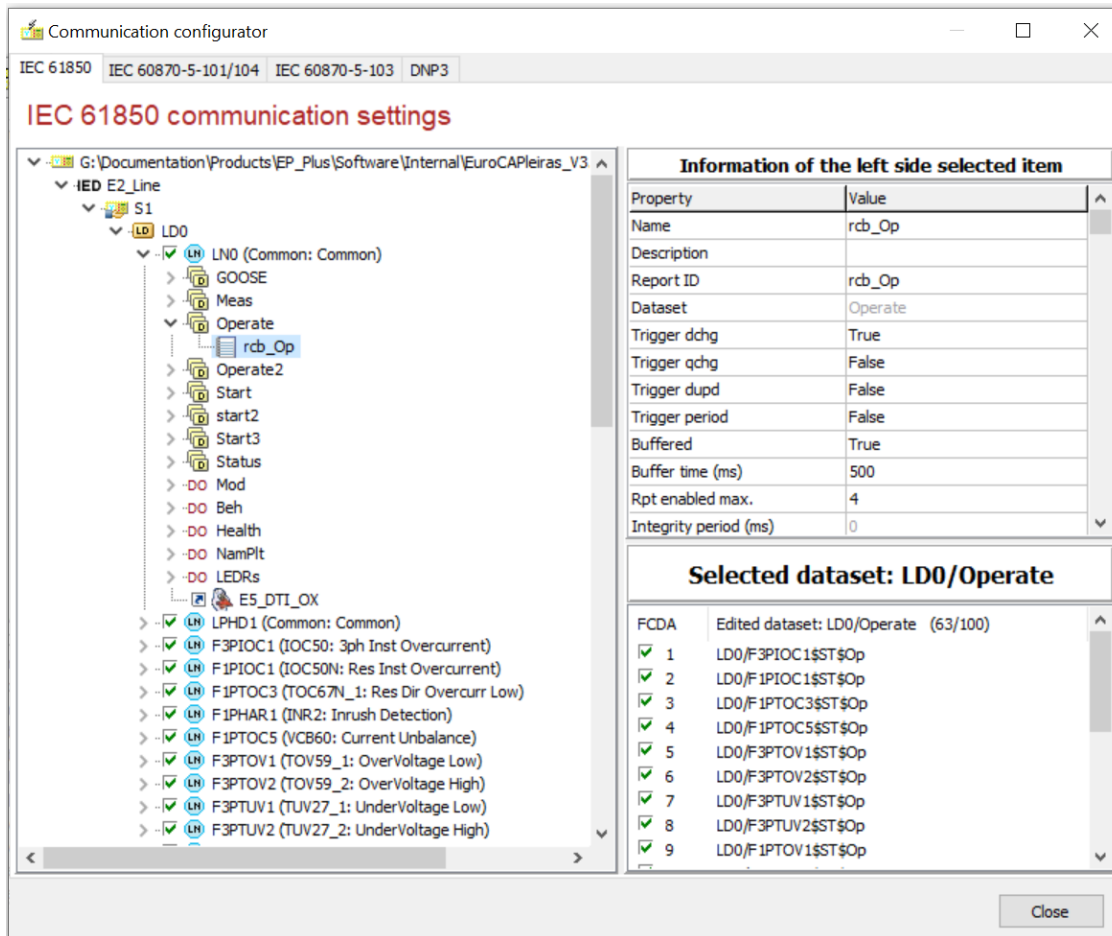

Figure 0-8 Dataset items list box

The configuration revision number of the affected Control Block is automatically increased when a function block is added, removed, activated or deactivated and when a Logical Node's ownership is changed. The increase is executed when the Code and parameter files have been generated (build process of the configuration file).



NOTE: there are two types of datasets, the data object level makes the difference. A data object can be referenced by its data object name. In this case, protocol algorithms assume all the referenced data object's attribute exist in the dataset. E.g. a dataset which contains an item given by the "IEDName/LD1.INTCILO1.EnaOpn" reference contains **stVal**, **q**, **t**, **dU** data object attributes also. This data structure comes from the **EnaOpn** object's well known common data class (CDC) SPS(Single Point Status). This type of dataset can be used for buffered or unbuffered reporting service.

The other type dataset may contain a list of the data object attributes, there should be three items for the same example:

- **IEDName/LD1.INTCILO1.EnaOpn.stVal**,
- **IEDName/LD1.INTCILO1.EnaOpn.q**
- **IEDName/LD1.INTCILO1.EnaOpn.t**.

This type of dataset can be used for buffered or unbuffered reporting and also for GOOSE service. For GOOSE service, timestamp is not used.

A data object can be member for more dataset. However, it is not recommended to create a dataset which contains the same object more than once.

Deleting selected dataset items is possible by pressing **Del** button on the keyboard. Multi selection is also possible. Before it is deleted, the user has to answer the following question in a new window: "Do you really want to delete the selected FCDA(s)?"

Deleting the dataset is possible only when it is not attached to any report control block. There is a check-box in front of the logical node name. The red cross means the function connected to the logical node of data object is inactive in the configuration.

Now you can create a Dataset in the following ways:

- from the local menu of LN0 (right click on LN0)
- by dragging a DO from a logical node to LN0

You can move a DO from one dataset to another (to avoid exceeding limits).

Order of Logical nodes in the communication configurator window shows the order of the function blocks were added into the configuration.

Logical nodes can be sorted by name (except for LN0 and LPHD1) in the local menu of LD0.

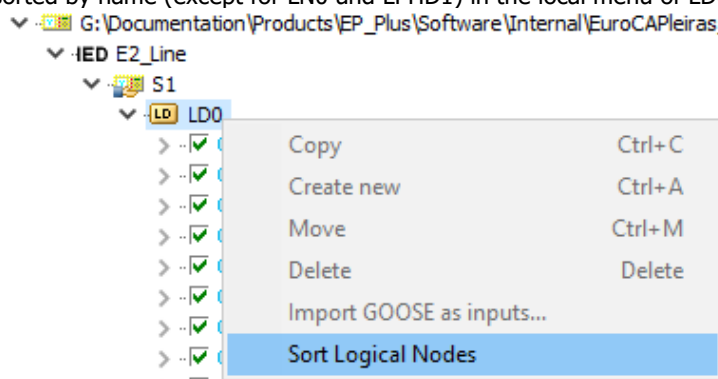

Figure 0-9 Context menu of LD0

Communication configurator has to close and reopen to get the original order of Logical nodes.

Reporting

Information collected by bay-level devices should be transferred to the control center. The IEC 61850 standard defines reporting service for this purpose. Doing it in proper way there must be report control blocks defined.

Report control block can be created for the LN0 logical node inside any logical device. To create a new report control block, drag the desired dataset onto the LN0 logical node or use the context menu of Dataset.

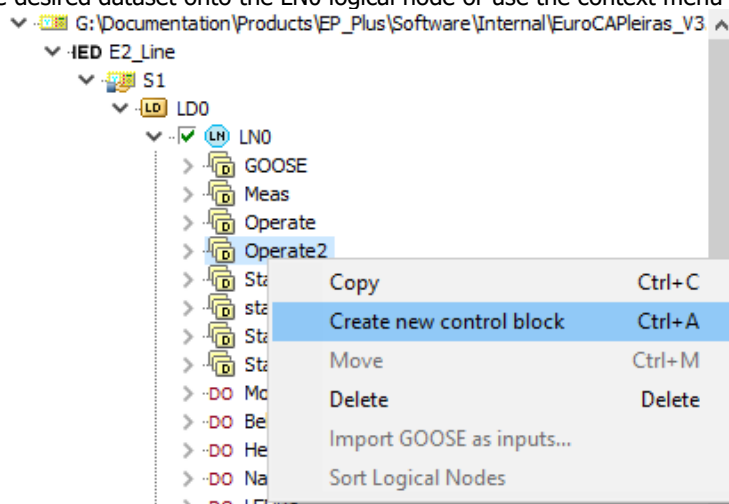

Figure 0-10 Context menu of Dataset

A dialog will pop up asking confirmation to the create operation.

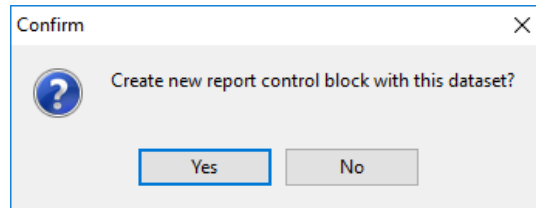

Figure 0-11 Confirmation dialog box of creating report control

Source dataset can be defined at FCD or FCDA level. (in the last case, the program offers creating a GOOSE control block, see next chapter 0). It is recommended to give a user-defined name just after the creation.

The property editor allows the user to change the parameters of the selected control block, see Figure 0-8.

In the object tree, the report control blocks are below their linked datasets.

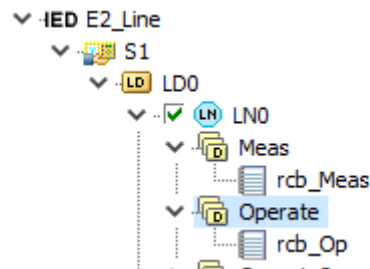

Figure 0-12 Object tree - the RCBs are below their linked datasets

GOOSE communication

GOOSE communication means data exchange among any IEC 61850-conform devices. GOOSE messages are controlled by GOOSE control blocks. Creating new GOOSE control block is very similar to the report control's case. The only significant difference is that the dataset has to be defined at FCDA-level for all their items.

The owner of the IN8GGIO1 LN is Go8 GOOSE publisher function block. This is used to create GOOSE signals from the connected inputs to "stVal" in the logic editor.

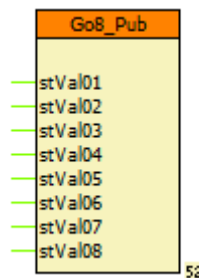

Figure 0-13 GOOSE publisher function

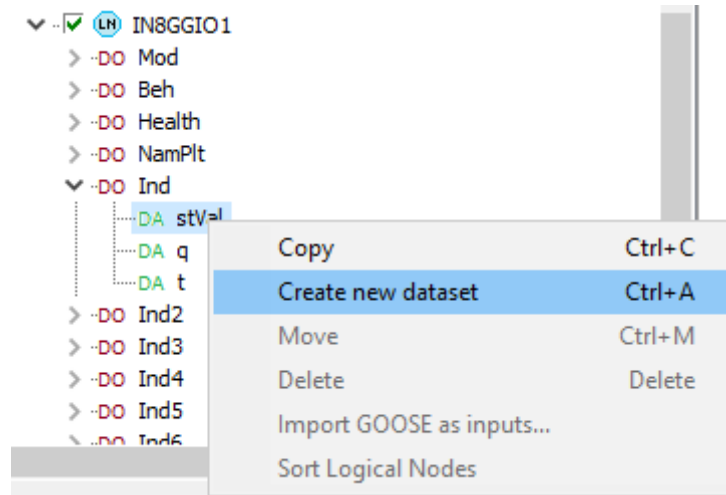

Figure 0-14 Creating Dataset from the local menu

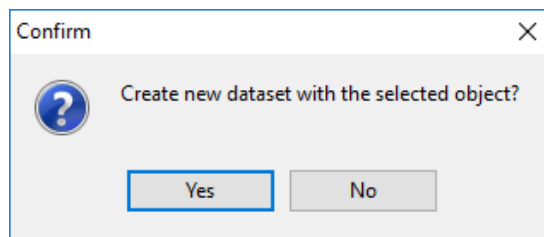

Figure 0-15 Confirmation question of creating Dataset

The program offers creating a Report control block at first, don't accept it, then you can create a GOOSE control block with the selected Dataset. The parameters of the selected GOOSE control block can be modified in its property editor panel. It is recommended to give a user-defined name just after the creation.

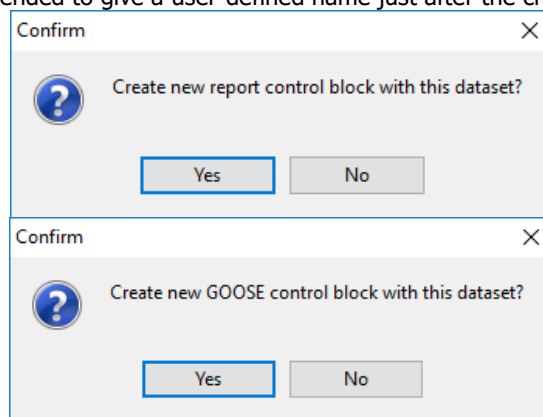

Figure 0-16 Confirmation questions of creating GOOSE control block

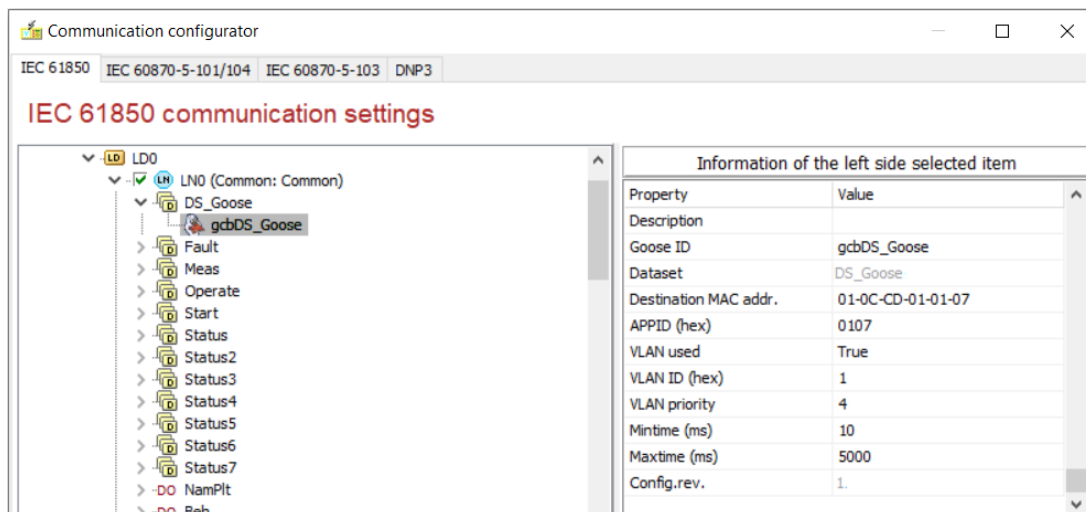

Figure 0-17 Property of GOOSE control block

GOOSE input mapping

Receiving GOOSE messages is possible using external references given in the input section of the SCD file. This file is the result of system integration task and may be imported by EuroCAP software. To import it, go to the main screen, then select File / Import / IED Description. User will be asked to select the own IED name by a list dialog window. It is important that the selected device must be identical with the currently opened IED. The available input data will be shown below the LNO logical node of the logical device.

There is an alternative way to import any GOOSE data without using system integration software. The EuroCAP will take all the available published GOOSE data from any CID file. Open the context menu of the IED name, then select „Import GOOSE as inputs...“. User should select the desired publisher IED from the list.

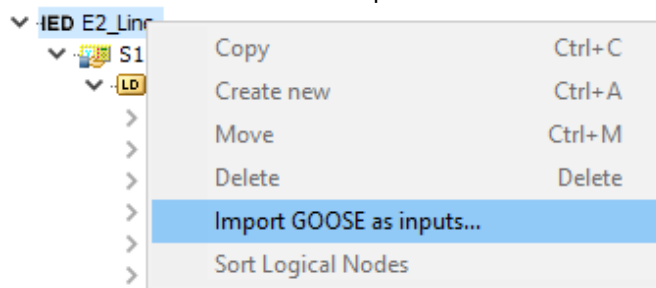

Figure 0-18 Import GOOSE from any CID file

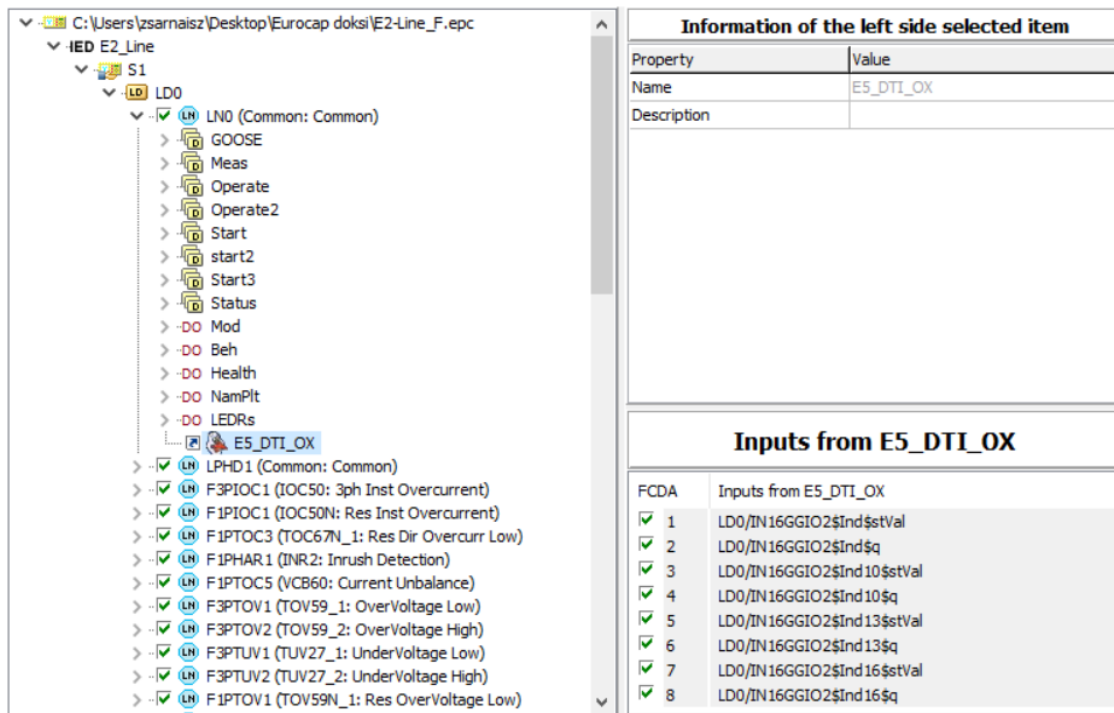

Figure 0-19 Imported GOOSE signals from a .CID file

The "Subscribed GOOSE assignment" menu lists the input references subscribed by the IED. GOOSE subscription can be configured by means of the SCD file, i.e., the list of external references appears only after a valid SCD file is imported.

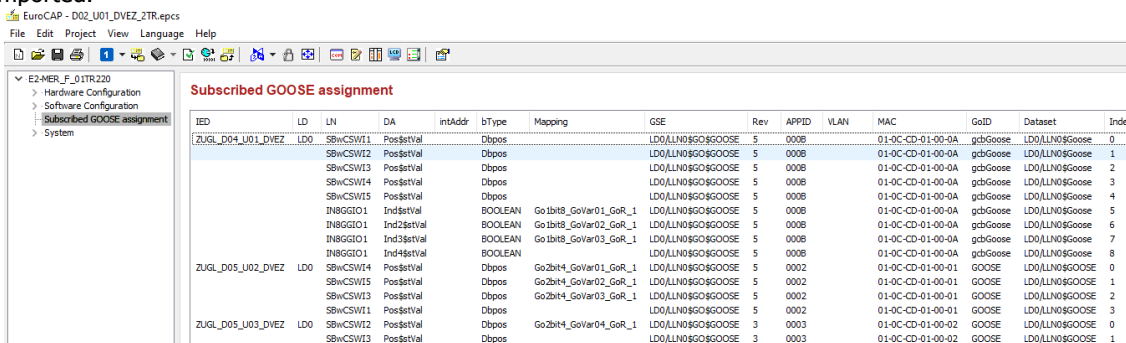

Figure 0-20 External GOOSE references

When double clicked on the selected row (DA of the GOOSE publisher IED), the property dialog of the selected external reference appears, and the user can map the subscribed input to one of the predefined Goose receiver channels. Alternatively, this can be done by clicking on the "Modify" button on the bottom of the window.

Figure 0-21 External GOOSE reference properties

There are two types of predefined receiver channels: a 2-bit type typically for switchgear statuses and a 1-bit type typically for protection signals. Please note that Europrot+ devices accept only data attributes as external reference. Data objects cannot be subscribed by the tool. External references containing a "q" attribute are automatically mapped to the same receiver channel as the status value of the corresponding data object. Receiver channels are grouped into function blocks. Currently two function block types are available: one with eight 1-bit channels and one with four 2-bit channels.

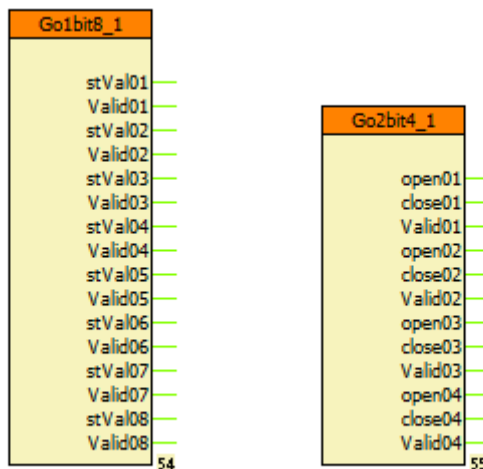

Figure 0-22 Receiver channel function blocks

All channels have a Validity output, which is logical TRUE if the IED receives the mapped GOOSE messages within the maximum time period; otherwise, it goes to FALSE. The validity output of one channel also goes to FALSE if the q data attribute is mapped to this channel as well and its validity bits are not 00. The output variables of these function blocks are available both in the graphical Logic editor and in the Sync close Contacts menu.

IEC 60870-5-101 / 104

Legacy communication protocols IEC61870-5-101 and 104 (in short form IEC101 and IEC104) have common configuration sheet since their application level is the same. The tree of the configuration software has sub-nodes of the differentiated base data types. The tree menu is fixed, user specific data can be added below the sub-nodes. By selecting the root of the tree, the basic IEC101/IEC104 parameters appear. By default, structured addressing is used, it means bit masking to differentiate data types.

Length of link address, CAD and COT can be 1 or 2 byte(s). IOA can be 1, 2 or 3 byte(s). Default setting is shown on Figure 0-23 .

Select-execute timeout has to be 0 for direct execution and between 5 to 255 for SBO command.

Period of bg. scan 0 means that background scan is not used. Minimum value is 5s and the maximum is 255 when it is used.

Base addresses of the different object types can be modified in decimal numbers which are black numbers. Hexadecimal addresses change automatically (grey numbers).

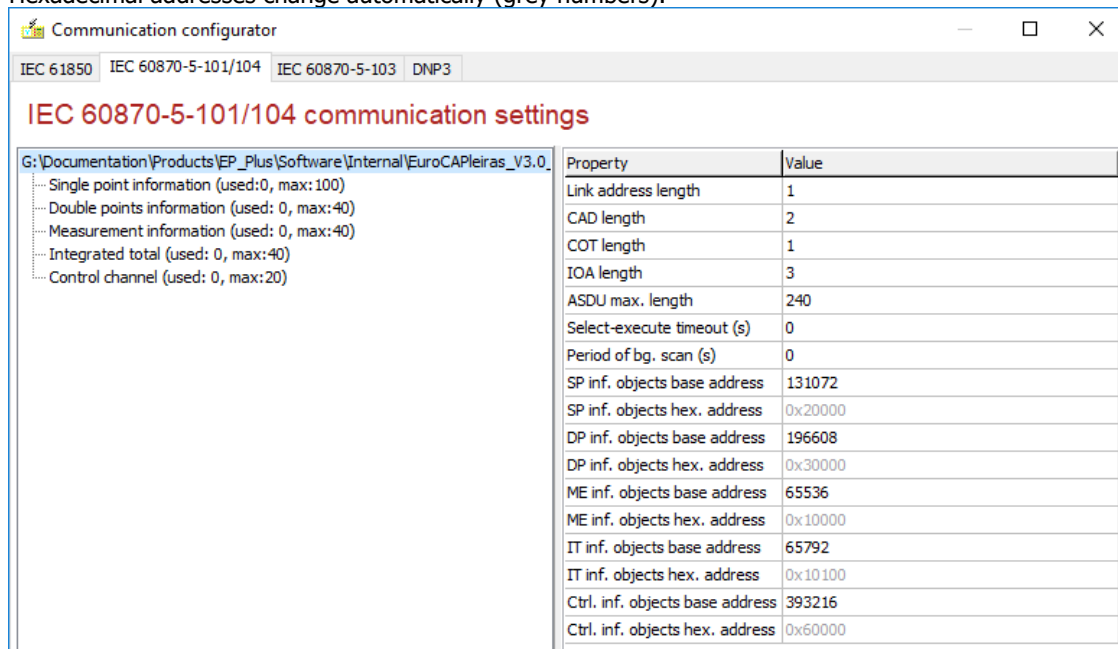

Figure 0-23 Basic parameters of IEC101/IEC104

The context menu of different data types provides the following operations:

- New Object [Insert] – the user can select the object to be inserted from a list which contains all objects from the proper type. So far, the first object from this list is automatically inserted. An object is disappearing from the list of source events when it is added to the list of reported objects.
- Add All – adds all available items for the selected data type with a single click
- Sort by Address – objects below the selected node will be sorted by their address
- Readdressing Objects – removes existing addresses and creates new ones for all object (sorted)

Property editor of a selected object displays the parameters. Some of them are allowed to be changed, others are read-only. It is configurable for every signal to take part in the General Interrogation or Background scan cyclically sending. Rising or falling edge trigger event types can be defined for spontaneous data sending. The owner Function Block of the referred object is displayed as a prefix before the name of the object.

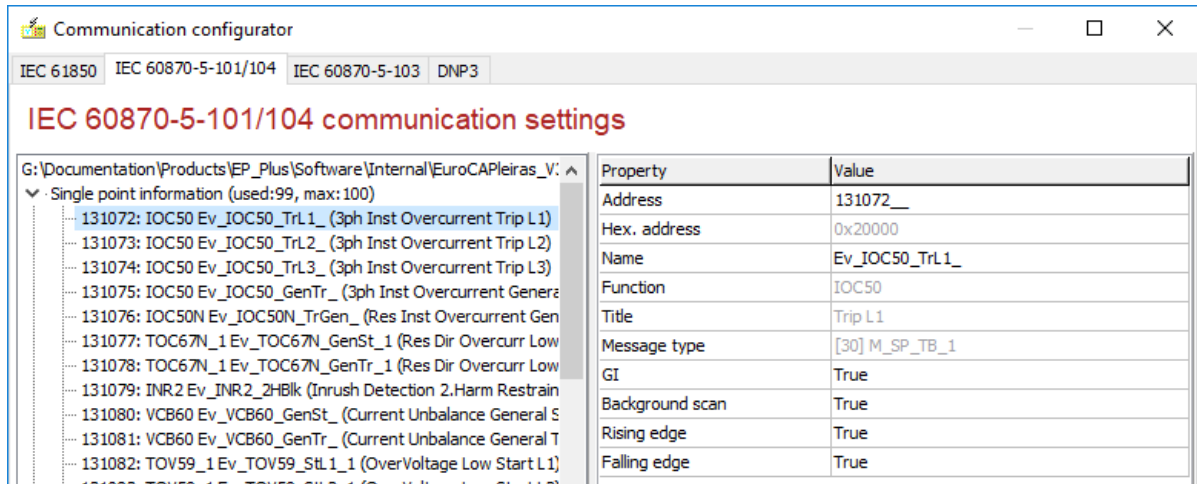

Figure 0-24 Properties of a signal

It is possible to delete selected objects by pressing **Del** button. Multi selection is also possible. Using multi selection with CTRL button hold down is possible and allows changing the same type of parameters of the selected items.

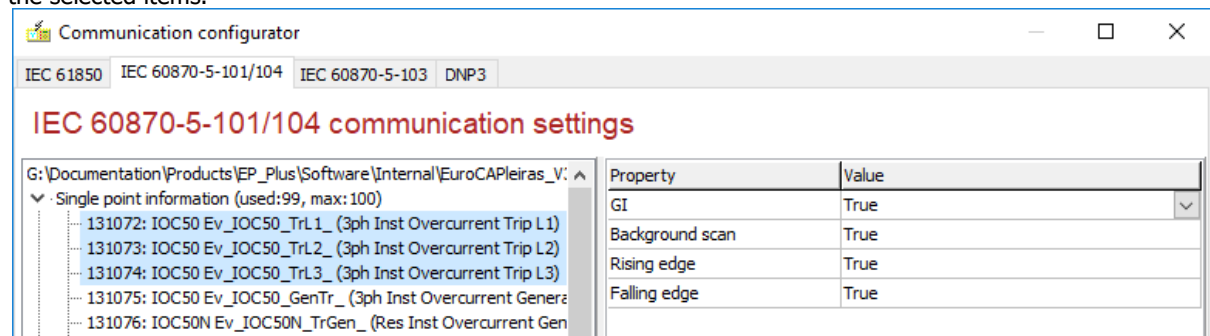

Figure 0-25 Multi selection allows to change the same type of objects

Control type of the command is selectable. Supported types are 45,46,47,58,59,60.

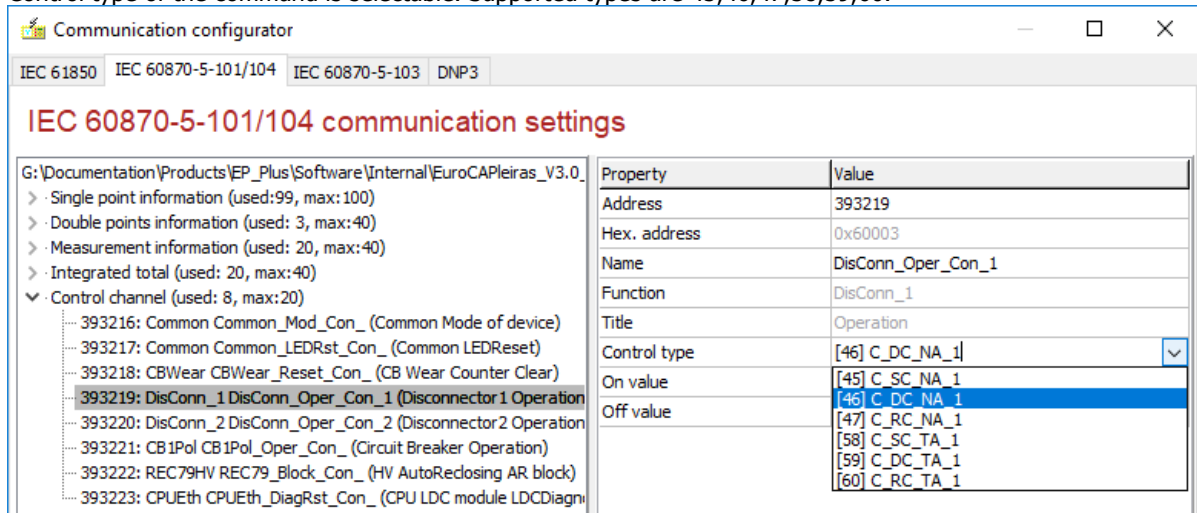

Figure 0-26 Properties of a command

Supported ASDUs are written in the IEC 101-104-103 interoperability list.pdf which is available on Protecta web page.

IEC 60870-5-103

The IEC 60870-5-103 communication protocol has been designed for single-function protection devices. It is implemented in the EuroProt+ device and needs application engineering. The sheet labelled with the protocol name contains a fixed tree object.

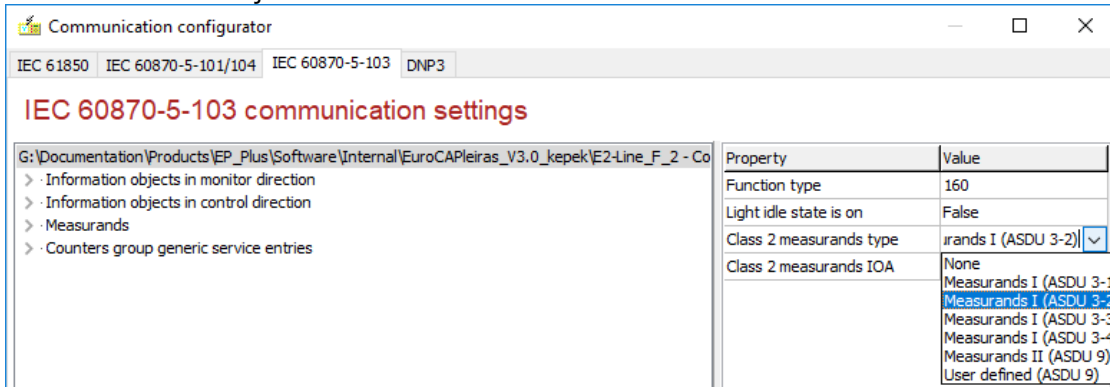

Figure 0-27 Fixed tree of IEC103

Since the protocol specifies fixed address for the commonly used functions, sub-nodes list these addresses prepared. User should assign the data objects to the corresponding address. By clicking on any address, the property editor opened on the right side allows the user to select the desired data object. The **Source** field is a combo-box with the available data objects. Addresses from 164 to 239 is a free range, it can be used for any binary data object of any function selected from the device's database. To delete a data object from the **Source** field, double-click on it or select the empty row at the beginning of the list. The **GI** parameter true means that data should be included in the general interrogation. It is allowed to change in case of the free addresses. In the standard range it is fixed.

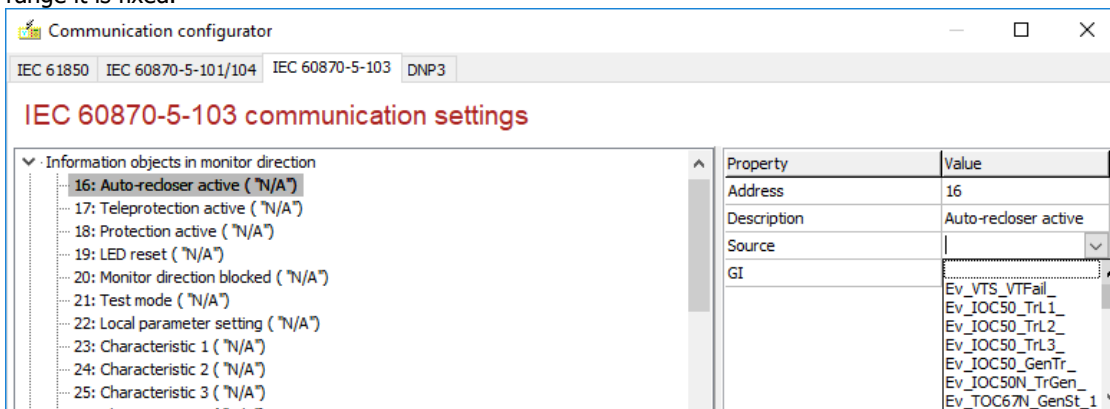

Figure 0-28 Selection of standard data item of IEC103 protocol

According to the standard, measurements are specified as class 2 messages. The assignment of the standard frame items should be defined by the user. The protocol's root node contains a parameter called **Measurands** which is used for selecting the class 2 message type. User can choose either the standard message format or can define user-specific message. Standard formats are the different variations of the **Measurands I** (ASDU type 3) and can be the **Measurands II** format (ASDU type 9). The items of sub-node **Measurands** depend on the selected frame type. It is the user's responsibility to select the right data object for the right data item of the class 2 message to keep the system conformity to the standard. For not assigned items the communication software of the device will transmit zero with invalid flag (ER=true).

By selecting the **User-defined** value of the **Measurands** parameter, user is allowed to build non-standard message. It will be transmitted with ASDU 9 type frame without gaps (no empty item enabled). Protocol software transmits only one type of class 2 message selected as described. Any measurands has its own source data object parameter in the property editor. In addition, it is possible to define the scaling factor here. Standard values are the nominal value of the specific data multiplied by 1.2 or 2.4. User can define non-standard value also. Please note that the measurement objects in the device are represented as floating point analogue values in base SI units (e.g. volts, amperes, etc.)

The EuroProt+ device is a native IEC 61850 device. As a consequence, all process calculating measurements as floating point objects and there is no prefixes used. It ensures more accuracy in the data communication and

eliminates the using of scales. These values are available via generic services of the IEC103 standard. Data object description can be found below the **Measurands group generic service entries** and **Counters group generic service entries**. For more information please read the standard.

- A source object cannot be assigned to multiple IEC 103 measurands II and/or control items.

DNP3

The standard DNP3 communication has its own definition sheet. Sub-nodes include the supported DNP3 object types. Detailed list of supported frames and object types can be found in the "EP+ DNP3 Device Profile" document on Protecta web page.

By selecting the root of the tree, the basic DNP3 parameters appear, see Figure 0-29. Data link message length can be set between 50 and 292 octets. Data link confirmation can be activated (true) or deactivated (false). Application layer message length varies between 100 and 2048 octets. Application confirmation timeout and SBO timeout have a setting range from 3 to 60 seconds.

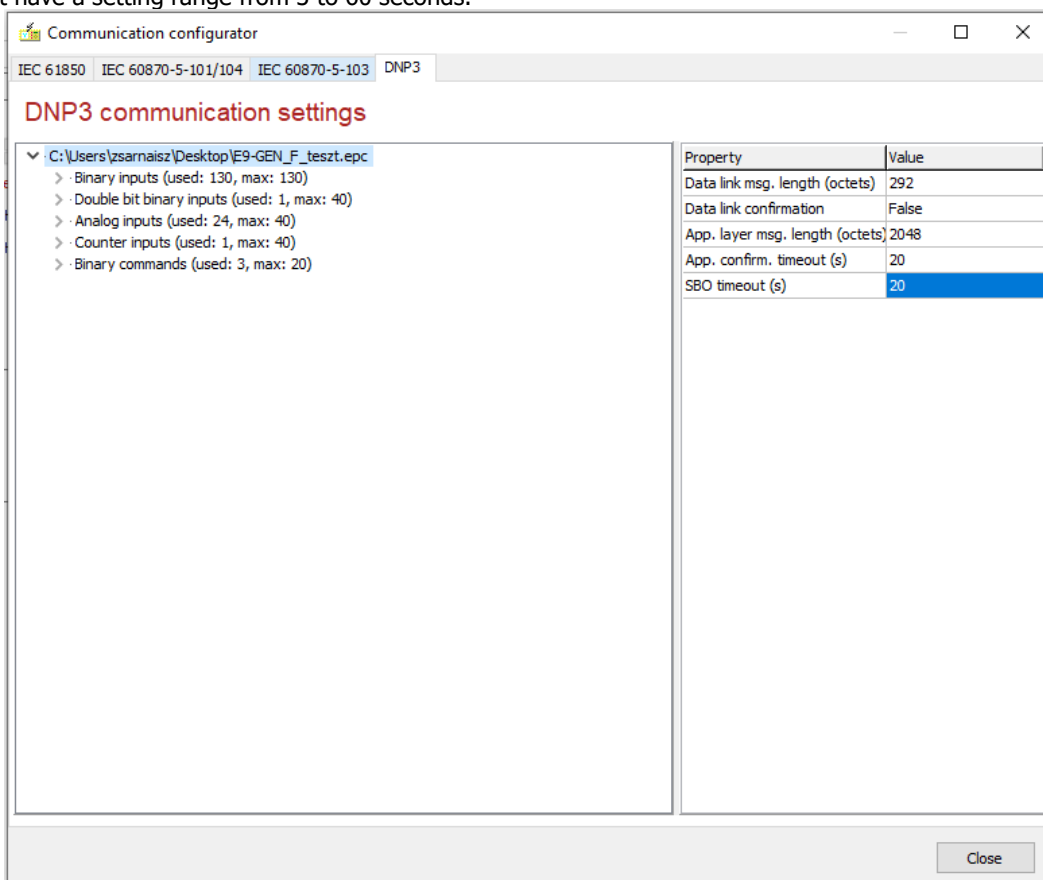

Figure 0-29 Basic parameters of DNP3

Context menu of a sub-node contains two commands:

- **New object** adds a single data to the node. The data source property will be automatically assigned to the next available object. Index will be the last used index value plus one.
- **Add all** command adds all available objects to the selected tree node.

The DNP3 protocol uses indices instead of addresses. The EuroProt+ device doesn't allow gaps. By clicking with right mouse button on a single data item the context menu allows the following operations:

- **Delete** will delete the selected object and make a trigger for an automatic index-rearrangement to ensure gap-free indices.
- **Move Object...** is an index manipulation command with sub-commands. Selected item can be moved in the indexed list.

Property editor allows the user to change the source of the selected data object. The listed data points are in a filtered list. This way user can select compatible data object only. Index cannot be changed directly in the property editor; it can be changed by moving the data item.

DNP3 protocol defines a kind of classification parameter. This parameter is also available in the property editor. The allowed range is 0..3, and empty value also enabled. Multi selection for class changing is also possible.

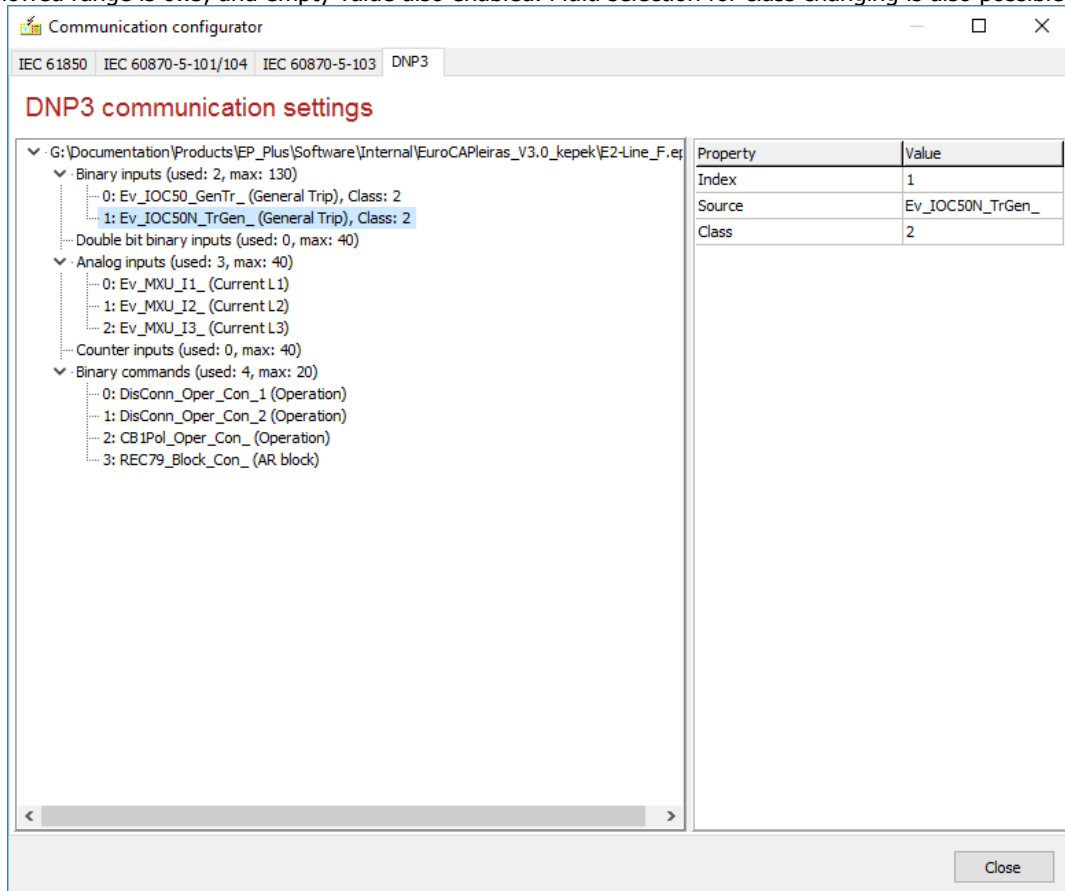

Figure 0-30 DNP3 setting sheet